



**U.S. Department of the Interior
U.S. Geological Survey**

**RESULTS OF THE U.S. GEOLOGICAL SURVEY'S ANALYTICAL
EVALUATION PROGRAM FOR STANDARD REFERENCE SAMPLES
DISTRIBUTED IN OCTOBER 2000**

Open-File Report 01-137

**Results of the U.S. Geological Survey's Analytical
Evaluation Program for Standard Reference Samples
Distributed in October 2000**

By Brooke F. Connor, Jonathan P. Currier, and Mark T. Woodworth

U.S. GEOLOGICAL SURVEY

Open-File Report 01-137

**Lakewood, Colorado
2001**

DEPARTMENT OF THE INTERIOR

Gayle A. Norton, Secretary

U.S. GEOLOGICAL SURVEY

Charles G. Groat, Director

For additional information
write to:

Chief, Branch of Quality Systems
U.S. Geological Survey
Water Resources Division
Box 25046, Mail Stop 401
Denver Federal Center
Denver, Colorado 80225-0046

Copies of this report can be
purchased from:

U.S. Geological Survey
Branch of Information Services
DFC, Bldg. 810, Box 25286
Denver, Colorado 80225-0286
888-ASK-USGS

CONTENTS

	Page
Definition of analytical methods, abbreviations, and symbols.....	iv
Abstract.....	1
Introduction.....	1
Preparation of standard reference samples.....	6
Laboratory analyses.....	7
Laboratory performance ratings.....	10
Statistical presentation of data.....	10
Reference.....	11

FIGURE

Figure 1. Statistical parameters shown on reported-data graphs in tables 11-16.....	11
-------------------------------------------------------------------------------------	----

TABLES

1. Laboratory participants in the analyses of standard reference samples distributed in October 2000.....	3
2. Middle East laboratory participants in the analyses of standard reference samples distributed in October 2000.....	5
3. Analytes determined in standard reference samples distributed in October 2000.....	8
4. Overall laboratory performance ratings for standard reference samples distributed in October 2000	12
5. Laboratory performance ratings for standard reference sample T-163 (trace constituents)	15
6. Laboratory performance ratings for standard reference samples M-156 (major constituents)	27
7. Laboratory performance ratings for standard reference sample N-67 (nutrient constituents)	34
8. Laboratory performance ratings for standard reference sample N-68 (nutrient constituents)	36
9. Laboratory performance ratings for standard reference sample P-35 (low ionic strength constituents).....	38
10. Laboratory performance ratings for standard reference sample Hg-31 (mercury).....	41
11. Statistical summary of reported data for standard reference sample T-163 (trace constituents).....	42
12. Statistical summary of reported data for standard reference sample M-156 (major constituents).....	70
13. Statistical summary of reported data for standard reference sample N-67 (nutrient constituents).....	86
14. Statistical summary of reported data for standard reference sample N-68 (nutrient constituents).....	91
15. Statistical summary of reported data for standard reference sample P-35 (low ionic strength constituents).....	96
16. Statistical summary of reported data for standard reference sample Hg-31 (mercury)	107
17. Most probable values for constituents and properties in standard reference samples distributed in Oct. 2000.....	108
18. Percent acceptable and unacceptable analyses by analyte.....	110

RESULTS OF THE U.S. GEOLOGICAL SURVEY'S ANALYTICAL EVALUATION PROGRAM FOR STANDARD REFERENCE SAMPLES DISTRIBUTED IN OCTOBER 2000

By Brooke F. Connor, Jonathan P. Currier and Mark T. Woodworth

ABSTRACT

This report presents the results of the U.S. Geological Survey's analytical evaluation program for six standard reference samples -- T-163 (trace constituents), M-156 (major constituents), N-67 (nutrient constituents), N-68 (nutrient constituents), P-35 (low ionic strength constituents), and Hg-31 (mercury) -- that were distributed in October 2000 to 126 laboratories enrolled in the U.S. Geological Survey sponsored interlaboratory testing program. Analytical data that were received from 122 of the laboratories were evaluated with respect to overall laboratory performance and relative laboratory performance for each analyte in the six reference samples. Results of these evaluations are presented in tabular form. Also presented are tables and graphs summarizing the analytical data provided by each laboratory for each analyte in the six standard reference samples. The most probable value for each analyte was determined using nonparametric statistics.

INTRODUCTION

The U.S. Geological Survey (USGS) conducts an interlaboratory analytical evaluation program semiannually. This program provides a variety of standard reference samples (SRSs) to accomplish quality assurance testing of laboratories and to provide an adequate supply of samples that contribute to quality control programs of participating laboratories. Natural-matrix reference materials are preferred for use in this interlaboratory evaluation program. A series of samples are prepared and distributed each spring and fall. The program began in 1962 with a single sample containing major constituents that was prepared from distilled water and reagent-grade chemicals. Twenty-three USGS laboratories participated in the first analytical evaluation program. Since that time, objectives of the program have been to:

- (1) evaluate and improve the performance of USGS and other participating laboratories;
- (2) provide a library of carefully prepared, homogeneous, stable reference materials for use in the quality control programs of laboratories;
- (3) identify analytical problem areas;
- (4) identify quality assurance needs with respect to environmental analyses and develop new reference materials to meet these needs; and
- (5) evaluate the accuracy and precision of analytical methods.

A total of 266 USGS and non-USGS laboratories are enrolled in the program, which can currently provide 9 different types of SRSs:

1. Trace constituents.
2. Major constituents.
3. Nutrient constituents.
4. Low ionic-strength constituents.
5. Mercury.
6. Whole water (water with suspended sediment).
7. Acid mine water constituents.
8. Ground-water trace constituents.
9. Ground-water major constituents.

Though this is not a laboratory certification program, participation in this continuing quality assurance program is mandatory for all laboratories providing water-quality data for USGS sponsored reports or storage in the USGS national databases. The results from this study can be used to alert participating laboratories of possible deficiencies in their analytical operations and provide reference materials for laboratory quality-control programs. Participating laboratories are identified only by a confidential laboratory code number.

A library of SRSs from previous evaluations, is available. USGS offices and participating laboratories can purchase these SRSs for further testing, continuing quality assurance, and quality-control programs on-line (<http://bqs.usgs.gov/srs>) or by contacting:

U.S. Geological Survey
Branch of Quality Systems
SRS Purchasing
Denver Federal Center, Bldg. 53
P. O. Box 25046 MS 401
Denver, Colorado 80225-0046
(303) 236-1871

This report summarizes the analytical results submitted by 122 laboratories that requested and were shipped SRSs for the October 2000 evaluation (table 1). Not all SRSs are requested or necessarily analyzed by all the laboratories; nor do all laboratories enrolled in the program participate in each evaluation. Analytical results for the following are presented in this report:

T-163	Trace constituents	N-68	Nutrient constituents
M-156	Major constituents	P-35	Low ionic strength constituents
N-67	Nutrient constituents	Hg-31	Mercury

Laboratories that are providing analytical services to USGS offices are requested to analyze the appropriate SRSs for the same analytes requested by the USGS offices. All laboratories are requested to include the analytical methods used to determine the concentration of each analyte. When analytical method information was provided, it has been included in tables 11 – 16.

Table 1. *Laboratory participants in the analyses of standard reference samples distributed in October 2000*

State	City	Participating Laboratory
Alabama	Tuscaloosa	Geological Survey of Alabama
Alaska	Soldotna	Alaska Department of Fish and Game
Arkansas	Arkadelphia	Ouachita Baptist University
	Fayetteville	University of Arkansas Water Quality Laboratory
California	Davis	University of California, Davis, Division of Environmental Studies
	La Verne	Metropolitan Water District
	Martinez	Central Contra Costa Sanitary District
	Menlo Park	U.S. Geological Survey
	San Diego	U.S. Geological Survey – Water Resources Division
	Santa Fe Springs	West Coast Analytical Services
	Tahoe City	Tahoe Research Group - High Sierra Water Laboratory
	West Sacramento	California Department of Water Resources
Colorado	Alamosa	U.S. Bureau of Reclamation Closed Basin Division
	Arvada	Severn Trent Laboratories Denver
	Boulder	U.S. Geological Survey Surface Water Chemistry Research
	Colorado Springs	Colorado Springs Utilities, Water Resource Department
	Denver	U.S. Geological Survey, National Water Quality Laboratory
		U.S. Bureau of Reclamation - Denver Environmental Chemistry Laboratory
	Denver	
	Denver	Metro Wastewater Reclamation
	Denver	WRD Earth Science Investigation Program, Yucca Mtn. Project
	Ft. Collins	U.S. Department of Agriculture, Forest Service
	Ft. Collins	Water Quality Laboratory - City of Fort Collins
	Golden	Accu-Labs
	Grand Junction	Enviro-Chem Analytical, Inc.
	Greeley	Central Colorado Water Conservancy
	Lakewood	U.S. Geological Survey, WEBB Colorado District Office
	Northglenn	City of Northglenn Water Treatment Facility
	Pueblo	City of Pueblo Waste Water Treatment Plant
	Westminster	City of Westminster - Semper Water Quality Laboratory
Delaware	Dover	Delaware Department of Natural Resources
Florida	Brooksville	South West Florida Water Management District
	Ocala	U.S. Geological Survey, Ocala Water Quality and Research Laboratory
	Tallahassee	City of Tallahassee
	Tallahassee	Florida Department of Environmental Protection
	Tampa	Hillsborough County EPC
	West Palm Beach	South Florida Water Management District
Georgia	Athens	Soil Testing Laboratory University of Georgia
	Decatur	Dekalb County WQC Laboratory
	Tifton	U.S. Department of Agriculture – ARS SEWRL Watershed
Hawaii	Honolulu	University of Hawaii
Idaho	Boise	U.S. Bureau of Reclamation
	Boise	Boise City Water Quality Laboratory
Illinois	Champaign	Illinois Environmental Protection Agency
Iowa	Des Moines	University Hygienic Laboratory
Kansas	Lawrence	Kansas Geological Survey

Table 1. *Laboratory participants in the analyses of standard reference samples distributed in October 2000 – Continued*

State	City	Participating Laboratory
	Wichita	City of Wichita
Kentucky	Frankfort	Division of Environmental Services
	Lexington	Kentucky Geological Survey
Maine	Orono	University of Maine - Water Research Institute
Maryland	Baltimore	Maryland Department of Health and Mental Hygiene
	Cambridge	University of Maryland, Horn Point Laboratory
	Solomons	University of Maryland Chesapeake Biology Laboratory
Michigan	Detroit	Detroit Water and Sewerage Department
Minnesota	St Paul	Metropolitan Council Environmental Services
Missouri	Jefferson City	Missouri State Health Laboratory - Department of Health
Montana	Butte	Montana Bureau of Mines and Geology
	Helena	Department of Health and Environmental Sciences- DPHHS Environmental Laboratory
New Jersey	Trenton	New Jersey Department of Health
New York	Bolton Landing	Darrin Freshwater Institute
	Brewster	N.Y. DEP Brewster Laboratory
	Grahamsville	N.Y. DEP Grahamsville Laboratory
	Hauppauge	Suffolk County Water Authority Laboratory
	Hempstead	Nassau County Department of Health
	Millbrook	Institute of Ecosystem Studies
	North Babylon	EcoTest Laboratories, Inc.
	Rochester	Monroe County Environmental Health Laboratory
	Rochester	Columbia Analytical
	Shokan	N.Y. DEP Ben Nessin Laboratory
	Syracuse	Onondaga County (OCDDS)
	Syracuse	State University of New York College of Environmental Science and Forestry
		Troy
	Troy	Rensselaer Polytechnic Institute
	Valhalla	N.Y. DEP Kensico Laboratory
North Carolina	Charlotte	Mecklenburg County DEP
	Rocky Mount	City of Rocky Mount WWTP
North Dakota	Bismarck	North Dakota State Water Commission
	Bismarck	North Dakota Department of Health
	Bismarck	U.S. Bureau of Reclamation
Ohio	Cincinnati	U.S. Environmental Protection Agency, NRMRL Treatment Technology
	Cincinnati	U.S. Environmental Protection Agency, WSWRD NERL
	Cuyahoga Heights	Northeast Ohio Regional Sewer District
	Marion	Aquatech Laboratory (ATEL)
Oregon	Corvallis	U.S. Department of Agriculture, Forest Service – CCAL
	Hillsboro	Unified Sewerage Agency
	Portland	Department of Environmental Quality
Pennsylvania	Harrisburg	Pennsylvania Department of Environmental Protection
South Carolina	Charleston	College of Charleston, Department of Geology

Table 1. *Laboratory participants in the analyses of standard reference samples distributed in October 2000 -- Continued*

State	City	Participating Laboratory
South Dakota	Brookings	South Dakota State University, Northern Great Plains Water Research
	Brookings	South Dakota State University, Water Quality Laboratory, WRI
Tennessee	Chattanooga	TVA Environmental Chemistry
Texas	Arlington	Armstrong Forensic Laboratory
	Austin	Lower Colorado River Authority Environmental Laboratory
	College Station	Texas A & M University
	College Station	Albion Environmental
Vermont	Waterbury	Vermont Department of Environmental Conservation
Virginia	Chesapeake	City of Chesapeake
	Manassas	Occoquan Watershed
	Norfolk	Old Dominion University
	Richmond	Division of Consolidated Laboratory Services
Washington	Richland	Battelle Pacific N.W. Laboratory
Wisconsin	Madison	Wisconsin State Laboratory of Hygiene
	Middleton	U. S. Geological Survey
	Middleton	Wisconsin WEBB Laboratory
Wyoming	Laramie	Wyoming Department of Agriculture

Table 2. *Middle East laboratory participants in the analyses of standard reference samples distributed in October 2000*

Location	Middle East Laboratories
Israel	Mekerot Water Co. Ltd. Central Laboratory
Israel	Mekerot Laboratory
Israel	Shafdan Dan Sewage Treatment Plant
Israel	Geological Survey of Israel Laboratory
Israel	Public Health Laboratory, Tel-Aviv
Israel	Public Health Laboratory, Beer Shiva
Israel	Environmental Hydrology & Microbiology
Israel	Public Health Laboratory, Haifa
Jordan	Water Authority of Jordan
Jordan	Royal Scientific Society - Environmental Research Centre
West Bank	Center for Chemical and Biological Analysis
West Bank	Ministry of Agriculture
West Bank	CEOHS/Birzeit University
West Bank	Najah University
West Bank	Water & Soil Environmental Research Unit
West Bank	Center for Environmental Health
West Bank	Palestinian Water Authority Laboratory

PREPARATION OF STANDARD REFERENCE SAMPLES

All of the SRSs used in this evaluation were prepared by USGS personnel located in Lakewood, Colorado, and were analyzed for analyte concentrations and physical property values before mailing. A library of these SRSs is maintained, and these SRSs can be purchased by participating laboratories and USGS offices for use in their quality-control programs.

Trace constituents sample T-163 was prepared using water collected from Big Thompson River near Drake, Colorado. The water was pumped through 0.45-, 0.2-, and 0.1-micrometer (μm) filters, in series, into a 1200-liter (L) polypropylene drum. The water was continuously circulated and passed through a 0.1- μm filter and ultraviolet sterilizer for 24 hours. Following this circulation, the water was acidified to pH 1.5 with nitric acid and chlorinated to 5 parts per million (ppm) free chlorine with sodium hypochlorite. The trace constituent concentrations were adjusted by adding reagent grade chemicals. The sample was circulated an additional 24 hours prior to bottling. During bottling, the sample was pumped through an ultraviolet sterilizer and a 0.1- μm filter. The polypropylene and fluorinated ethylene propylene bottles and caps used were acid leached with 0.2N HNO_3 , deionized-water rinsed, and autoclave sterilized.

Major constituents sample M-156 was prepared using water collected from the Eagle River near Edwards, Colorado. The water was pumped through 0.45- 0.2- and 0.1- μm filters, in series, into a 1200-L polypropylene drum. The water was chlorinated to 5-ppm free chlorine with sodium hypochlorite, continuously circulated, and passed through an ultraviolet sterilizer for 24 hours prior to bottling. The major constituent concentrations were adjusted by adding reagent grade chemicals. The sample was circulated an additional 24 hours prior to bottling. The sample is then allowed to settle for 48 hours. During bottling the sample was pumped through an ultraviolet sterilizer and a 0.1- μm filter. The polypropylene bottles and caps used were acid leached with 0.2N HNO_3 , deionized-water rinsed, and autoclave sterilized.

Nutrient constituents sample N-67 was prepared using deionized water. These samples were prepared the week prior to the mailing for this SRS evaluation. The water was pumped through 0.45-, 0.2-, and 0.1- μm filters, in series, into a 50-L polypropylene drum. The desired nutrient concentrations were obtained by adding reagent-grade chemicals. The sample was continuously circulated through an ultraviolet sterilizer for 24 hours prior to being bottled. The 60-milliliter (mL) glass vials used were new, amber, acid leached with 0.2N HCl , deionized-water rinsed, and autoclave sterilized.

Nutrient constituents sample N-68 was prepared using water collected from the Fall River near Idaho Springs, Colorado. These samples were prepared the week prior to the mailing for this SRS evaluation. The water was pumped through 0.45- 0.2- and 0.1- μm filters, in series, into a 200-L polypropylene drum and continuously circulated and passed through an ultraviolet sterilizer for 24 hours. The desired nutrient concentrations were obtained by adding reagent-grade chemicals. The sample was passed through a 0.1- μm filter while bottling. The 125-mL polyethylene bottles used were new, amber, acid leached with 0.2N HCl , deionized-water rinsed, and autoclave sterilized.

Low-ionic strength constituents sample P-35 was prepared in a 400-L polypropylene drum using snowmelt from Loveland Pass, Colorado. The water was pumped into the drum through 0.45- 0.2- and 0.1- μm filters in series. The desired phosphate and fluoride concentrations were

obtained by adding reagent-grade chemicals. Prior to bottling, the sample was continuously mixed for 24 hours while being circulated through a 0.1- μm filter and an ultraviolet sterilizer. During bottling the sample was pumped through an ultraviolet sterilizer and a 0.1- μm filter. The 500-mL polypropylene bottles used were acid leached with 0.2N HNO_3 , deionized-water rinsed, and autoclave sterilized.

Mercury sample Hg-31 was prepared using water collected from Chicago Creek near Idaho Springs, Colorado. The sample was prepared in a 200-L polypropylene drum. The river water was pumped into this drum through 0.45-, 0.2-, and 0.1- μm filters in series. The water was continuously circulated and passed through a 0.1- μm filter and ultraviolet sterilizer for 48 hours. Nitric acid (5-percent, by volume) and potassium dichromate (0.05-percent, by weight) were added to stabilize the sample. The desired mercury concentration was obtained by adding a mercury standard solution. Following an additional 24 hours of circulation, the sample was bottled. The 250-mL glass bottles and tetrafluoroethylene fluorocarbon resin caps used were new, acid leached, and deionized-water rinsed.

LABORATORY ANALYSES

The participating laboratories were asked to determine constituents that are summarized in table 2. The number of analytes varied from 28 in T-163 (trace constituents) to 1 in Hg-31 (mercury).

Table 3. *Analytes determined in standard reference samples distributed in October 2000*

[mg/L, milligrams per liter; µg/L, micrograms per liter; µS/cm, microsiemens per centimeter at 25 degrees Celsius]

Constituent or Property		Units	T-163	M-154	N-67	N-68	P-35	Hg-31
Acidity	Acidity as CaCO ₃	mg/L					X	
Alk	Alkalinity as CaCO ₃	mg/L		X				
Ag	Silver	µg/L	X					
Al	Aluminum	µg/L	X					
As	Arsenic	µg/L	X					
B	Boron	µg/L	X	X				
Ba	Barium	µg/L	X					
Be	Beryllium	µg/L	X					
Ca	Calcium	mg/L	X	X			X	
Cd	Cadmium	µg/L	X					
Cl	Chloride	mg/L		X			X	
Co	Cobalt	µg/L	X					
Cr	Chromium	µg/L	X					
Cu	Copper	µg/L	X					
ROE	Dissolved Solids	mg/L		X				
F	Fluoride	mg/L		X			X	
Fe	Iron	µg/L	X					
Hg	Mercury	µg/L						X
K	Potassium	mg/L	X	X			X	
Li	Lithium	µg/L	X					
Mg	Magnesium	mg/L	X	X			X	
Mn	Manganese	µg/L	X					
Mo	Molybdenum	µg/L	X					
Na	Sodium	mg/L	X	X			X	
NH ₃ as N	Ammonia	mg/L			X	X		
NH ₃ + Org N as N	Ammonia + Organic N	mg/L			X	X		
Ni	Nickel	µg/L	X					
NO ₃ as N	Nitrate	mg/L			X	X		
Pb	Lead	µg/L	X					
pH	pH	unit		X			X	
PO ₄ as P	Orthophosphate	mg/L			X	X	X	
total P as P	Phosphorus	mg/L		X	X	X		
Sb	Antimony	µg/L	X					
Se	Selenium	µg/L	X					
SiO ₂	Silica	mg/L	X	X				
SO ₄	Sulfate	mg/L		X			X	
Sp Cond	Specific Conductance	µS/cm		X			X	
Sr	Strontium	µg/L	X	X				
Tl	Thallium	µg/L	X					
U	Uranium	µg/L	X					
V	Vanadium	µg/L	X	X				
Zn	Zinc	µg/L	X					

Laboratories were requested to identify the method used for each constituent according to analytical method codes in the list of definitions, abbreviations and symbols (page IV).

Participating laboratories were also asked to identify the method used, such as those references listed next, to further define the methods.

1. American Public Health Association, American Water Works Association, and Water Environment Federation, 1995, Standard methods for the examination of water and wastewater (19th ed.): Washington, D.C., American Public Health Association, variable pagination.
2. American Society for Testing and Materials, 1995, Annual book of ASTM standards: Philadelphia, v. 11.0, and v. 11.02.3.
3. Kopp, J.F., and McKee, G.F., 1979, Methods for chemical analysis of water and wastes: Cincinnati, U.S. Environmental Protection Agency, EPA 600/4-79-020, rev. 1983,460 p.
4. Fishman, M.J., and Friedman, L.C., eds., 1989. Methods for determination of inorganic substances in water and fluvial sediments (3rd ed.): U.S. Geological Survey Techniques of Water-Resources Investigations, Book 5, Chapter A1, 545 p.
5. Miscellaneous manufacturer's instrument manuals or references.

LABORATORY PERFORMANCE RATINGS

To facilitate laboratory intercomparison, laboratory performance ratings that are based on the analyses reported for each SRS are included in tables 4 - 17 in this report. For each SRS, averages of all the analyte ratings and the number of analyte values reported are given for each participating laboratory. In some cases, laboratory significant figures reported in tables 4 - 17 might have been reformatted because of software formatting requirements. For example, a reported value of 15 may have been changed to 15.0 or a value of 102.86 may have been changed to 102.9 in these tables. However, the actual reported values by all the laboratories were used to calculate the statistical results and performance ratings presented in the report. Laboratory determination of each analyte is rated on a scale 4 to 0, based on the absolute Z-value. The listing of ratings and Z-values are presented in the list of analytical methods, abbreviations, and symbols given on page IV.

A weighted laboratory rating that is greater than or equal to 2.0 is considered satisfactory, whereas ratings less than 2.0 are considered unsatisfactory. Ratings are based on the relative performance of laboratories on specific samples and should be reviewed and evaluated on a case-by-case basis for each laboratory considering such factors as methods used and data needs of specific USGS projects using the laboratory data.

STATISTICAL PRESENTATION OF DATA

Data in this report are evaluated using nonparametric statistics as described by Hoaglin and others (1983). This statistical approach is a resistant statistic because outliers have less influence on the median, as they do the mean in traditional parametric statistics. Analytical data for each analyte are presented in tabular and graphical forms in tables 11 - 16. Tabulated data for each analyte include the laboratory code number; reported values; analytical method; most probable value (MPV); number of reported analyses, excluding less than values, (N); data range; the F-pseudostandard deviation; and the Z-value. The Z-value is equivalent to the Z-score of traditional statistics. The F-pseudostandard deviation approximates the standard deviation (σ) of traditional statistics when the data has a Gaussian distribution. If an analyte has a sufficient number of analyses by a given method, usually 7, the F-pseudostandard deviation for that analytical method is reported in the block of data listed for each analyte.

The median value calculated from the reported results is the MPV. The F-pseudostandard deviation is calculated by dividing the fourth-spread by 1.349; therefore the smaller the F-pseudostandard deviation the more precise the determinations.

The graphical plot of the reported data is shown in figure 1. The upper and lower boundaries of the graphical plots generally are +3 and -3 F-pseudostandard deviation deviations from the median. Reported values are grouped by analytical method in ascending order of value.

In some cases, if the F-pseudostandard deviation is less than 5 percent of the MPV, the rating criterion is set to 5 percent of the MPV; as shown in Table 11, page 46.

The term "insufficient data" is included in some of the tables and is used when the number of analyses is less than seven or the calculated F-pseudostandard deviation is greater than the MPV. An estimated MPV may be calculated from the available data for a single analytical method, this estimated concentration is denoted by MPV = Estimated. Estimated values are not used to rate laboratories.

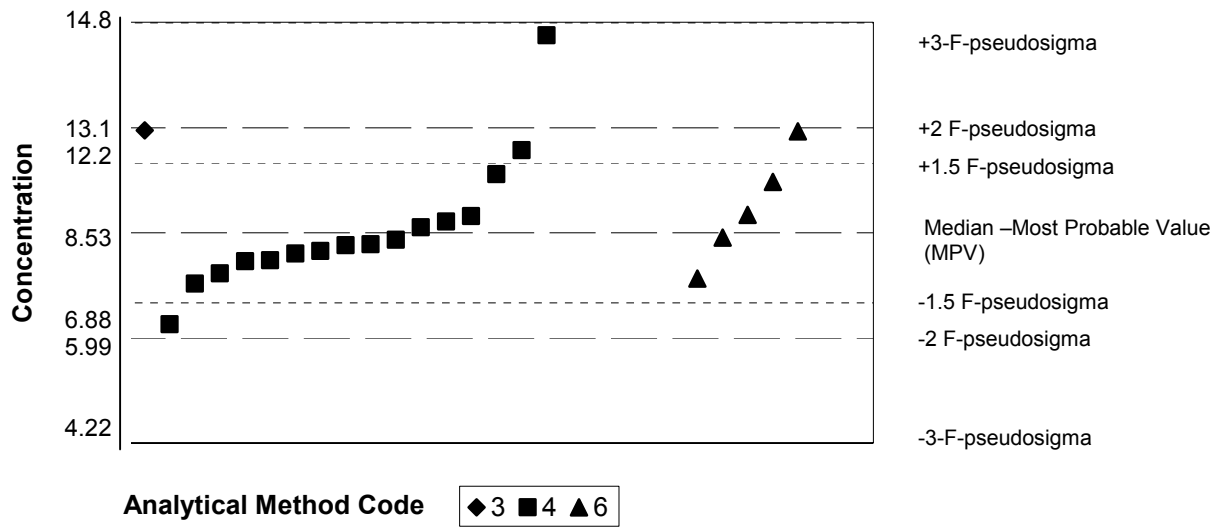

NOTE: vertical scale is the concentration value of the individual analyte in appropriate units (see table 2). Horizontal scale is the laboratory reported values separated by method (different symbols) and plotted by increasing values. Numbers next to each symbol at the bottom of the figure are analytical method codes that are described in table 3. Laboratory-reported results greater than 3 F-pseudosigma from the median are not shown on the graphs.

Figure 1. Statistical parameters shown on data graphs in tables 11 – 16

REFERENCE

Hoaglin, D.C., Mosteller, F., and Tukey, J.W., Eds. 1983, Understanding robust and exploratory data analysis: New York, NY, John Wiley, Inc., p. 38-41.

Table 4. Overall laboratory performance ratings for standard reference samples distributed October 2000

[SRS, standard reference sample; Lab, laboratory; OWR, overall weighted rating for all sample types; OLR, overall laboratory rating for reported values of sample; V/66, number of reported values of 66 possible values from all sample types; V/28, V/16, V/5, V/5, V/11, and V/1 are number of reported values possible for T-163, M-156, N-67, N-68, P-35, and Hg-31 respectively; --, not reported.]

Lab	SRS=		T-163		M-156		N-67		N-68		P-35		Hg-31	
	OWR	V/66	OLR	V/28	OLR	V/16	OLR	V/5	OLR	V/5	OLR	V/11	OLR	V/1
1	3.6	63	3.6	28	3.5	15	3.6	5	3.8	5	3.3	9	4.0	1
2	3.3	9	--	--	--	--	--	--	--	--	3.3	9	--	--
5	2.2	10	--	--	--	--	1.8	5	2.6	5	--	--	--	--
10	3.5	22	3.1	9	3.8	12	--	--	--	--	--	--	4.0	1
12	2.8	33	2.3	12	3.5	10	2.4	5	3.4	5	--	--	0.0	1
13	2.8	46	3.1	23	2.8	14	2.3	4	2.3	4	--	--	1.0	1
18	2.7	36	3.2	18	2.9	7	1.6	5	2.6	5	--	--	0.0	1
21	3.8	6	4.0	1	--	--	3.8	5	--	--	--	--	--	--
23	2.8	54	3.0	21	2.4	13	2.2	5	3.2	5	2.9	10	--	--
24	3.6	27	3.6	14	3.5	13	--	--	--	--	--	--	--	--
25	1.7	63	1.1	26	2.5	16	1.8	5	2.0	5	1.7	11	--	--
26	0.0	2	--	--	--	--	--	--	0.0	2	--	--	--	--
31	3.8	5	--	--	--	--	3.8	5	--	--	--	--	--	--
32	3.4	26	3.4	26	--	--	--	--	--	--	--	--	--	--
38	3.0	25	--	--	3.3	8	3.0	5	2.4	5	3.1	7	--	--
42	3.2	48	3.5	27	3.3	15	1.7	3	1.7	3	--	--	--	--
45	2.6	41	2.2	12	2.9	12	2.3	3	4.0	3	2.4	10	4.0	1
46	2.9	10	--	--	--	--	2.2	5	3.6	5	--	--	--	--
48	2.9	57	3.2	24	3.0	13	1.4	5	3.0	5	3.4	9	0.0	1
50	3.6	41	3.5	26	3.7	14	--	--	--	--	--	--	3.0	1
51	3.4	10	--	--	3.8	5	3.0	5	--	--	--	--	--	--
55	3.6	7	--	--	3.5	6	--	--	--	--	--	--	4.0	1
57	2.4	43	2.4	27	2.3	16	--	--	--	--	--	--	--	--
59	3.0	47	2.5	19	3.3	12	3.6	5	3.8	5	2.8	5	3.0	1
64	3.3	30	3.0	5	3.3	10	3.0	3	3.7	3	3.6	9	--	--
69	3.0	32	3.0	20	2.9	10	4.0	1	4.0	1	--	--	--	--
70	2.5	43	2.7	20	2.5	13	2.2	5	2.2	5	--	--	--	--
72	0.9	10	--	--	--	--	0.4	5	1.4	5	--	--	--	--
76	3.8	18	4.0	12	3.5	6	--	--	--	--	--	--	--	--
81	2.6	60	2.0	24	3.4	14	2.8	5	3.4	5	2.6	11	4.0	1
83	3.8	8	--	--	--	--	3.8	4	3.8	4	--	--	--	--
84	2.5	2	--	--	--	--	--	--	2.5	2	--	--	--	--
86	2.8	47	2.8	20	3.2	13	1.0	3	2.7	3	2.8	8	--	--
87	2.4	41	1.8	18	3.2	12	2.8	5	3.0	5	--	--	0.0	1
88	0.7	6	--	--	--	--	0.0	3	1.3	3	--	--	--	--
89	2.7	59	2.0	23	2.7	14	3.8	5	3.6	5	3.0	11	4.0	1
90	3.0	6	--	--	--	--	3.3	3	2.7	3	--	--	--	--
93	2.6	29	--	--	2.9	11	1.8	4	2.5	4	2.5	10	--	--
96	3.3	34	3.1	16	3.7	7	3.8	5	3.6	5	--	--	0.0	1
97	2.9	33	2.4	13	3.8	9	2.4	5	3.4	5	--	--	3.0	1
105	3.2	65	3.6	27	3.1	16	2.8	5	3.3	5	2.6	11	3.0	1
107	2.7	27	2.8	16	2.5	4	--	--	2.5	4	3.5	2	2.0	1
109	2.8	19	2.8	8	2.8	11	--	--	--	--	--	--	--	--
110	3.6	14	3.2	5	--	--	4.0	1	--	--	3.9	8	--	--
113	3.7	51	3.7	21	3.6	14	3.8	5	3.8	4	3.9	7	--	--
114	3.3	10	--	--	3.3	7	3.0	2	4.0	1	--	--	--	--
118	2.0	30	1.7	12	2.9	7	0.0	5	4.0	5	--	--	0.0	1
121	2.9	22	2.6	17	3.8	5	--	--	--	--	--	--	--	--
127	2.9	55	2.8	28	2.9	16	2.8	5	3.2	5	--	--	4.0	1
129	2.8	22	--	--	3.0	12	2.8	5	2.2	5	--	--	--	--

Table 4. Overall laboratory performance ratings for standard reference samples distributed October 2000 - Continued

[SRS, standard reference sample; Lab, laboratory; OWR, overall weighted rating for all sample types; OLR, overall laboratory rating for reported values of sample; V/66, number of reported values of 66 possible values from all sample types; V/28, V/16, V/5, V/5, V/11, and V/1 are number of reported values possible for T-163, M-156, N-67, N-68, P-35, and Hg-31 respectively; --, not reported.]

Lab	SRS=		T-163		M-156		N-67		N-68		P-35		Hg-31	
	OWR	V/66	OLR	V/28	OLR	V/16	OLR	V/5	OLR	V/5	OLR	V/11	OLR	V/1
131	2.0	4	--	--	2.0	4	--	--	--	--	--	--	--	--
134	3.7	65	3.7	28	3.8	16	3.6	5	3.2	5	3.8	10	4.0	1
138	3.3	62	3.2	25	3.4	16	3.6	5	3.8	5	3.1	10	3.0	1
140	2.4	47	2.3	15	2.7	12	2.4	5	1.8	5	2.5	10	--	--
142	2.8	54	2.9	27	2.6	16	2.6	5	2.8	5	--	--	3.0	1
144	2.0	11	1.9	10	--	--	--	--	--	--	--	--	3.0	1
147	3.8	8	4.0	7	--	--	--	--	--	--	--	--	2.0	1
151	3.0	1	--	--	--	--	3.0	1	--	--	--	--	--	--
154	3.0	47	3.0	23	3.3	14	2.6	5	3.0	5	--	--	--	--
155	3.0	22	--	--	3.1	7	3.2	5	3.0	5	2.4	5	--	--
180	1.2	55	0.0	23	0.0	12	3.6	5	3.0	5	3.6	10	--	--
183	2.6	10	--	--	2.0	3	3.5	2	3.5	2	2.0	3	--	--
190	3.2	45	3.0	14	2.9	13	4.0	4	3.0	4	3.6	10	--	--
193	3.1	36	3.3	16	3.4	7	2.5	4	1.8	4	3.8	5	--	--
198	3.0	24	3.0	23	--	--	--	--	--	--	--	--	3.0	1
203	2.9	47	3.1	18	3.3	10	2.2	5	2.4	5	2.7	8	4.0	1
204	3.0	31	3.0	20	2.8	4	--	--	3.0	5	3.5	2	--	--
208	2.8	6	--	--	2.5	2	--	--	2.0	2	4.0	2	--	--
209	3.0	2	--	--	--	--	2.0	1	4.0	1	--	--	--	--
212	2.7	54	2.6	28	3.1	15	2.8	5	2.4	5	--	--	2.0	1
213	2.7	13	--	--	3.5	4	2.5	4	2.7	4	--	--	0.0	1
215	1.5	46	1.6	16	2.5	11	0.2	5	0.6	5	1.6	8	1.0	1
220	2.6	36	3.1	14	3.0	9	1.5	2	2.5	2	1.6	8	0.0	1
224	2.5	10	--	--	--	--	1.8	5	3.2	5	--	--	--	--
230	2.1	10	--	--	2.1	10	--	--	--	--	--	--	--	--
234	3.4	51	3.6	26	3.3	16	3.8	4	2.8	4	--	--	4.0	1
235	3.5	31	3.7	23	3.0	8	--	--	--	--	--	--	--	--
243	3.7	10	--	--	4.0	2	3.7	3	3.3	3	4.0	2	--	--
247	2.9	65	2.9	27	3.1	16	2.0	5	2.6	5	2.9	11	4.0	1
254	3.2	21	3.3	13	3.1	8	--	--	--	--	--	--	--	--
255	3.4	23	3.2	14	4.0	5	--	--	--	--	3.5	4	--	--
256	1.7	33	1.9	18	2.5	8	--	--	--	--	0.5	7	--	--
257	2.4	22	1.1	10	3.4	12	--	--	--	--	--	--	--	--
258	1.5	12	--	--	1.5	12	--	--	--	--	--	--	--	--
259	3.7	15	--	--	3.7	15	--	--	--	--	--	--	--	--
261	0.8	12	0.0	4	1.1	8	--	--	--	--	--	--	--	--
263	3.5	10	--	--	3.5	10	--	--	--	--	--	--	--	--
265	3.4	46	3.6	28	3.3	11	--	--	--	--	3.0	6	2.0	1
266	3.8	11	--	--	3.8	11	--	--	--	--	--	--	--	--
267	3.6	7	--	--	3.6	7	--	--	--	--	--	--	--	--
268	2.6	21	2.5	4	2.8	9	--	--	--	--	2.5	8	--	--
270	0.9	29	1.2	16	0.6	8	--	--	--	--	0.4	5	--	--
273	2.3	46	2.3	20	2.6	15	--	--	--	--	2.0	11	--	--
274	1.3	34	1.1	11	1.8	12	--	--	--	--	0.8	11	--	--
275	1.9	9	--	--	1.9	9	--	--	--	--	--	--	--	--
276	2.4	8	--	--	2.4	8	--	--	--	--	--	--	--	--
277	2.3	28	2.2	14	2.4	11	--	--	--	--	2.0	2	4.0	1
279	1.2	18	1.0	4	1.3	7	--	--	--	--	1.1	7	--	--
280	3.0	5	--	--	3.0	5	--	--	--	--	--	--	--	--
287	2.2	35	2.2	10	3.2	10	0.0	3	0.7	3	2.3	9	--	--

Table 5. Laboratory performance ratings for standard reference sample T-163 (trace constituents)

[MPV, most probable value; µg/L, micrograms per liter; Lab, laboratory number; OLR, overall laboratory rating for all reported values; V/28, number of reported values of 28 possible values; RV, reported value; <, less than; NR, not rated; --, not reported; mg/L, milligrams per liter.]

<u>Rating</u>	<u>Absolute Z-value</u>	<u>Rating</u>	<u>Absolute Z-value</u>
4 (Excellent)	0.00 - 0.50	1 (Marginal)	1.51 - 2.00
3 (Good)	0.51 - 1.00	0 (Unacceptable)	greater than 2.00
2 (Satisfactory)	1.01 - 1.50	NR (Not Rated)	

Analyte =			Silver		Aluminum		Arsenic		Boron		Barium	
MPV =			16.9 µg/L		16.8 µg/L		25.3 µg/L		10.6 µg/L		7.40 µg/L	
F-pseudosigma =			1.47		1.67		1.78		2.39		0.537	
Lab	OLR	V/28	RV	Rating	RV	Rating	RV	Rating	RV	Rating	RV	Rating
1	3.6	28	17.48	4	17.4	4	24.55	4	<12	NR	7.49	4
10	3.1	9	--	--	--	--	27.7	2	--	--	--	--
12	2.3	12	8.7	0	--	--	22.2	1	--	--	--	--
13	3.1	23	16.8	4	17.7	3	22.7	2	--	--	6.5	1
18	3.2	18	17.12	4	17.4	4	25.8	4	--	--	7.67	4
21	4.0	1	--	--	--	--	--	--	--	--	--	--
23	3.0	21	16.5	4	17.3	4	25.7	4	--	--	9.22	0
24	3.6	14	--	--	--	--	--	--	--	--	7	3
25	1.1	26	17.4	4	<4.6	NR	17.7	0	<2	NR	6	0
32	3.4	26	17.6	4	16.8	4	26	4	10.6	4	7.2	4
42	3.5	27	17.4	4	15.9	3	24.1	3	8.39	3	7.11	3
45	2.2	12	--	--	--	--	25.7	4	--	--	--	--
48	3.2	24	15.3	2	21	0	24.7	4	10.5	4	8.2	2
50	3.5	26	16.7	4	16.8	4	24.4	4	--	--	7.2	4
57	2.4	27	18.2	3	29.1	0	25.3	4	13.4	2	7.6	4
59	2.5	19	14.4	1	15.9	3	26.5	3	--	--	8	2
64	3.0	5	--	--	--	--	--	--	--	--	--	--
69	3.0	20	16.5	4	<50	NR	24.3	3	--	--	--	--
70	2.7	20	--	--	18.6	2	--	--	--	--	7.92	3
76	4.0	12	--	--	--	--	--	--	--	--	--	--
81	2.0	24	13	0	<15	NR	24	3	--	--	6	0
86	2.8	20	17.7	3	--	--	20.1	0	--	--	7.9	3
87	1.8	18	16.7	4	--	--	27	3	--	--	10	0
89	2.0	23	16.2	4	21.5	0	25.4	4	--	--	<50	NR
96	3.1	16	17.2	4	--	--	25.3	4	--	--	<100	NR
97	2.4	13	14.7	2	--	--	26	4	--	--	--	--
105	3.6	27	16.9	4	17.7	3	26.2	4	<200	NR	7.4	4
107	2.8	16	17.2	4	15.6	3	25.7	4	--	--	7.4	4
109	2.8	8	--	--	--	--	24.7	4	--	--	--	--
110	3.2	5	--	--	14.54	2	--	--	--	--	--	--
113	3.7	21	18.5	2	18.5	2	25.9	4	--	--	7.17	4
118	1.7	12	15.62	3	--	--	33.4	0	--	--	--	--
121	2.6	17	--	--	--	--	--	--	--	--	7	3
127	2.8	28	20.5	0	<60	NR	23.2	2	<8	NR	7.31	4
134	3.7	28	16.6	4	16.74	4	26.5	3	10.64	4	7.466	4
138	3.2	25	17.8	3	14.7	2	26.2	4	11.2	4	7.26	4
140	2.3	15	7	0	--	--	--	--	--	--	10	0
142	2.9	27	16.9	4	<30	NR	26.1	4	<30	NR	7.45	4
144	1.9	10	17.6	4	--	--	22.6	1	--	--	--	--
147	4.0	7	--	--	--	--	25.5	4	--	--	--	--
154	3.0	23	--	--	16.4	4	23.7	3	--	--	7.4	4
180	0.0	23	<3.72	NR	<23.8	NR	--	--	69.4	0	39.5	0
190	3.0	14	14	1	16.2	4	23.6	3	--	--	--	--
193	3.3	16	17.5	4	--	--	25.3	4	--	--	--	--
198	3.0	23	17.7	3	16.4	4	23.2	2	--	--	7.17	4

Table 5. Laboratory performance ratings for standard reference sample T-163 (trace constituents) -- Continued

[MPV, most probable value; µg/L, micrograms per liter; Lab, laboratory number; OLR, overall laboratory rating for all reported values; V/28, number of reported values of 28 possible values; RV, reported value; <, less than; NR, not rated; --, not reported; mg/L, milligrams per liter.]

Rating	Absolute Z-value	Rating	Absolute Z-value
4 (Excellent)	0.00 - 0.50	1 (Marginal)	1.51 - 2.00
3 (Good)	0.51 - 1.00	0 (Unacceptable)	greater than 2.00
2 (Satisfactory)	1.01 - 1.50	NR (Not Rated)	

Analyte =			Silver		Aluminum		Arsenic		Boron		Barium	
MPV =			16.9 µg/L		16.8 µg/L		25.3 µg/L		10.6 µg/L		7.40 µg/L	
F-pseudosigma =			1.47		1.67		1.78		2.39		0.537	
Lab	OLR	V/28	RV	Rating	RV	Rating	RV	Rating	RV	Rating	RV	Rating
203	3.1	18	16.4	4	<14	NR	25.8	4	--	--	9.2	0
204	3.0	20	13.2	0	17.6	4	26.2	4	--	--	7.55	4
212	2.6	28	16.3	4	27.1	0	24.3	3	11.3	4	7	3
215	1.6	16	18	3	--	--	19	0	--	--	--	--
220	3.1	14	16.89	4	--	--	27.2	2	--	--	--	--
234	3.6	26	17.6	4	16.7	4	23.6	3	9.08	3	7.4	4
235	3.7	23	17.6	4	16.4	4	--	--	10.87	4	7.4	4
247	2.9	27	16.6	4	16.1	4	21.2	0	5.73	0	7.32	4
254	3.3	13	--	--	<20	NR	--	--	--	--	--	--
255	3.2	14	17.5	4	--	--	26	4	7.65	2	--	--
256	1.9	18	21	0	14	1	28	1	--	--	7	3
257	1.1	10	<20	NR	--	--	16.3	0	--	--	--	--
261	0.0	4	--	--	--	--	--	--	--	--	--	--
265	3.6	28	17.4	4	16.5	4	26	4	10	4	7.5	4
268	2.5	4	--	--	--	--	--	--	--	--	--	--
270	1.2	16	8.33	0	--	--	--	--	--	--	7.83	3
273	2.3	20	18.5	2	--	--	--	--	6.5	1	7	3
274	1.1	11	--	--	--	--	--	--	--	--	--	--
277	2.2	14	11.2	0	--	--	26	4	--	--	--	--
279	1.0	4	--	--	--	--	--	--	--	--	--	--
287	2.2	10	--	--	26.5	0	--	--	--	--	--	--
297	2.5	23	18.4	2	<200	NR	25.3	4	--	--	7.56	4
304	3.9	17	17.4	4	16.8	4	25.2	4	--	--	7.36	4
305	2.6	19	17.9	3	--	--	28.1	1	--	--	7.05	3
306	0.8	7	15.59	3	--	--	--	--	--	--	--	--
307	1.3	12	14.5	1	--	--	22.1	1	--	--	--	--
309	0.9	8	--	--	--	--	--	--	7	2	9	0
315	2.3	6	--	--	--	--	--	--	--	--	--	--
324	0.2	5	--	--	26.6	0	--	--	--	--	--	--
328	1.7	28	16.5	4	<100	NR	26	4	16	0	8.2	2
331	2.2	27	13	0	24	0	21	0	<80	NR	7	3
334	3.0	7	17.3	4	--	--	22.2	1	--	--	--	--

Table 5. Laboratory performance ratings for standard reference sample T-163 (trace constituents) -- Continued

[MPV, most probable value; µg/L, micrograms per liter; Lab, laboratory number; OLR, overall laboratory rating for all reported values; V/28, number of reported values of 28 possible values; RV, reported value; <, less than; NR, not rated; --, not reported; mg/L, milligrams per liter.]

Rating	Absolute Z-value	Rating	Absolute Z-value
4 (Excellent)	0.00 - 0.50	1 (Marginal)	1.51 - 2.00
3 (Good)	0.51 - 1.00	0 (Unacceptable)	greater than 2.00
2 (Satisfactory)	1.01 - 1.50	NR (Not Rated)	

Lab	Analyte = MPV = F-pseudostigma =		Beryllium 22.0 µg/L 1.04		Calcium 6.30 mg/L 0.259		Cadmium 6.59 µg/L 0.419		Cobalt 12.0 µg/L 0.371		Chromium 40.1 µg/L 2.15	
	RV	Rating	RV	Rating	RV	Rating	RV	Rating	RV	Rating	RV	Rating
1	23.16	2	6.468	3	6.76	4	12.8	2	40.93	4		
10	--	--	--	--	6.4	4	--	--	40.1	4		
12	--	--	6.3	4	4	0	--	--	49	0		
13	22	4	6.3	4	6.3	3	<50	NR	40.8	4		
18	22.49	4	--	--	6.59	4	12.4	3	40.8	4		
21	--	--	--	--	--	--	--	--	--	--		
23	21.3	3	6.21	4	6.26	3	--	--	37.6	2		
24	--	--	6.1	3	--	--	12	4	39	3		
25	21.6	4	5.38	0	6	2	10.3	0	47.9	0		
32	22.6	3	6.3	4	6.7	4	12.5	3	40.5	4		
42	21.4	3	6.38	4	6.44	4	12.1	4	40.9	4		
45	--	--	6.33	4	--	--	--	--	--	--		
48	21	3	6.65	2	6.5	4	12.1	4	39	3		
50	21.1	3	6.18	4	6.4	4	11.9	4	39.3	4		
57	21.2	3	6.17	4	5.96	2	12	4	34.6	0		
59	22.8	3	6.5	3	7.1	2	--	--	38.3	3		
64	--	--	6.19	4	--	--	--	--	--	--		
69	22	4	5.72	1	6.2	3	--	--	41.4	3		
70	24.5	0	6.61	3	6.75	4	12.7	2	42	3		
76	22.06	4	6.288	4	6.601	4	12.02	4	40.16	4		
81	18.8	0	6.37	4	7	3	11	1	52	0		
86	22.1	4	6.47	3	7.7	0	9	0	41	4		
87	--	--	4.62	0	4.8	0	--	--	41.8	3		
89	21.9	4	4.09	0	7.06	2	10.8	1	43.4	1		
96	20.4	2	--	--	6.53	4	12.7	2	37.9	2		
97	19	0	6.15	4	5.8	1	--	--	42.6	2		
105	22	4	6.23	4	6.5	4	11.9	4	39.6	4		
107	--	--	7.5	0	7	3	--	--	37.1	2		
109	--	--	6.5	3	--	--	--	--	--	--		
110	--	--	6.45	4	--	--	--	--	--	--		
113	22.9	3	6.2	4	6.6	4	--	--	39.7	4		
118	--	--	--	--	7.85	0	--	--	--	--		
121	--	--	6.43	4	7	3	11	1	36	1		
127	23.4	2	5.85	2	6.38	4	11.8	4	41.8	3		
134	21.63	4	6.265	4	6.68	4	12.19	4	40.13	4		
138	21.1	3	6.11	3	6.41	4	11.9	4	37.5	2		
140	--	--	5.7	1	7	3	--	--	46	0		
142	21.2	3	6.81	1	6.94	3	11.9	4	38.6	3		
144	20	1	--	--	7.1	2	--	--	38.4	3		
147	--	--	--	--	6.7	4	--	--	--	--		
154	22	4	6.1	3	5.37	0	12.2	4	39.5	4		
180	<0.6	NR	30	0	<3.78	NR	<3.98	NR	<4.5	NR		
190	--	--	6.45	4	6.83	3	--	--	37.8	2		
193	23	3	6.18	4	6.4	4	--	--	41.4	3		
198	22.6	3	5.53	0	6.44	4	12.3	4	38	3		

Table 5. Laboratory performance ratings for standard reference sample T-163 (trace constituents) -- Continued

[MPV, most probable value; µg/L, micrograms per liter; Lab, laboratory number; OLR, overall laboratory rating for all reported values; V/28, number of reported values of 28 possible values; RV, reported value; <, less than; NR, not rated; --, not reported; mg/L, milligrams per liter.]

Rating	Absolute Z-value	Rating	Absolute Z-value
4 (Excellent)	0.00 - 0.50	1 (Marginal)	1.51 - 2.00
3 (Good)	0.51 - 1.00	0 (Unacceptable)	greater than 2.00
2 (Satisfactory)	1.01 - 1.50	NR (Not Rated)	

Analyte = MPV = F-pseudosigma =	Copper		Iron		Potassium		Lithium		Magnesium	
	RV	Rating	RV	Rating	RV	Rating	RV	Rating	RV	Rating
1	36.92	3	63.207	3	1.02	4	1.189	4	1.27	3
10	36	4	63	4	--	--	--	--	--	--
12	35.7	4	64	3	--	--	--	--	1.32	2
13	31.2	0	56.3	3	0.99	4	--	--	1.3	3
18	40	0	--	--	--	--	--	--	--	--
21	--	--	60.87	4	--	--	--	--	--	--
23	33.2	2	60	4	0.94	3	--	--	1.18	3
24	35	4	61	4	0.96	4	--	--	1.18	3
25	39.7	0	62.5	4	1.078	4	9	0	1.053	0
32	36	4	--	--	1.02	4	1.08	3	1.3	3
42	35.8	4	61.1	4	0.986	4	<5	NR	1.23	4
45	36.5	4	72.5	0	0.694	0	--	--	0.94	0
48	35	4	71	1	0.97	4	--	--	1.22	4
50	34.5	3	54.1	3	0.928	3	0.96	3	1.23	4
57	37.2	3	59.5	4	1.48	0	1.6	4	1.31	2
59	34.2	3	--	--	1	4	--	--	1.3	3
64	--	--	26.5	0	0.99	4	--	--	1.21	4
69	<50	NR	<50	NR	1	4	<50	NR	<2.0	NR
70	36.7	4	38	0	1.04	4	--	--	1.26	4
76	--	--	--	--	--	--	--	--	1.249	4
81	37	3	42	0	1.17	2	--	--	1.23	4
86	35.6	4	--	--	1	4	--	--	1.27	3
87	38.3	2	60.4	4	944	0	--	--	1.14	2
89	34	3	60	4	0.885	3	--	--	1.29	3
96	36	4	60	4	--	--	--	--	--	--
97	--	--	--	--	--	--	--	--	1.2	4
105	36	4	67	2	<1.00	NR	<26.0	NR	1.22	4
107	32.6	1	60	4	1.18	2	--	--	1.22	4
109	--	--	52.33	2	1.12	3	2.44	3	1.5	0
110	--	--	--	--	1.08	4	--	--	1.299	3
113	36.2	4	59.6	4	1	4	--	--	1.22	4
118	45.1	0	98	0	--	--	--	--	--	--
121	33	1	58	4	--	--	--	--	1.16	3
127	32.9	1	61.8	4	1.03	4	<10	NR	1.35	1
134	35.9	4	58	4	0.978	4	1.1	4	1.199	4
138	35.5	4	55.2	3	0.968	4	--	--	1.19	3
140	37	3	60	4	0.95	3	--	--	1.2	4
142	33.6	2	62	4	<1	NR	--	--	1.55	0
144	31.6	0	--	--	--	--	--	--	--	--
147	35.3	4	59	4	--	--	--	--	--	--
154	35	4	62.1	4	--	--	--	--	1.1	1
180	3.23	0	<3.81	NR	2.19	0	--	--	6.73	0
190	37.5	3	62.4	4	--	--	--	--	--	--
193	35.9	4	59	4	0.991	4	--	--	1.24	4
198	32.8	1	60.7	4	0.89	3	--	--	1.13	2

Table 5. Laboratory performance ratings for standard reference sample T-163 (trace constituents) -- Continued

[MPV, most probable value; µg/L, micrograms per liter; Lab, laboratory number; OLR, overall laboratory rating for all reported values; V/28, number of reported values of 28 possible values; RV, reported value; <, less than; NR, not rated; --, not reported; mg/L, milligrams per liter.]

Rating	Absolute Z-value	Rating	Absolute Z-value
4 (Excellent)	0.00 - 0.50	1 (Marginal)	1.51 - 2.00
3 (Good)	0.51 - 1.00	0 (Unacceptable)	greater than 2.00
2 (Satisfactory)	1.01 - 1.50	NR (Not Rated)	

Analyte =	Copper		Iron		Potassium		Lithium		Magnesium	
MPV =	35.8 µg/L		60.0 µg/L		1.02 mg/L		1.60 µg/L		1.23 mg/L	
F-pseudosigma =	1.74		5.93		0.137		0.993		0.074	
Lab	RV	Rating	RV	Rating	RV	Rating	RV	Rating	RV	Rating
203	36	4	55	3	1.02	4	--	--	1.13	2
204	37.3	3	52	2	1.14	3	--	--	1.25	4
212	34.7	3	74.9	0	1.02	4	<10	NR	1.18	3
215	45	0	72	0	--	--	--	--	14	0
220	36.13	4	55.64	3	1.038	4	--	--	1.21	4
234	36.7	4	63.4	3	1.02	4	--	--	1.25	4
235	35.1	4	59.7	4	0.985	4	0.91	3	1.16	3
247	34.6	3	55.04	3	1	4	2.31	3	1.16	3
254	36.7	4	61.8	4	1.21	2	--	--	1.24	4
255	36.4	4	54.5	3	--	--	--	--	1.22	4
256	--	--	54	2	--	--	2	4	--	--
257	35	4	--	--	--	--	<25	NR	--	--
261	--	--	20	0	--	--	--	--	35.3	0
265	36	4	65	3	0.93	3	1.2	4	1.25	4
268	--	--	--	--	1.21	2	--	--	1.216	4
270	40.54	0	40.85	0	1.14	3	5.05	0	--	--
273	21.6	0	63	4	1.05	4	6	0	1.26	4
274	39.81	0	61.33	4	0.96	4	--	--	2.13	0
277	33	1	52.1	2	1.25	1	--	--	--	--
279	--	--	--	--	0.66	0	--	--	4.15	0
287	33.5	2	68	2	1.036	4	--	--	1.24	4
297	37.8	2	68.3	2	1.37	0	--	--	1.31	2
304	35	4	--	--	--	--	--	--	--	--
305	36.7	4	52	2	1.47	0	--	--	1.21	4
306	56.98	0	--	--	1.483	0	--	--	--	--
307	31.8	0	5.6	0	--	--	--	--	--	--
309	--	--	--	--	4	0	--	--	1.13	2
315	--	--	0.022	0	1.13	3	--	--	1.2	4
324	--	--	94.6	0	--	--	--	--	--	--
328	35	4	53	2	1.56	0	<10	NR	1.3	3
331	34	3	62	4	1.3	0	<2	NR	1.51	0
334	35.6	4	78	0	--	--	--	--	--	--

Table 5. Laboratory performance ratings for standard reference sample T-163 (trace constituents) -- Continued

[MPV, most probable value; µg/L, micrograms per liter; Lab, laboratory number; OLR, overall laboratory rating for all reported values; V/28, number of reported values of 28 possible values; RV, reported value; <, less than; NR, not rated; --, not reported; mg/L, milligrams per liter.]

<u>Rating</u>	<u>Absolute Z-value</u>	<u>Rating</u>	<u>Absolute Z-value</u>
4 (Excellent)	0.00 - 0.50	1 (Marginal)	1.51 - 2.00
3 (Good)	0.51 - 1.00	0 (Unacceptable)	greater than 2.00
2 (Satisfactory)	1.01 - 1.50	NR (Not Rated)	

Lab	Analyte =		Manganese		Molybdenum		Sodium		Nickel		Lead	
	MPV =		15.8 µg/L		12.6 µg/L		39.6 mg/L		15.4 µg/L		32.0 µg/L	
	F-pseudosigma =		1.11		0.926		1.89		1.26		2.17	
	RV	Rating	RV	Rating	RV	Rating	RV	Rating	RV	Rating	RV	Rating
1	15.49	4	12.997	4	41.71	2	15.7	4	32.7	4		
10	17.6	1	--	--	--	--	--	--	29	2		
12	--	--	--	--	38.7	4	--	--	32.3	4		
13	17.2	2	--	--	40.6	4	<20	NR	30.6	3		
18	16.03	4	12.01	3	--	--	15.65	4	34.49	2		
21	--	--	--	--	--	--	--	--	--	--		
23	14.9	3	13.3	3	37.4	2	14.5	3	30.6	3		
24	16	4	--	--	39.5	4	--	--	--	--		
25	11.7	0	--	--	37.9	3	10	0	26.9	0		
32	16.5	3	12.6	4	42	2	14.7	3	32.1	4		
42	15.5	4	12	3	39.4	4	15.5	4	32.6	4		
45	17	2	--	--	37.55	2	22	0	33.6	3		
48	16.8	3	13	4	40.5	4	15	4	33	4		
50	14.8	3	12.5	4	40.8	3	14.9	4	29.7	2		
57	15.1	3	10.9	1	3.81	0	15.6	4	30.4	3		
59	15.1	3	--	--	46.9	0	14.2	3	34.5	2		
64	--	--	--	--	--	--	--	--	--	--		
69	<20	NR	--	--	39.8	4	<50	NR	32.8	4		
70	17	2	13.4	3	42.5	2	15.9	4	--	--		
76	--	--	--	--	--	--	15.18	4	--	--		
81	15	3	11	1	40.9	3	6	0	28	1		
86	15.8	4	--	--	40.5	4	17.3	2	32	4		
87	17.2	2	9.5	0	38.6	4	10.4	0	35	2		
89	19.2	0	--	--	38.5	3	14.5	3	26.1	0		
96	<20.0	NR	--	--	--	--	14.1	2	33.4	3		
97	--	--	10.7	1	--	--	15.8	4	31	4		
105	16.4	3	13.7	2	39.6	4	15.9	4	34.4	2		
107	<40	NR	--	--	40.4	4	14.2	3	35	2		
109	16.5	3	--	--	39.8	4	--	--	--	--		
110	--	--	--	--	--	--	--	--	--	--		
113	15.5	4	--	--	40.2	4	15.5	4	33	4		
118	16.5	3	--	--	40	4	15.9	4	30.6	3		
121	15	3	11	1	40.2	4	14	2	32	4		
127	14.3	2	15.1	0	40	4	13.9	2	31.6	4		
134	15.75	4	12.19	4	40.68	3	15.49	4	32	4		
138	15.2	3	12.6	4	39	4	17.5	1	32.3	4		
140	15	3	--	--	37.5	2	17	2	32	4		
142	<10	NR	12.6	4	43.3	1	14.8	4	30.4	3		
144	--	--	--	--	--	--	12.2	0	34.4	2		
147	16.1	4	--	--	--	--	--	--	33.1	4		
154	15.5	4	12.1	4	36.4	1	15.3	4	28.8	2		
180	<0.94	NR	<6.05	NR	44.7	0	<15.6	NR	<28.5	NR		
190	15.3	4	--	--	--	--	15.8	4	31.3	4		
193	--	--	--	--	38.8	4	16.4	3	31.5	4		
198	14.9	3	12.8	4	36.4	1	14.2	3	30.5	3		

Table 5. Laboratory performance ratings for standard reference sample T-163 (trace constituents) -- Continued

[MPV, most probable value; µg/L, micrograms per liter; Lab, laboratory number; OLR, overall laboratory rating for all reported values; V/28, number of reported values of 28 possible values; RV, reported value; <, less than; NR, not rated; --, not reported; mg/L, milligrams per liter.]

Rating	Absolute Z-value	Rating	Absolute Z-value
4 (Excellent)	0.00 - 0.50	1 (Marginal)	1.51 - 2.00
3 (Good)	0.51 - 1.00	0 (Unacceptable)	greater than 2.00
2 (Satisfactory)	1.01 - 1.50	NR (Not Rated)	

Lab	Analyte =		Manganese		Molybdenum		Sodium		Nickel		Lead	
	MPV =	F-pseudosigma =	RV	Rating	RV	Rating	RV	Rating	RV	Rating	RV	Rating
			15.8 µg/L		12.6 µg/L		39.6 mg/L		15.4 µg/L		32.0 µg/L	
			1.11		0.926		1.89		1.26		2.17	
203			9	0	--	--	40.36	4	<30	NR	29.8	2
204			15.6	4	--	--	41.7	2	14.2	3	38.3	0
212			16.4	3	10	0	39.6	4	16.3	3	29	2
215			18	1	--	--	42	2	29	0	15	0
220			--	--	--	--	37.715	3	--	--	27.7	1
234			15.9	4	11.7	3	39.5	4	15.7	4	31.7	4
235			15.27	4	--	--	38.4	3	15.17	4	31.24	4
247			12.6	0	12.5	4	39.356	4	14.8	4	33	4
254			15.9	4	--	--	40.4	4	<15	NR	--	--
255			16.5	3	--	--	--	--	16.7	2	34.6	2
256			17	2	--	--	--	--	16	4	35	2
257			--	--	--	--	--	--	17	2	47.5	0
261			--	--	--	--	--	--	--	--	--	--
265			16.5	3	12.8	4	39.7	4	15.5	4	32	4
268			--	--	--	--	38.9	4	--	--	--	--
270			16.8	3	--	--	38.1	3	30.29	0	--	--
273			16.5	3	13.6	2	40	4	18.5	0	19.6	0
274			72.82	0	--	--	48.75	0	--	--	48.66	0
277			14.1	1	--	--	24.8	0	13.6	2	33.3	3
279			--	--	--	--	28.45	0	--	--	--	--
287			14	1	--	--	38.08	3	--	--	30.15	3
297			16.2	4	--	--	36.2	1	17.9	1	31.8	4
304			16	4	--	--	--	--	15.4	4	32	4
305			15.5	4	12.6	4	33.9	0	14.2	3	35.7	1
306			--	--	--	--	50.9	0	11.45	0	--	--
307			4.5	0	--	--	41.5	3	14	2	28.6	1
309			--	--	--	--	35.7	1	--	--	--	--
315			0.014	0	--	--	38.4	3	--	--	--	--
324			18.1	0	--	--	--	--	--	--	--	--
328			21	0	11.8	3	43	1	13	1	28	1
331			15	3	14	1	34.7	0	14	2	29	2
334			15.4	4	--	--	--	--	15.8	4	32.5	4

Table 5. Laboratory performance ratings for standard reference sample T-163 (trace constituents) -- Continued

[MPV, most probable value; µg/L, micrograms per liter; Lab, laboratory number; OLR, overall laboratory rating for all reported values; V/28, number of reported values of 28 possible values; RV, reported value; <, less than; NR, not rated; --, not reported; mg/L, milligrams per liter.]

<u>Rating</u>	<u>Absolute Z-value</u>	<u>Rating</u>	<u>Absolute Z-value</u>
4 (Excellent)	0.00 - 0.50	1 (Marginal)	1.51 - 2.00
3 (Good)	0.51 - 1.00	0 (Unacceptable)	greater than 2.00
2 (Satisfactory)	1.01 - 1.50	NR (Not Rated)	

Lab	Antimony		Selenium		Silica		Strontium		Thallium	
	32.5 µg/L		8.88 µg/L		4.56 mg/L		35.5 µg/L		39.9 µg/L	
	RV	Rating	RV	Rating	RV	Rating	RV	Rating	RV	Rating
1	32.14	4	9.09	4	4.654	4	34.16	3	39.634	4
10	--	--	9	4	--	--	--	--	--	--
12	--	--	7.4	2	--	--	--	--	--	--
13	32.1	4	9.8	3	4.4	3	--	--	37.1	3
18	37.5	0	9.21	4	--	--	--	--	42.5	3
21	--	--	--	--	--	--	--	--	--	--
23	35.4	1	8.8	4	--	--	--	--	38.8	4
24	--	--	--	--	4.73	3	36	4	--	--
25	<60	NR	<11	NR	1.88	0	24.5	0	<7.5	NR
32	34.5	2	--	--	4.93	1	35	4	40	4
42	31.9	4	8.53	4	3.88	0	35.7	4	41.6	3
45	34	3	--	--	--	--	--	--	--	--
48	35	2	8.1	3	--	--	--	--	42	3
50	31.8	4	8.73	4	4.62	4	36.1	4	36	2
57	31.7	4	13	0	4.25	2	34.5	3	41.6	3
59	35.5	1	9.6	3	--	--	--	--	44.3	2
64	--	--	--	--	4.43	3	--	--	--	--
69	28.3	0	8	3	--	--	--	--	42.3	3
70	34.8	2	8.95	4	4.83	2	--	--	--	--
76	33.06	4	--	--	--	--	35.43	4	40.97	4
81	30	2	8	3	--	--	36	4	44	2
86	--	--	8.74	4	--	--	36.7	3	31.9	0
87	--	--	2.1	0	4.45	4	--	--	--	--
89	28.9	1	5.62	0	4.6	4	--	--	46.4	0
96	32.2	4	8.03	3	--	--	--	--	--	--
97	--	--	--	--	4.41	3	33.5	2	--	--
105	32.6	4	9.4	4	4.47	4	34	3	39.8	4
107	--	--	10.1	2	--	--	--	--	--	--
109	--	--	--	--	--	--	--	--	--	--
110	--	--	--	--	4.759	3	--	--	--	--
113	31.9	4	8.57	4	--	--	34.8	4	37.7	3
118	--	--	7.65	2	2.23	0	--	--	--	--
121	--	--	--	--	4.57	4	32	1	--	--
127	29.8	2	9.71	3	4.64	4	34.5	3	38.3	3
134	33.88	3	10	2	4.453	4	35.2	4	40.04	4
138	33.1	4	9.63	3	--	--	33.4	2	43.7	2
140	--	--	--	--	4.63	4	--	--	--	--
142	38.5	0	9.63	3	4.9	2	37	3	40.5	4
144	--	--	7.5	2	--	--	--	--	--	--
147	--	--	--	--	--	--	--	--	--	--
154	34.2	3	9.8	3	4.6	4	35.6	4	34.2	1
180	<26.6	NR	<65.2	NR	--	--	--	--	<37.9	NR
190	--	--	8.16	3	5.1	0	--	--	--	--
193	29	1	9.7	3	--	--	--	--	--	--
198	31.2	3	9.13	4	--	--	--	--	37.9	3

Table 5. Laboratory performance ratings for standard reference sample T-163 (trace constituents) -- Continued

[MPV, most probable value; µg/L, micrograms per liter; Lab, laboratory number; OLR, overall laboratory rating for all reported values; V/28, number of reported values of 28 possible values; RV, reported value; <, less than; NR, not rated; --, not reported; mg/L, milligrams per liter.]

Rating	Absolute Z-value	Rating	Absolute Z-value
4 (Excellent)	0.00 - 0.50	1 (Marginal)	1.51 - 2.00
3 (Good)	0.51 - 1.00	0 (Unacceptable)	greater than 2.00
2 (Satisfactory)	1.01 - 1.50	NR (Not Rated)	

Analyte =	Uranium		Vanadium		Zinc	
MPV =	4.60 µg/L		35.0 µg/L		18.5 µg/L	
F-pseudostigma =	0.156		1.78		1.33	
Lab	RV	Rating	RV	Rating	RV	Rating
1	4.59	4	34.27	4	18.27	4
10	--	--	--	--	19.5	3
12	--	--	--	--	19.5	3
13	--	--	<50	NR	18.7	4
18	--	--	36.54	3	17.31	3
21	--	--	--	--	--	--
23	--	--	--	--	18.5	4
24	--	--	34	3	18	4
25	--	--	36.4	3	25	0
32	4.6	4	36	3	17.3	3
42	--	--	34.5	4	17.5	3
45	--	--	--	--	18	4
48	--	--	35	4	19	4
50	--	--	33.7	3	17.7	3
57	--	--	33.5	3	23.7	0
59	--	--	--	--	19.6	3
64	--	--	--	--	--	--
69	--	--	--	--	<50	NR
70	--	--	36.4	3	20	2
76	4.7	4	35.48	4	--	--
81	--	--	34	3	19	4
86	--	--	36.7	3	18.9	4
87	--	--	--	--	19.6	3
89	--	--	37.7	1	18.4	4
96	--	--	<40	NR	17	2
97	--	--	30.5	0	--	--
105	--	--	34.3	4	18	4
107	--	--	--	--	--	--
109	--	--	--	--	--	--
110	--	--	--	--	--	--
113	--	--	--	--	18.4	4
118	--	--	--	--	16	1
121	--	--	33	2	18	4
127	<100	NR	34.4	4	18.8	4
134	5.07	0	34.99	4	18.63	4
138	--	--	33.7	3	18.3	4
140	--	--	--	--	21	1
142	4.62	4	34	3	18.4	4
144	--	--	--	--	18	4
147	--	--	--	--	18.4	4
154	--	--	34.6	4	15.1	0
180	--	--	<5.97	NR	12	0
190	--	--	--	--	19.4	3
193	--	--	--	--	25	0
198	--	--	36.5	3	17.8	4

Table 5. Laboratory performance ratings for standard reference sample T-163 (trace constituents) -- Continued

[MPV, most probable value; µg/L, micrograms per liter; Lab, laboratory number; OLR, overall laboratory rating for all reported values; V/28, number of reported values of 28 possible values; RV, reported value; <, less than; NR, not rated; --, not reported; mg/L, milligrams per liter.]

Rating	Absolute Z-value	Rating	Absolute Z-value
4 (Excellent)	0.00 - 0.50	1 (Marginal)	1.51 - 2.00
3 (Good)	0.51 - 1.00	0 (Unacceptable)	greater than 2.00
2 (Satisfactory)	1.01 - 1.50	NR (Not Rated)	

Analyte =	Uranium		Vanadium		Zinc	
MPV =	4.60 µg/L		35.0 µg/L		18.5 µg/L	
F-pseudosigma =	0.156		1.78		1.33	
Lab	RV	Rating	RV	Rating	RV	Rating
203	--	--	--	--	17.4	3
204	--	--	--	--	17.8	4
212	4.4	3	33.8	3	18.9	4
215	--	--	--	--	18	4
220	--	--	35.96	3	--	--
234	--	--	35	4	19.6	3
235	--	--	33.6	3	19.51	3
247	--	--	34.2	4	11.4	0
254	--	--	--	--	19	4
255	--	--	--	--	18.5	4
256	--	--	37	2	15	0
257	--	--	--	--	50	0
261	--	--	--	--	55.5	0
265	4.5	4	37	2	18	4
268	--	--	--	--	--	--
270	--	--	--	--	22.93	0
273	--	--	--	--	21.1	1
274	--	--	--	--	15.55	0
277	--	--	--	--	17.1	2
279	--	--	--	--	--	--
287	--	--	--	--	15	0
297	--	--	36.7	3	18.2	4
304	--	--	34.2	4	17.9	4
305	--	--	35.6	4	19.4	3
306	--	--	--	--	<50	NR
307	--	--	--	--	23	0
309	--	--	--	--	--	--
315	--	--	--	--	--	--
324	--	--	--	--	20.7	1
328	3.6	0	42	0	22	0
331	--	--	35	4	21	1
334	--	--	--	--	--	--

Table 6. Laboratory performance ratings for standard reference sample M-156 (major constituents)

[MPV, most probable value; mg/L, milligrams per liter; µg/L, micrograms per liter; Lab, laboratory number; OLR, overall laboratory rating for all reported values; V/16, number of reported values of 16 possible values; RV, reported value; --, not reported; <, less than; NR, not rated.]

Rating	Absolute Z-value	Rating	Absolute Z-value
4 (Excellent)	0.00 - 0.50	1 (Marginal)	1.51 - 2.00
3 (Good)	0.51 - 1.00	0 (Unacceptable)	greater than 2.00
2 (Satisfactory)	1.01 - 1.50	NR (Not Rated)	

Analyte =			Alkalinity		Boron		Calcium		Chloride		Fluoride	
MPV =			61.8 mg/L		78.6 µg/L		30.2 mg/L		64.7 mg/L		0.523 mg/L	
F-pseudostigma =			2.52		5.11		1.13		1.87		0.045	
Lab	OLR	V/16	RV	Rating	RV	Rating	RV	Rating	RV	Rating	RV	Rating
1	3.5	15	62.87	4	76.257	4	30.433	4	64.28	4	0.511	4
10	3.8	12	61	4	--	--	29.98	4	64.1	4	0.51	4
12	3.5	10	62.2	4	--	--	30	4	62.5	3	--	--
13	2.8	14	58.2	2	--	--	31.2	3	63	3	0.46	2
18	2.9	7	58.8	3	--	--	--	--	64.4	4	0.5	4
23	2.4	13	60.8	4	--	--	76.4	0	66.1	4	0.54	4
24	3.5	13	62.3	4	77	4	30	4	62.9	3	0.54	4
25	2.5	16	66	2	61	0	29.2	3	65.2	4	0.53	4
38	3.3	8	61.72	4	--	--	29.45	4	--	--	--	--
42	3.3	15	61	4	76.3	4	30.4	4	65.9	4	0.444	1
45	2.9	12	62.4	4	--	--	29.69	4	64.6	4	0.472	2
48	3.0	13	62	4	76	4	31.4	3	70	1	--	--
50	3.7	14	60	3	80.6	4	30.16	4	62.9	3	0.523	4
51	3.8	5	--	--	--	--	--	--	62.7	3	--	--
55	3.5	6	62	4	--	--	--	--	65	4	0.56	3
57	2.3	16	64	3	89.2	0	29.6	4	70	1	0.49	3
59	3.3	12	58.7	3	--	--	30	4	65	4	0.53	4
64	3.3	10	--	--	--	--	30.8	4	65.4	4	--	--
69	2.9	10	57.8	2	--	--	28.7	3	64.3	4	0.53	4
70	2.5	13	60.8	4	--	--	31.2	3	65.5	4	0.58	2
76	3.5	6	--	--	--	--	30.43	4	66.6	3	--	--
81	3.4	14	61.7	4	--	--	30.6	4	63.6	4	0.489	3
86	3.2	13	--	--	82.5	3	30.3	4	67.4	3	0.585	2
87	3.2	12	60.2	4	--	--	27.5	1	64	4	--	--
89	2.7	14	62.9	4	--	--	28.2	2	64.6	4	0.58	2
93	2.9	11	62.12	4	--	--	30.4	4	67.5	3	0.489	3
96	3.7	7	59.5	3	--	--	--	--	64.4	4	0.519	4
97	3.8	9	61.3	4	--	--	--	--	64.7	4	0.518	4
105	3.1	16	61.4	4	<200	NR	32.6	1	67	3	0.48	3
107	2.5	4	60.3	4	--	--	--	--	69.7	1	0.565	3
109	2.8	11	65.6	2	--	--	29.4	4	57	0	0.48	3
113	3.6	14	61.8	4	--	--	29.7	4	64.7	4	0.518	4
114	3.3	7	62.8	4	--	--	--	--	63.5	4	0.56	3
118	2.9	7	61	4	--	--	--	--	--	--	--	--
121	3.8	5	--	--	--	--	30.2	4	--	--	--	--
127	2.9	16	62.6	4	75.5	3	31.3	3	64.1	4	0.476	2
129	3.0	12	64	3	75	3	30	4	68	2	--	--
131	2.0	4	--	--	--	--	--	--	67.3	3	0.45	1
134	3.8	16	62.7	4	80.52	4	30.15	4	64.79	4	0.49	3
138	3.4	16	61.5	4	85.7	2	29.8	4	62.4	3	0.535	4
140	2.7	12	--	--	--	--	29.25	3	64.61	4	0.566	3
142	2.6	16	62	4	80.5	4	32.5	1	64.5	4	0.55	3
154	3.3	14	64	3	--	--	31.2	3	64.6	4	0.567	3
155	3.1	7	59.4	3	--	--	30.918	4	--	--	--	--
180	0.0	12	--	--	<21.9	NR	6.3	0	47.1	0	0.155	0
183	2.0	3	--	--	--	--	--	--	60.71	2	0.64	0
190	2.9	13	59	3	--	--	32.5	1	65.2	4	0.539	4
193	3.4	7	62.6	4	--	--	29.1	3	--	--	--	--
203	3.3	10	57.8	2	--	--	29.48	4	--	--	--	--
204	2.8	4	59	3	--	--	--	--	62.2	3	--	--

Table 6. Laboratory performance ratings for standard reference sample M-156 (major constituents) -- Continued

[MPV, most probable value; mg/L, milligrams per liter; µg/L, micrograms per liter; Lab, laboratory number; OLR, overall laboratory rating for all reported values; V/16, number of reported values of 16 possible values; RV, reported value; --, not reported; <, less than; NR, not rated.]

Rating	Absolute Z-value	Rating	Absolute Z-value
4 (Excellent)	0.00 - 0.50	1 (Marginal)	1.51 - 2.00
3 (Good)	0.51 - 1.00	0 (Unacceptable)	greater than 2.00
2 (Satisfactory)	1.01 - 1.50	NR (Not Rated)	

Analyte =			Alkalinity		Boron		Calcium		Chloride		Fluoride	
MPV =			61.8 mg/L		78.6 µg/L		30.2 mg/L		64.7 mg/L		0.523 mg/L	
F-pseudosigma =			2.52		5.11		1.13		1.87		0.045	
Lab	OLR	V/16	RV	Rating	RV	Rating	RV	Rating	RV	Rating	RV	Rating
208	2.5	2	--	--	--	--	--	--	59.8	1	--	--
212	3.1	15	60.1	3	79.3	4	30.3	4	65.3	4	0.53	4
213	3.5	4	59	3	--	--	--	--	64	4	--	--
215	2.5	11	63	4	--	--	33	1	--	--	0.52	4
220	3.0	9	57.101	2	78.23	4	30.73	4	63.02	3	--	--
230	2.1	10	59.1	3	--	--	30.84	4	66.97	3	0.73	0
234	3.3	16	63	4	87.1	1	29.8	4	63.9	4	0.549	3
235	3.0	8	--	--	75.6	3	29.4	4	--	--	--	--
243	4.0	2	--	--	--	--	--	--	--	--	--	--
247	3.1	16	55.6	1	78.4	4	30	4	65.5	4	0.4	0
254	3.1	8	--	--	--	--	31.1	3	64.8	4	--	--
255	4.0	5	--	--	80.6	4	30.3	4	--	--	0.506	4
256	2.5	8	--	--	--	--	--	--	64.21	4	--	--
257	3.4	12	61.5	4	--	--	30.4	4	67.5	3	0.51	4
258	1.5	12	60.2	4	90	0	23.14	0	72.8	0	0.734	0
259	3.7	15	62	4	78.8	4	30	4	65	4	0.53	4
261	1.1	8	--	--	--	--	64	0	69.97	1	--	--
263	3.5	10	62	4	--	--	30	4	65	4	0.49	3
265	3.3	11	--	--	87	1	30.8	4	63.7	4	0.47	2
266	3.8	11	62	4	--	--	30	4	64.5	4	0.51	4
267	3.6	7	62.3	4	--	--	30.9	4	65.3	4	--	--
268	2.8	9	61.9	4	--	--	26.95	0	63.5	4	--	--
270	0.6	8	--	--	--	--	13.16	0	--	--	0.31	0
273	2.6	15	67.6	1	61.5	0	31	3	65.4	4	0.623	0
274	1.8	12	72.12	0	--	--	29.14	3	70.78	1	0.57	2
275	1.9	9	51	0	--	--	32	2	59	1	--	--
276	2.4	8	64.4	3	--	--	--	--	71	1	--	--
277	2.4	11	118	0	--	--	31.9	2	66.3	4	0.46	2
279	1.3	7	--	--	--	--	23.95	0	66.25	4	--	--
280	3.0	5	--	--	--	--	30	4	67	3	--	--
287	3.2	10	62	4	--	--	30.49	4	62.7	3	0.54	4
297	1.8	11	56	1	--	--	27	0	65	4	--	--
304	2.0	2	--	--	--	--	--	--	51	0	--	--
305	2.8	9	64	3	--	--	29.5	4	--	--	0.48	3
306	2.0	6	--	--	--	--	--	--	65.5	4	--	--
307	2.7	7	65	2	--	--	--	--	64.5	4	--	--
309	1.7	11	64.2	3	71	2	34.3	0	72	0	--	--
315	2.8	6	--	--	--	--	29.6	4	70.6	1	--	--
323	3.3	14	--	--	89.2	0	29.4	4	66	4	0.53	4
324	0.7	6	55.2	0	--	--	23.4	0	--	--	--	--
328	2.1	16	59	3	70	1	31	3	60	2	0.64	0
331	1.9	16	58	2	<80	NR	35.5	0	64.7	4	0.55	3
333	3.6	5	58.4	2	--	--	--	--	--	--	--	--
334	2.0	6	86.1	0	--	--	32	2	62.9	3	--	--

Table 6. Laboratory performance ratings for standard reference sample M-156 (major constituents) -- Continued

[MPV, most probable value; mg/L, milligrams per liter; µg/L, micrograms per liter; Lab, laboratory number; OLR, overall laboratory rating for all reported values; V/16, number of reported values of 16 possible values; RV, reported value; --, not reported; <, less than; NR, not rated.]

Rating	Absolute Z-value	Rating	Absolute Z-value
4 (Excellent)	0.00 - 0.50	1 (Marginal)	1.51 - 2.00
3 (Good)	0.51 - 1.00	0 (Unacceptable)	greater than 2.00
2 (Satisfactory)	1.01 - 1.50	NR (Not Rated)	

Analyte =	pH		Potassium		Magnesium		Sodium		Phosphorus	
MPV =	7.95		2.13 mg/L		6.92 mg/L		44.6 mg/L		0.578 mg/L	
F-pseudosigma =	0.203		0.163		0.319		2.30		0.039	
Lab	RV	Rating	RV	Rating	RV	Rating	RV	Rating	RV	Rating
208	--	--	--	--	--	--	--	--	--	--
212	8.2	3	2.37	2	6.98	4	47	2	0.43	0
213	7.95	4	--	--	--	--	--	--	0.54	3
215	7.95	4	--	--	7.5	1	48	2	0.58	4
220	--	--	2.28	3	6.54	2	45.6	4	0.595	4
230	8.2	3	2.82	0	6.19	0	45.47	4	--	--
234	8.08	4	1.96	2	6.8	4	44.6	4	0.65	1
235	--	--	2.05	4	6.28	1	42	2	--	--
243	7.91	4	--	--	--	--	--	--	--	--
247	8.11	4	2.06	4	6.7	3	44.2	4	0.541	3
254	--	--	2.21	3	7.13	3	46.7	3	--	--
255	--	--	--	--	6.82	4	--	--	--	--
256	7.96	4	--	--	7.9	0	34.79	0	--	--
257	7.9	4	2	3	7	4	42.5	3	0.58	4
258	7.68	3	2.58	0	13.46	0	35.1	0	--	--
259	8.14	4	1.87	1	6.77	4	44.3	4	0.54	3
261	7.96	4	0.31	0	46.4	0	45	4	--	--
263	8.05	4	--	--	7	4	--	--	--	--
265	--	--	2.1	4	6.9	4	45.7	4	--	--
266	8.12	4	2.2	4	7	4	44.5	4	--	--
267	8.1	4	--	--	7.3	2	--	--	0.6	3
268	7.73	3	2.42	1	6.52	2	45.5	4	--	--
270	--	--	14.66	0	14.68	0	47	2	4.71	0
273	7.98	4	2.2	4	7.3	2	46.4	3	0.57	4
274	7.57	3	2.11	4	7.57	1	50	0	0.63	2
275	--	--	2.4	1	7.5	1	49	1	--	--
276	7.94	4	2	3	--	--	52.5	0	--	--
277	7.81	4	2.57	0	7.35	2	41.9	2	--	--
279	7.5	2	1.45	0	18.94	0	28.5	0	--	--
280	8	4	--	--	7.8	0	--	--	--	--
287	7.84	4	2.23	3	6.49	2	44.03	4	--	--
297	8.06	4	3.2	0	7.69	0	43	3	0.619	2
304	--	--	--	--	--	--	--	--	--	--
305	8.2	3	2.78	0	6.99	4	37.3	0	0.587	4
306	7.8	4	2.38	1	--	--	56.88	0	0.678	0
307	8.2	3	--	--	--	--	44.5	4	0.578	4
309	7.8	4	5	0	6.9	4	42.7	3	--	--
315	--	--	2.4	1	6.8	4	43.1	3	--	--
323	7.8	4	2.22	3	6.76	4	43.8	4	0.584	4
324	7.8	4	--	--	--	--	--	--	--	--
328	7.72	3	2	3	6.9	4	45	4	0.6	3
331	7.98	4	2.95	0	7.96	0	41.5	2	0.57	4
333	8.12	4	--	--	--	--	--	--	--	--
334	--	--	--	--	7.08	4	47.7	2	--	--

**Table 6. Laboratory performance ratings for standard reference sample M-156 (major constituents) --
Continued**

[MPV, most probable value; mg/L, milligrams per liter; µg/L, micrograms per liter; Lab, laboratory number; OLR, overall laboratory rating for all reported values; V/16, number of reported values of 16 possible values; RV, reported value; --, not reported; <, less than; NR, not rated.]

Rating	Absolute Z-value	Rating	Absolute Z-value
4 (Excellent)	0.00 - 0.50	1 (Marginal)	1.51 - 2.00
3 (Good)	0.51 - 1.00	0 (Unacceptable)	greater than 2.00
2 (Satisfactory)	1.01 - 1.50	NR (Not Rated)	

Analyte =	ROE (solids)		Silica		Sulfate		Specific conductance		Strontium	
MPV =	244 mg/L		4.73 mg/L		43.0 mg/L		440 µS/cm		239 µg/L	
F-pseudosigma =	13.4		0.308		1.78		14.8		9.64	
Lab	RV	Rating	RV	Rating	RV	Rating	RV	Rating	RV	Rating
1	245	4	4.872	4	42.3	4	442.3	4	239	4
10	244	4	4.6	4	45.4	2	440	4	--	--
12	255	3	--	--	42.8	4	446	4	--	--
13	206	0	4.7	4	43.5	4	438	4	--	--
18	268	1	4.75	4	38.2	0	--	--	--	--
23	218	1	5.04	3	47.4	0	432	4	--	--
24	--	--	5.04	3	40.8	2	440	4	247	3
25	170	0	4.29	2	44.4	3	464	2	220	1
38	--	--	4.76	4	--	--	--	--	--	--
42	--	--	4.07	0	44.4	3	449	4	250	3
45	230	2	--	--	43	4	443	4	--	--
48	251	3	--	--	50	0	449	4	--	--
50	255	3	4.873	4	43.4	4	442	4	--	--
51	--	--	--	--	42.3	4	432	4	--	--
55	250	4	--	--	46.2	2	--	--	--	--
57	230	2	4.55	3	36	0	390	0	233	4
59	243	4	4.37	2	41.86	3	439	4	--	--
64	--	--	4.73	4	44	4	459	3	--	--
69	228	2	--	--	42.5	4	--	--	--	--
70	266	1	5.08	2	47.8	0	452	3	--	--
76	241.3	4	--	--	42.57	4	--	--	--	--
81	245	4	--	--	39.8	2	425	3	244	4
86	--	--	--	--	48	0	446	4	244	4
87	242	4	4.76	4	43	4	400	1	--	--
89	239	4	4.8	4	41.2	3	26.6	0	--	--
93	--	--	4.38	2	44.9	3	416.3	2	--	--
96	249	4	--	--	45	3	447	4	--	--
97	243	4	4.59	4	42.4	4	446	4	--	--
105	772	0	4.71	4	42.1	4	444	4	225	2
107	--	--	--	--	45.2	2	--	--	--	--
109	243	4	--	--	37.5	0	439	4	--	--
113	271	0	5.1	2	42.3	4	438	4	233	4
114	255	3	--	--	46.1	2	428	3	--	--
118	246	4	2.3	0	--	--	400	1	--	--
121	--	--	4.75	4	--	--	--	--	240	4
127	243	4	5.24	1	42.8	4	243	0	238	4
129	232	3	--	--	40	2	413	2	--	--
131	--	--	--	--	43.7	4	--	--	--	--
134	254.1	3	4.702	4	41.98	4	439.7	4	236.8	4
138	226	2	4.82	4	43.4	4	449	4	226	2
140	230	2	4.7	4	46	2	410	2	--	--
142	260	2	5.52	0	42.9	4	440	4	246	3
154	246	4	4.8	4	43.7	4	389.6	0	239	4
155	--	--	4.9411	3	--	--	422	3	--	--
180	--	--	--	--	4.01	0	2480	0	--	--
183	--	--	--	--	--	--	--	--	--	--
190	248.5	4	5.4	0	43.4	4	448	4	--	--
193	--	--	5.12	2	--	--	436	4	--	--
203	--	--	4.61	4	43.4	4	442	4	--	--
204	--	--	5.13	2	44.4	3	--	--	--	--

Table 6. Laboratory performance ratings for standard reference sample M-156 (major constituents) -- Continued

[MPV, most probable value; mg/L, milligrams per liter; µg/L, micrograms per liter; Lab, laboratory number; OLR, overall laboratory rating for all reported values; V/16, number of reported values of 16 possible values; RV, reported value; --, not reported; <, less than; NR, not rated.]

Rating	Absolute Z-value	Rating	Absolute Z-value
4 (Excellent)	0.00 - 0.50	1 (Marginal)	1.51 - 2.00
3 (Good)	0.51 - 1.00	0 (Unacceptable)	greater than 2.00
2 (Satisfactory)	1.01 - 1.50	NR (Not Rated)	

Analyte =	ROE (solids)		Silica		Sulfate		Specific conductance		Strontium	
MPV =	244 mg/L		4.73 mg/L		43.0 mg/L		440 µS/cm		239 µg/L	
F-pseudosigma =	13.4		0.308		1.78		14.8		9.64	
Lab	RV	Rating	RV	Rating	RV	Rating	RV	Rating	RV	Rating
208	--	--	--	--	42	4	--	--	--	--
212	--	--	2.34	0	42.3	4	431	4	233	4
213	--	--	--	--	--	--	--	--	--	--
215	245	4	--	--	100	0	438	4	--	--
220	--	--	--	--	39,218	1	--	--	--	--
230	--	--	--	--	42.43	4	390	0	--	--
234	261	2	4.72	4	40.9	3	438	4	236	4
235	--	--	4.61	4	--	--	--	--	235	4
243	--	--	--	--	--	--	449	4	--	--
247	208	0	4.6	4	44.8	3	445	4	237	4
254	--	--	4.94	3	42.8	4	--	--	257	2
255	--	--	--	--	43.7	4	--	--	--	--
256	--	--	3.78	0	42.33	4	447	4	240	4
257	250	4	--	--	45.6	2	467	2	--	--
258	236	3	--	--	43.4	4	440	4	--	--
259	240	4	4.83	4	43	4	444	4	239.5	4
261	--	--	--	--	20	0	368	0	--	--
263	237	3	5.2	1	44	4	448	4	--	--
265	--	--	4.5	3	42	4	--	--	230	3
266	240	4	4.3	2	44	4	--	--	--	--
267	--	--	--	--	--	--	444	4	--	--
268	--	--	--	--	42.6	4	457	3	--	--
270	--	--	--	--	56.77	0	--	--	248.15	3
273	240	4	4.4	2	44	4	448	4	266	0
274	--	--	3.46	0	45.69	2	437	4	--	--
275	235	3	--	--	43	4	450	4	--	--
276	245	4	--	--	20.5	0	440	4	--	--
277	225	2	--	--	42.1	4	432	4	--	--
279	--	--	--	--	--	--	418	3	--	--
280	--	--	--	--	--	--	442	4	--	--
287	--	--	--	--	40.14	2	414	2	--	--
297	--	--	3.09	0	--	--	463	2	--	--
304	--	--	--	--	43	4	--	--	--	--
305	--	--	--	--	--	--	--	--	--	--
306	--	--	--	--	--	--	453.5	3	--	--
307	--	--	--	--	51	0	464	2	--	--
309	--	--	3	0	48	0	--	--	247	3
315	--	--	--	--	43.6	4	--	--	--	--
323	--	--	4.66	4	41.7	3	75	0	237	4
324	277.9	0	--	--	33.1	0	964	0	--	--
328	263	2	5.64	0	39	1	440	4	210	0
331	256	3	5.5	0	44.2	3	327	0	267	0
333	--	--	4.73	4	--	--	441	4	243	4
334	--	--	--	--	46.9	1	--	--	--	--

Table 6. Laboratory performance ratings for standard reference sample M-156 (major constituents) -- Continued

[MPV, most probable value; mg/L, milligrams per liter; µg/L, micrograms per liter; Lab, laboratory number; OLR, overall laboratory rating for all reported values; V/16, number of reported values of 16 possible values; RV, reported value; --, not reported; <, less than; NR, not rated.]

Rating	Absolute Z-value	Rating	Absolute Z-value
4 (Excellent)	0.00 - 0.50	1 (Marginal)	1.51 - 2.00
3 (Good)	0.51 - 1.00	0 (Unacceptable)	greater than 2.00
2 (Satisfactory)	1.01 - 1.50	NR (Not Rated)	

Analyte = MPV = F-pseudosigma =	Vanadium	
	RV	Rating
Lab		
1	12.08	2
10	--	--
12	--	--
13	<50	NR
18	--	--
23	--	--
24	--	--
25	<0.01	NR
38	--	--
42	10.8	3
45	--	--
48	9.4	4
50	--	--
51	--	--
55	--	--
57	8.83	4
59	--	--
64	--	--
69	--	--
70	--	--
76	--	--
81	9	4
86	11.6	2
87	--	--
89	12.1	2
93	--	--
96	--	--
97	--	--
105	<20.0	NR
107	--	--
109	--	--
113	--	--
114	--	--
118	--	--
121	--	--
127	8.24	3
129	--	--
131	--	--
134	9.06	4
138	9.34	4
140	--	--
142	8.37	3
154	9.8	4
155	--	--
180	22.5	0
183	--	--
190	--	--
193	--	--
203	--	--
204	--	--

Analyte= MPV = F-pseudosigma =	Vanadium	
	RV	Rating
Lab		
208	--	--
212	8.8	4
213	--	--
215	29	0
220	--	--
230	--	--
234	9.66	4
235	7.21	2
243	--	--
247	9.97	4
254	--	--
255	--	--
256	--	--
257	--	--
258	--	--
259	--	--
261	--	--
263	--	--
265	8.5	3
266	--	--
267	--	--
268	--	--
270	--	--
273	--	--
274	--	--
275	--	--
276	--	--
277	--	--
279	--	--
280	--	--
287	--	--
297	9.94	4
304	--	--
305	9.21	4
306	--	--
307	--	--
309	--	--
315	--	--
323	9.23	4
324	--	--
328	14.5	0
331	11	3
333	--	--
334	--	--

Table 7. Laboratory performance ratings for standard reference sample N-67 (nutrient constituents)

[N, nitrogen; MPV, most probable value; mg/L, milligrams per liter; Lab, laboratory number; OLR, overall laboratory rating for all reported values; V/5, number of reported values of 5 possible values; RV, reported value; <, less than; --, not reported; NR, not rated.]

Rating	Absolute Z-value	Rating	Absolute Z-value
4 (Excellent)	0.00 - 0.50	1 (Marginal)	1.51 - 2.00
3 (Good)	0.51 - 1.00	0 (Unacceptable)	greater than 2.00
2 (Satisfactory)	1.01 - 1.50	NR (Not Rated)	

Analyte =			Ammonia as N		Ammonia + Organic N as N		Nitrate as N		Total Phosphorus		Orthophosphate as P	
MPV =			0.433 mg/L		0.450 mg/L		0.222 mg/L		0.279 mg/L		0.274 mg/L	
F-pseudosigma =			0.030		0.059		0.009		0.010		0.013	
Lab	OLR	V/5	RV	Rating	RV	Rating	RV	Rating	RV	Rating	RV	Rating
1	3.6	5	0.433	4	0.451	4	0.21	2	0.279	4	0.274	4
5	1.8	5	0.409	3	0.74	0	0.219	4	0.26	2	0.23	0
12	2.4	5	0.582	0	0.76	0	0.22	4	0.273	4	0.276	4
13	2.3	4	0.48	1	--	--	0.221	4	0.28	4	0.224	0
18	1.6	5	0.289	0	0.58	0	0.196	0	0.273	4	0.276	4
21	3.8	5	0.433	4	0.487	3	0.218	4	0.276	4	0.273	4
23	2.2	5	0.45	3	0.349	1	0.217	4	0.236	0	0.263	3
25	1.8	5	0.39	2	0.78	0	0.226	4	0.25	0	0.267	3
31	3.8	5	0.433	4	0.487	3	0.218	4	0.276	4	0.273	4
38	3.0	5	0.447	4	0.39	2	0.222	4	0.263	2	0.262	3
42	1.7	3	--	--	--	--	0.219	4	0.252	1	0.305	0
45	2.3	3	--	--	--	--	0.23	3	0.25	0	0.28	4
46	2.2	5	0.456	3	0.482	3	0.201	1	0.274	4	0.302	0
48	1.4	5	0.36	0	0.5	3	0.45	0	0.3	2	0.29	2
51	3.0	5	0.45	3	0.45	4	0.26	0	0.272	4	0.27	4
59	3.6	5	0.429	4	0.443	4	0.22	4	0.269	3	0.266	3
64	3.0	3	0.49	1	--	--	0.22	4	--	--	0.278	4
69	4.0	1	--	--	--	--	0.22	4	--	--	--	--
70	2.2	5	0.059	0	0.404	3	0.219	4	0.204	0	0.268	4
72	0.4	5	0.36	0	0.384	2	0.37	0	0.175	0	0.334	0
81	2.8	5	0.421	4	0.42	3	0.238	2	0.29	3	0.288	2
83	3.8	4	0.407	3	--	--	0.22	4	0.28	4	0.274	4
86	1.0	3	0.363	0	--	--	0.191	0	0.266	3	--	--
87	2.8	5	0.41	3	0.41	3	0.25	0	0.277	4	0.268	4
88	0.0	3	0.102	0	--	--	0.105	0	--	--	0.339	0
89	3.8	5	0.433	4	0.477	4	0.223	4	0.27	3	0.27	4
90	3.3	3	0.41	3	0.408	3	0.22	4	--	--	--	--
93	1.8	4	0.46	3	--	--	0.223	4	0.325	0	0.23	0
96	3.8	5	0.433	4	0.413	3	0.224	4	0.28	4	0.268	4
97	2.4	5	0.489	1	0.39	2	0.23	3	0.3	2	0.275	4
105	2.8	5	0.46	3	<1.00	NR	0.23	3	0.27	3	0.29	2
110	4.0	1	0.4466	4	--	--	--	--	--	--	--	--
113	3.8	5	0.45	3	<0.5	NR	0.224	4	0.278	4	0.27	4
114	3.0	2	0.44	4	--	--	--	--	0.26	2	--	--
118	0.0	5	0.04	0	0.06	0	0.03	0	0.03	0	0.03	0
127	2.8	5	0.445	4	0.453	4	0.255	0	0.291	3	0.287	3
129	2.8	5	0.408	3	1.187	0	0.224	4	0.284	4	0.282	3
134	3.6	5	0.441	4	0.474	4	0.23	3	0.283	4	0.283	3
138	3.6	5	0.451	3	0.481	3	0.221	4	0.281	4	0.272	4
140	2.4	5	0.59	0	0.68	0	0.223	4	0.28	4	0.27	4
142	2.6	5	0.451	3	0.384	2	0.252	0	0.279	4	0.273	4
151	3.0	1	0.41	3	--	--	--	--	--	--	--	--
154	2.6	5	0.45	3	0.48	3	0.22	4	0.295	2	0.295	1
155	3.2	5	0.4333	4	0.4353	4	0.1742	0	0.2801	4	0.2716	4
180	3.6	5	0.404	3	0.441	4	0.225	4	0.273	4	0.282	3
183	3.5	2	--	--	--	--	--	--	0.275	4	0.266	3
190	4.0	4	0.436	4	--	--	0.219	4	0.273	4	0.273	4
193	2.5	4	0.4	2	0.41	3	0.23	3	0.258	2	--	--
203	2.2	5	0.45	3	0.26	0	0.21	2	0.284	4	0.257	2
209	2.0	1	--	--	--	--	0.208	2	--	--	--	--

**Table 7. Laboratory performance ratings for standard reference sample N-67 (nutrient constituents) --
Continued**

[N, nitrogen; MPV, most probable value; mg/L, milligrams per liter; Lab, laboratory number; OLR, overall laboratory rating for all reported values; V/5, number of reported values of 5 possible values; RV, reported value; <, less than; --, not reported; NR, not rated.]

Rating	Absolute Z-value	Rating	Absolute Z-value
4 (Excellent)	0.00 - 0.50	1 (Marginal)	1.51 - 2.00
3 (Good)	0.51 - 1.00	0 (Unacceptable)	greater than 2.00
2 (Satisfactory)	1.01 - 1.50	NR (Not Rated)	

Analyte =			Ammonia as N		Ammonia + Organic N as N		Nitrate as N		Total Phosphorus		Orthophosphate as P	
MPV =			0.433 mg/L		0.450 mg/L		0.222 mg/L		0.279 mg/L		0.274 mg/L	
F-pseudosigma =			0.030		0.059		0.009		0.010		0.013	
Lab	OLR	V/5	RV	Rating	RV	Rating	RV	Rating	RV	Rating	RV	Rating
212	2.8	5	0.426	4	0.477	4	0.236	2	0.225	0	0.269	4
213	2.5	4	<1.0	NR	<1.0	NR	--	--	0.27	3	0.26	2
215	0.2	5	0.49	1	0.7	0	1.7	0	0.87	0	0.81	0
220	1.5	2	--	--	--	--	0.248	0	--	--	0.285	3
224	1.8	5	0.48	1	0.553	1	0.229	3	0.3	2	0.291	2
234	3.8	4	0.432	4	--	--	0.216	3	0.284	4	0.28	4
243	3.7	3	0.428	4	--	--	0.23	3	0.28	4	--	--
247	2.0	5	0.38	1	0.352	1	0.19	0	0.286	4	0.27	4
287	0.0	3	0.5	0	--	--	0.64	0	--	--	2.99	0
297	3.0	5	0.464	2	0.428	4	0.244	1	0.281	4	0.272	4
305	2.5	5	0.46	3	<1.0	NR	0.27	0	0.278	4	0.281	3
306	1.8	5	0.472	2	0.648	0	0.216	3	0.308	0	0.276	4
307	3.0	4	0.42	4	--	--	0.232	3	0.283	4	0.296	1
313	2.8	5	0.408	3	0.371	2	0.213	3	0.286	4	0.288	2
316	3.2	5	0.4289	4	0.439	4	0.2204	4	0.3188	0	0.2728	4
318	3.2	5	0.445	4	0.465	4	0.235	2	0.281	4	0.294	2
320	2.4	5	0.414	3	0.665	0	0.212	3	0.283	4	0.256	2
321	1.8	4	5.31	0	--	--	0.21	2	0.301	1	0.272	4
323	3.6	5	0.448	4	0.41	3	0.228	3	0.279	4	0.277	4
328	0.0	5	<.05	NR	0.032	0	<.05	NR	0.33	0	1.01	0
333	3.0	2	0.44	4	--	--	0.234	2	--	--	--	--

Table 8. Laboratory performance ratings for standard reference sample N-68 (nutrient constituents)

[N, nitrogen; MPV, most probable value; mg/L, milligrams per liter; Lab, laboratory number; OLR, overall laboratory rating for all reported values; V/5, number of reported values of 5 possible values; RV, reported value; <, less than; NR, not rated; --, not reported.]

Rating	Absolute Z-value	Rating	Absolute Z-value
4 (Excellent)	0.00 - 0.50	1 (Marginal)	1.51 - 2.00
3 (Good)	0.51 - 1.00	0 (Unacceptable)	greater than 2.00
2 (Satisfactory)	1.01 - 1.50	NR (Not Rated)	

Analyte =			Ammonia as N		Ammonia + Organic N as N		Nitrate as N		Total Phosphorus		Orthophosphate as P	
MPV =			0.480 mg/L		0.650 mg/L		1.68 mg/L		0.830 mg/L		0.809 mg/L	
F-pseudostigma =			0.048		0.103		0.076		0.030		0.035	
Lab	OLR	V/5	RV	Rating	RV	Rating	RV	Rating	RV	Rating	RV	Rating
1	3.8	5	0.466	4	0.635	4	1.624	3	0.837	4	0.81	4
5	2.6	5	1.447	0	0.67	4	1.67	4	0.83	4	0.743	1
12	3.4	5	0.423	2	0.72	3	1.72	4	0.836	4	0.802	4
13	2.3	4	0.52	3	--	--	1.61	3	0.8	3	0.21	0
18	2.6	5	0.346	0	0.83	1	1.68	4	0.811	4	0.82	4
23	3.2	5	0.44	3	0.66	4	1.75	3	0.89	2	0.81	4
25	2.0	5	0.41	2	0.9	0	1.6	3	0.78	2	0.778	3
26	0.0	2	--	--	--	--	1.47	0	--	--	0.64	0
38	2.4	5	0.669	0	0.58	3	1.702	4	0.788	2	0.788	3
42	1.7	3	--	--	--	--	1.684	4	0.75	1	0.724	0
45	4.0	3	--	--	--	--	1.7	4	0.84	4	0.81	4
46	3.6	5	0.534	2	0.619	4	1.66	4	0.812	4	0.817	4
48	3.0	5	0.43	2	0.58	3	1.8	2	0.84	4	0.828	4
59	3.8	5	0.469	4	0.675	4	1.71	4	0.83	4	0.781	3
64	3.7	3	0.46	4	--	--	1.69	4	--	--	0.849	3
69	4.0	1	--	--	--	--	1.7	4	--	--	--	--
70	2.2	5	4.73	0	0.556	3	1.58	2	0.867	3	0.782	3
72	1.4	5	0.4	1	0.597	3	1.83	1	0.773	2	0.909	0
81	3.4	5	0.459	4	0.464	1	1.66	4	0.812	4	0.815	4
83	3.8	4	0.439	3	--	--	1.68	4	0.836	4	0.822	4
84	2.5	2	0.53	2	--	--	1.74	3	--	--	--	--
86	2.7	3	0.444	3	--	--	1.54	1	0.842	4	--	--
87	3.0	5	0.56	1	0.71	3	1.64	4	0.845	4	0.842	3
88	1.3	3	0.04	0	--	--	0.263	0	--	--	0.792	4
89	3.6	5	0.467	4	0.717	3	1.75	3	0.82	4	0.82	4
90	2.7	3	0.439	3	0.486	1	1.697	4	--	--	--	--
93	2.5	4	0.52	3	--	--	1.51	0	0.854	3	0.82	4
96	3.6	5	0.473	4	0.604	4	1.66	4	0.796	3	0.77	3
97	3.4	5	0.489	4	0.56	3	1.76	3	0.8	3	0.807	4
105	3.3	5	0.47	4	<1.00	NR	1.68	4	0.75	1	0.82	4
107	2.5	4	0.657	0	--	--	1.57	2	0.821	4	0.829	4
113	3.8	4	0.488	4	--	--	1.654	4	0.808	3	0.815	4
114	4.0	1	--	--	--	--	--	--	0.84	4	--	--
118	4.0	5	0.47	4	0.66	4	1.72	4	0.85	4	0.79	4
127	3.2	5	0.468	4	0.747	3	1.56	2	0.84	4	0.836	3
129	2.2	5	0.48	4	0.827	1	1.617	3	0.895	1	0.858	2
134	3.2	5	0.582	0	0.666	4	1.717	4	0.831	4	0.809	4
138	3.8	5	0.492	4	0.653	4	1.66	4	0.842	4	0.776	3
140	1.8	5	0.65	0	0.89	0	1.761	3	0.84	4	0.85	2
142	2.8	5	0.572	1	0.678	4	1.59	2	0.824	4	0.83	3
154	3.0	5	0.46	4	0.65	4	1.72	4	0.878	2	0.733	1
155	3.0	5	0.4903	4	0.6042	4	1.487	0	0.8143	4	0.7879	3
180	3.0	5	0.463	4	0.676	4	1.71	4	0.807	3	0.996	0
183	3.5	2	--	--	--	--	--	--	0.833	4	0.77	3
190	3.0	4	0.486	4	--	--	1.99	0	0.813	4	0.812	4
193	1.8	4	0.39	1	0.88	0	1.66	4	0.779	2	--	--
203	2.4	5	0.49	4	0.72	3	1.48	0	0.86	3	0.749	2
204	3.0	5	0.48	4	0.578	3	1.73	3	0.833	4	0.882	1
208	2.0	2	--	--	--	--	1.69	4	--	--	0.7	0
209	4.0	1	--	--	--	--	1.69	4	--	--	--	--

Table 8. Laboratory performance ratings for standard reference sample N-68 (nutrient constituents) -- Continued

[N, nitrogen; MPV, most probable value; mg/L, milligrams per liter; Lab, laboratory number; OLR, overall laboratory rating for all reported values; V/5, number of reported values of 5 possible values; RV, reported value; <, less than; NR, not rated; --, not reported.]

Rating	Absolute Z-value	Rating	Absolute Z-value
4 (Excellent)	0.00 - 0.50	1 (Marginal)	1.51 - 2.00
3 (Good)	0.51 - 1.00	0 (Unacceptable)	greater than 2.00
2 (Satisfactory)	1.01 - 1.50	NR (Not Rated)	

Analyte =			Ammonia as N		Ammonia + Organic N as N		Nitrate as N		Total Phosphorus		Orthophosphate as P	
MPV =			0.480 mg/L		0.650 mg/L		1.68 mg/L		0.830 mg/L		0.809 mg/L	
F-pseudosigma =			0.048		0.103		0.076		0.030		0.035	
Lab	OLR	V/5	RV	Rating	RV	Rating	RV	Rating	RV	Rating	RV	Rating
212	2.4	5	0.569	1	0.588	3	1.65	4	0.648	0	0.797	4
213	2.7	4	<1.0	NR	1.2	0	--	--	0.84	4	0.79	4
215	0.6	5	0.43	2	0.46	1	0.22	0	0.29	0	0.28	0
220	2.5	2	--	--	--	--	1.69	4	--	--	0.88	1
224	3.2	5	0.51	3	0.553	3	1.787	2	0.82	4	0.796	4
234	2.8	4	0.432	3	--	--	1.63	3	0.841	4	0.74	1
243	3.3	3	0.478	4	--	--	1.74	3	0.8	3	--	--
247	2.6	5	0.501	4	0.483	1	1.49	0	0.818	4	0.82	4
287	0.7	3	0.58	0	--	--	1.8	2	--	--	4.62	0
291	0.0	1	--	--	--	--	0.79	0	--	--	--	--
297	2.6	5	0.514	3	0.521	2	1.77	2	0.878	2	0.804	4
305	4.0	4	--	--	<1.0	NR	1.66	4	0.832	4	0.817	4
306	1.4	5	0.498	4	0.57	3	1.48	0	0.734	0	0.724	0
313	3.2	5	0.476	4	0.702	4	1.7	4	0.858	3	0.88	1
314	4.0	5	0.48	4	0.647	4	1.713	4	0.811	4	0.797	4
316	2.6	5	0.4862	4	0.5289	2	1.6826	4	0.9131	0	0.7777	3
320	2.0	5	0.518	3	2.436	0	1.7	4	0.778	2	0.747	1
328	2.2	5	0.45	3	0.495	2	1.74	3	0.8	3	2.45	0

Table 9. Laboratory performance ratings for standard reference sample P-35 (low-ionic strength constituents)

[MPV, most probable value; mg/L, milligrams per liter; Lab, laboratory number; OLR, overall laboratory rating for all reported values; V/11, number of reported values of 11 possible values; RV, reported value; --, not reported; <, less than; NR, not rated; μS/cm, microsiemens per centimeter.]

Rating	Absolute Z-value	Rating	Absolute Z-value
4 (Excellent)	0.00 - 0.50	1 (Marginal)	1.51 - 2.00
3 (Good)	0.51 - 1.00	0 (Unacceptable)	greater than 2.00
2 (Satisfactory)	1.01 - 1.50	NR (Not Rated)	

Lab	Analyte =		Acidity		Calcium		Chloride		Fluoride		Potassium	
	OLR	V/11	RV	Rating	RV	Rating	RV	Rating	RV	Rating	RV	Rating
	MPV =		4.10 mg/L		0.541 mg/L		5.31 mg/L		0.238 mg/L		0.184 mg/L	
	F-pseudostigma =		1.91		0.053		0.432		0.032		0.017	
1	3.3	9	--	--	0.541	4	5.625	3	0.242	4	0.177	4
2	3.3	9	--	--	0.551	4	4.651	1	0.239	4	0.177	4
23	2.9	10	--	--	2.4	0	5.32	4	0.24	4	<0.2	NR
25	1.7	11	<8	NR	0.241	0	5.3	4	0.25	4	0.225	0
38	3.1	7	0.71	1	0.56	4	--	--	--	--	0.19	4
45	2.4	10	--	--	0.38	0	5.02	3	0.21	3	<1	NR
48	3.4	9	--	--	0.527	4	5	3	--	--	0.184	4
59	2.8	5	--	--	--	--	4.12	0	0.23	4	--	--
64	3.6	9	--	--	0.52	4	5.4	4	--	--	0.18	4
81	2.6	11	2.05	2	0.555	4	5.52	4	0.235	4	0.138	0
86	2.8	8	--	--	0.449	1	5.31	4	0.27	3	--	--
89	3.0	11	2.9	3	0.502	3	5.4	4	0.2	2	0.2	3
93	2.5	10	--	--	0.66	0	5.63	3	0.237	4	0.18	4
105	2.6	11	26	0	0.668	0	5	3	0.22	3	<1.00	NR
107	3.5	2	--	--	--	--	--	--	--	--	--	--
110	3.9	8	--	--	0.522	4	5.032	3	--	--	0.1786	4
113	3.9	7	--	--	--	--	5.2	4	0.229	4	--	--
134	3.8	10	--	--	0.527	4	5.39	4	0.22	3	0.194	3
138	3.1	10	--	--	0.546	4	5.03	3	0.2	2	0.197	3
140	2.5	10	--	--	0.533	4	5.9	2	0.267	3	0.187	4
155	2.4	5	--	--	0.6563	0	--	--	--	--	--	--
180	3.6	10	--	--	0.582	3	5.48	4	0.263	3	<0.69	NR
183	2.0	3	--	--	--	--	10.12	0	0.26	3	--	--
190	3.6	10	--	--	0.5	3	5.25	4	0.238	4	0.2	3
193	3.8	5	--	--	0.516	4	--	--	--	--	0.174	3
203	2.7	8	--	--	0.4	0	--	--	--	--	0.18	4
204	3.5	2	--	--	--	--	--	--	--	--	--	--
208	4.0	2	--	--	--	--	5.2	4	--	--	--	--
215	1.6	8	5	4	3.1	0	--	--	0.3	1	--	--
220	1.6	8	5.109	3	0.409	0	2.397	0	--	--	0.108	0
243	4.0	2	--	--	--	--	--	--	--	--	--	--
247	2.9	11	4.1	4	0.547	4	4.76	2	0.2	2	0.234	0
255	3.5	4	--	--	0.588	3	--	--	<0.4	NR	--	--
256	0.5	7	--	--	--	--	6.53	0	0.14	0	<0.02	NR
265	3.0	6	--	--	0.52	4	4.85	2	--	--	0.19	4
268	2.5	8	--	--	0.583	3	4.48	1	--	--	0.242	0
270	0.4	5	--	--	13	0	--	--	--	--	14.66	0
273	2.0	11	18.86	0	0.52	4	5	3	0.29	1	0.15	0
274	0.8	11	4.11	4	0.79	0	24.41	0	0.07	0	0.1	0
277	2.0	2	--	--	--	--	--	--	--	--	--	--
279	1.1	7	--	--	0.53	4	8.1	0	--	--	1.21	0
287	2.3	9	--	--	0.619	2	5.02	3	0.3	1	0.178	4
301	1.3	3	--	--	--	--	6.3	0	--	--	--	--
315	2.2	6	--	--	0.48	2	5.44	4	--	--	0.25	0
321	2.9	8	--	--	0.49	3	4.8	2	--	--	--	--
328	1.1	11	3.6	4	0.7	0	6	1	0.33	0	<2.0	NR
333	3.3	9	0.58	1	0.55	4	5.54	3	--	--	0.18	4

Table 9. Laboratory performance ratings for standard reference sample P-35 (low-ionic strength constituents) --Continued

[MPV, most probable value; mg/L, milligrams per liter; Lab, laboratory number; OLR, overall laboratory rating for all reported values; V/11, number of reported values of 11 possible values; RV, reported value; --, not reported; <, less than; NR, not rated; $\mu\text{S}/\text{cm}$, microsiemens per centimeter.]

Rating	Absolute Z-value	Rating	Absolute Z-value
4 (Excellent)	0.00 - 0.50	1 (Marginal)	1.51 - 2.00
3 (Good)	0.51 - 1.00	0 (Unacceptable)	greater than 2.00
2 (Satisfactory)	1.01 - 1.50	NR (Not Rated)	

Lab	Analyte =	Specific conductance	
	MPV =	RV	Rating
	F-pseudostigma =	1.93	
1		25.7	3
2		29.9	2
23		27.2	4
25		30	1
38		--	--
45		25.7	3
48		24.3	2
59		26.7	4
64		29.3	2
81		25.9	3
86		28.7	3
89		442	0
93		21.32	0
105		25.8	3
107		28	3
110		26.05	4
113		26.6	4
134		27.26	4
138		28	3
140		29.8	2
155		25.8	3
180		27	4
183		--	--
190		26.1	4
193		27	4
203		28	3
204		26	3
208		--	--
215		24.9	2
220		--	--
243		27.9	4
247		27.4	4
255		--	--
256		--	--
265		--	--
268		28.4	3
270		--	--
273		29.6	2
274		27.1	4
277		25	2
279		26.6	4
287		26.1	4
301		15.3	0
315		--	--
321		24.2	2
328		30	1
333		28.9	3

Table 10. Laboratory performance ratings for standard reference sample Hg-31 (Mercury)

[MPV, most probable value; µg/L, micrograms per liter; mg/L, milligrams per liter; Lab, laboratory number; OLR, overall laboratory rating for all reported values; V/1, number of reported values of 1 possible value; RV, reported value; <, less than; NR, not rated; --, not reported.]

Rating	Absolute Z-value	Rating	Absolute Z-value
4 (Excellent)	0.00 - 0.50	1 (Marginal)	1.51 - 2.00
3 (Good)	0.51 - 1.00	0 (Unacceptable)	greater than 2.00
2 (Satisfactory)	1.01 - 1.50	NR (Not Rated)	

Analyte =			Mercury	
MPV =			0.498 µg/L	
F-pseudosigma =			0.035	
Lab	OLR	V/1	RV	Rating
1	4.0	1	0.499	4
10	4.0	1	0.5	4
12	0.0	1	0.28	0
13	1.0	1	0.43	1
18	0.0	1	0.593	0
45	4.0	1	0.51	4
48	0.0	1	0.4	0
50	3.0	1	0.471	3
55	4.0	1	0.5	4
59	3.0	1	0.47	3
69	NR	1	<0.50	NR
81	4.0	1	0.486	4
87	0.0	1	0.0004	0
89	4.0	1	0.49	4
96	0.0	1	0.593	0
97	3.0	1	0.48	3
105	3.0	1	0.527	3
107	2.0	1	0.54	2
118	0.0	1	0.39	0
127	4.0	1	0.496	4
134	4.0	1	0.502	4
138	3.0	1	0.471	3
142	3.0	1	0.47	3
144	3.0	1	0.52	3
147	2.0	1	0.452	2
198	3.0	1	0.473	3
203	4.0	1	0.51	4
212	2.0	1	0.54	2
213	0.0	1	0.6	0
215	1.0	1	0.56	1
220	0.0	1	0.41	0
234	4.0	1	0.506	4
247	4.0	1	0.49	4
265	2.0	1	0.46	2
277	4.0	1	0.51	4
298	4.0	1	0.514	4
304	4.0	1	0.498	4
307	3.0	1	0.469	3
321	0.0	1	44	0
328	0.0	1	0.62	0

Table 11. Statistical summary of reported data for standard reference samples T-163 (trace constituents)

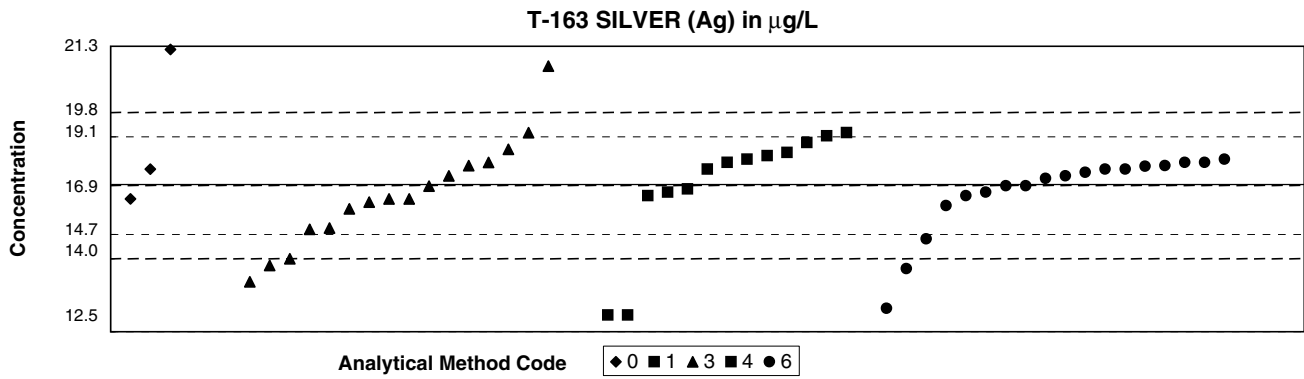

Summary	Methods					Statistics	
	0	1	3	4	6	Method Codes	
N =	3	1	17	15	18		
Minimum =	16.5	7.00	8.70	8.33	13.2	MPV =	16.9 µg/L
Maximum =	21.0		20.5	18.5	17.7	F-pseudosigma =	1.47
Median =			16.5	17.4	17.2	N =	54
F-pseudosigma =			1.42	2.26	0.652	Uh =	17.6
						Lh =	15.6

Lab	Rating	Z-value	Methods				
			0	1	3	4	6
1	4	0.40	--	--	--	--	17.5
12	0	-5.59	--	--	8.7	--	--
13	4	-0.07	--	--	--	16.8	--
18	4	0.15	--	--	--	--	17.1
23	4	-0.27	--	--	16.5	--	--
25	4	0.34	--	--	--	17.4	--
32	4	0.48	--	--	--	--	17.6
42	4	0.34	--	--	--	--	17.4
48	2	-1.09	--	--	--	--	15.3
50	4	-0.14	--	--	--	--	16.7
57	3	0.89	--	--	--	18.2	--
59	1	-1.70	--	--	--	--	14.4
69	4	-0.27	--	--	16.5	--	--
81	0	-2.66	--	--	--	13.0	--
86	3	0.55	--	--	--	17.7	--
87	4	-0.14	--	--	--	16.7	--
89	4	-0.48	--	--	16.2	--	--
96	4	0.20	--	--	17.2	--	--
97	2	-1.50	--	--	14.7	--	--
105	4	0.00	--	--	--	--	16.9
107	4	0.20	--	--	--	--	17.2
113	2	1.09	--	--	18.5	--	--
118	3	-0.87	--	--	15.6	--	--
127	0	2.45	--	--	20.5	--	--
134	4	-0.20	--	--	--	16.6	--
138	3	0.61	--	--	--	17.8	--
140	0	-6.74	--	7.0	--	--	--
142	4	0.00	--	--	--	--	16.9
144	4	0.48	--	--	17.6	--	--
180	NR	--	--	--	--	<3.72	--
190	1	-1.98	--	--	14.0	--	--
193	4	0.41	--	--	17.5	--	--
198	3	0.55	--	--	--	--	17.7
203	4	-0.34	--	--	16.4	--	--
204	0	-2.52	--	--	--	--	13.2
212	4	-0.41	--	--	--	--	16.3
215	3	0.75	--	--	18.0	--	--
220	4	-0.01	--	--	16.9	--	--
234	4	0.48	--	--	--	17.6	--
235	4	0.48	--	--	--	--	17.6
247	4	-0.20	--	--	--	--	16.6
255	4	0.41	--	--	--	--	17.5
256	0	2.79	21.0	--	--	--	--
257	NR	--	--	<20	--	--	--
265	4	0.34	--	--	--	--	17.4
270	0	-5.84	--	--	--	8.3	--
273	2	1.09	--	--	--	18.5	--
277	0	-3.88	--	--	--	11.2	--
297	2	1.02	--	--	--	18.4	--
304	4	0.34	17.4	--	--	--	--

Lab	Rating	Z-value	Methods				
			0	1	3	4	6
305	3	0.68	--	--	--	17.9	--
306	3	-0.89	--	--	15.6	--	--
307	1	-1.64	--	--	14.5	--	--
328	4	-0.27	16.5	--	--	--	--
331	0	-2.66	--	--	--	13.0	--
334	4	0.27	--	--	--	--	17.3

Table 11. Statistical summary of reported data for standard reference samples T-163 (trace constituents) -- Continued

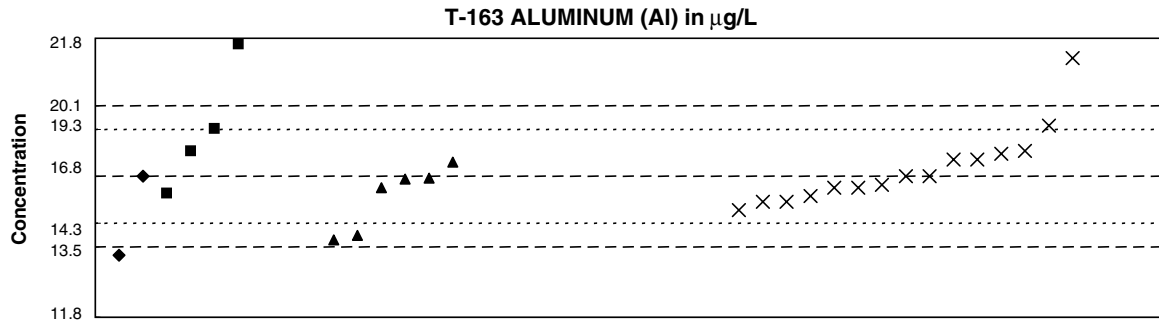

Analytical Method Code ◆ 0 ■ 3 ▲ 4 × 6

Summary	Methods				Statistics
	0	3	4	6	
N =	2	6	8	16	MPV = 16.8 µg/L
Minimum =	14.0	16.2	14.5	15.6	F-pseudostigma = 1.67
Maximum =	16.8	26.6	29.1	27.1	N = 32
Median =	20.0	16.7	16.8		Uh = 18.6
F-pseudostigma =	6.52	3.78	1.04		Lh = 16.3

Methods	Method Codes
0. Other	
3. Atomic absorption: graphite furnace	
4. Inductively coupled plasma	
6. Inductively coupled plasma/mass spectrometry	

Lab	Rating	Z-value	Methods			
			0	3	4	6
1	4	0.36	--	--	--	17.4
13	3	0.54	--	17.7	--	--
18	4	0.36	--	--	--	17.4
23	4	0.30	--	--	17.3	--
25	NR	--	--	--	<4.6	--
32	4	0.00	--	--	--	16.8
42	3	-0.54	--	--	--	15.9
48	0	2.52	--	--	--	21.0
50	4	0.00	--	--	--	16.8
57	0	7.37	--	--	29.1	--
59	3	-0.54	--	--	--	15.9
69	NR	--	--	<50	--	--
70	2	1.08	--	--	--	18.6
81	NR	--	--	--	<15	--
89	0	2.82	--	21.5	--	--
105	3	0.54	--	--	--	17.7
107	3	-0.72	--	--	--	15.6
110	2	-1.35	--	--	14.5	--
113	2	1.02	--	18.5	--	--
127	NR	--	--	--	<60	--
134	4	-0.04	--	--	16.7	--
138	2	-1.26	--	--	14.7	--
142	NR	--	--	--	<30	--
154	4	-0.24	--	--	16.4	--
180	NR	--	--	--	<23.8	--
190	4	-0.36	--	16.2	--	--
198	4	-0.24	--	--	--	16.4
203	NR	--	--	--	<14	--
204	4	0.48	--	--	--	17.6
212	0	6.18	--	--	--	27.1
234	4	-0.06	--	--	16.7	--
235	4	-0.24	--	--	--	16.4
247	4	-0.42	--	--	--	16.1
254	NR	--	--	--	<20	--
256	1	-1.68	14.0	--	--	--
265	4	-0.18	--	--	--	16.5
287	0	5.82	--	26.5	--	--
297	NR	--	--	--	<200	--
304	4	0.00	16.8	--	--	--
324	0	5.88	--	26.6	--	--
328	NR	--	--	--	<100	--
331	0	4.32	--	--	24.0	--

Table 11. Statistical summary of reported data for standard reference samples T-163 (trace constituents) -- Continued

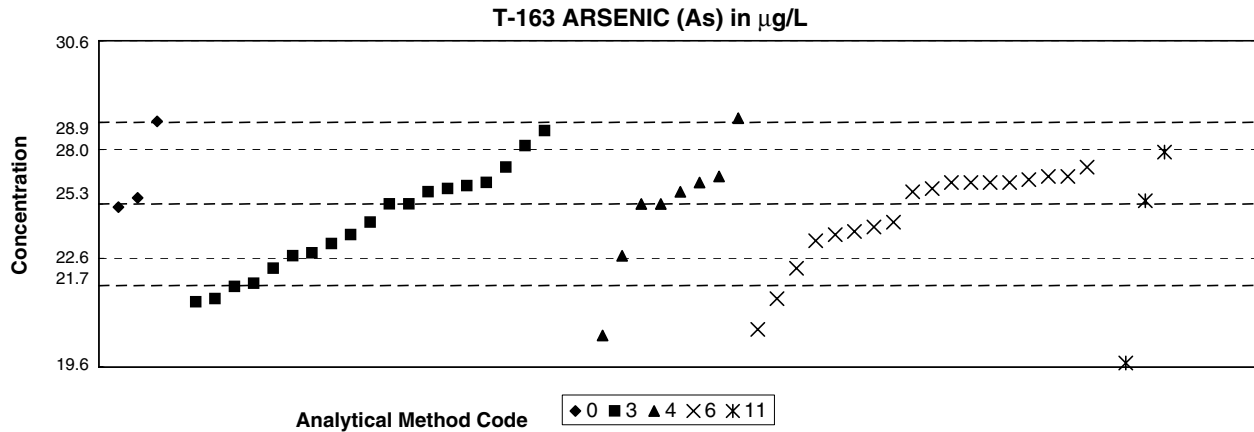

Summary	0	3	4	6	11	Methods	Method Codes	Statistics
N =	3	21	9	18	4	0. Other		MPV = 25.3 µg/L
Minimum =	25.2	19.0	17.7	21.2	16.3	3. Atomic absorption: graphite furnace		F-pseudostigma = 1.78
Maximum =	28.0	33.4	28.1	26.5	27.0	4. Inductively coupled plasma		N = 55
Median =	24.7	25.3	25.8			6. Inductively coupled plasma/mass spectrometry		Uh = 26.0
F-pseudostigma =	2.00	1.78	1.26			11. Atomic absorption: hydride		Lh = 23.6

Lab	Rating	Z-value	Methods				
			0	3	4	6	11
1	4	-0.42	--	--	--	24.6	--
10	2	1.35	--	27.7	--	--	--
12	1	-1.74	--	22.2	--	--	--
13	2	-1.46	--	22.7	--	--	--
18	4	0.28	--	--	--	25.8	--
23	4	0.22	--	--	25.7	--	--
25	0	-4.27	--	--	17.7	--	--
32	4	0.39	--	--	--	26.0	--
42	3	-0.67	--	--	--	24.1	--
45	4	0.22	--	25.7	--	--	--
48	4	-0.34	--	--	--	24.7	--
50	4	-0.51	--	--	--	24.4	--
57	4	0.00	--	--	25.3	--	--
59	3	0.67	--	--	--	26.5	--
69	3	-0.56	--	24.3	--	--	--
81	3	-0.73	--	24.0	--	--	--
86	0	-2.92	--	--	--	20.1	--
87	3	0.96	--	--	--	27.0	--
89	4	0.06	--	--	--	25.4	--
96	4	0.00	--	25.3	--	--	--
97	4	0.39	--	26.0	--	--	--
105	4	0.51	--	--	--	26.2	--
107	4	0.22	--	--	--	25.7	--
109	4	-0.34	--	24.7	--	--	--
113	4	0.34	--	25.9	--	--	--
118	0	4.55	--	33.4	--	--	--
127	2	-1.18	--	23.2	--	--	--
134	3	0.67	--	26.5	--	--	--
138	4	0.51	--	--	26.2	--	--
142	4	0.45	--	--	--	26.1	--
144	1	-1.52	--	22.6	--	--	--
147	4	0.11	25.5	--	--	--	--
154	3	-0.90	--	23.7	--	--	--
190	3	-0.96	--	23.6	--	--	--
193	4	0.00	--	25.3	--	--	--
198	2	-1.18	--	--	--	23.2	--
203	4	0.28	--	25.8	--	--	--
204	4	0.51	--	--	--	26.2	--
212	3	-0.56	--	--	--	24.3	--
215	0	-3.54	--	19.0	--	--	--
220	2	1.07	--	27.2	--	--	--
234	3	-0.96	--	--	23.6	--	--
247	0	-2.30	--	--	--	21.2	--
255	4	0.39	--	--	--	26.0	--
256	1	1.52	28.0	--	--	--	--
257	0	-5.06	--	--	--	16.3	--
265	4	0.39	--	--	--	26.0	--
277	4	0.39	--	--	--	26.0	--
297	4	0.00	--	--	--	25.3	--
304	4	-0.06	25.2	--	--	--	--

Lab	Rating	Z-value	Methods				
			0	3	4	6	11
305	1	1.57	--	--	28.1	--	--
307	1	-1.80	--	22.1	--	--	--
328	4	0.39	--	--	--	26.0	--
331	0	-2.42	--	--	21.0	--	--
334	1	-1.74	--	--	--	22.2	--

Table 11. Statistical summary of reported data for standard reference samples T-163 (trace constituents) -- Continued

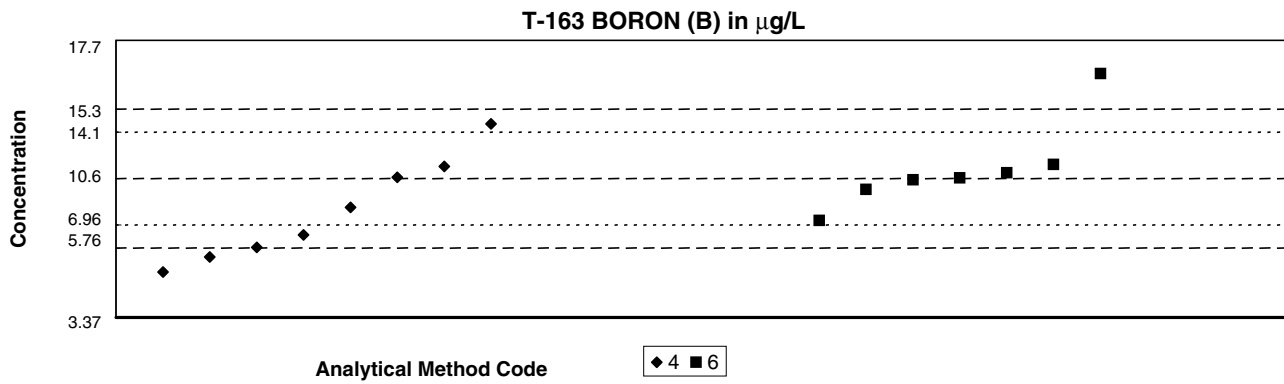

Summary	Methods		Method Codes	Statistics	
	4	6			
N =	9	7	4. Inductively coupled plasma	MPV =	10.6 $\mu\text{g/L}$
Minimum =	5.73	8.39	6. Inductively coupled plasma/mass spectrometry	F-pseudostigma =	2.39
Maximum =	69.4	16.0		N =	16
Median =	9.08	10.6		Uh =	11.3
F-pseudostigma =	3.11	0.619		Lh =	8.02

Lab	Rating	Z-value	Methods	
			4	6
1	NR	--	--	<12
25	NR	--	<2	--
32	4	0.02	--	10.6
42	3	-0.90	--	8.4
48	4	-0.02	--	10.5
57	2	1.19	13.4	--
105	NR	--	<200	--
127	NR	--	<8	--
134	4	0.04	10.6	--
138	4	0.27	11.2	--
142	NR	--	<30	--
180	0	24.58	69.4	--
212	4	0.31	--	11.3
234	3	-0.61	9.1	--
235	4	0.13	--	10.9
247	0	-2.01	5.7	--
255	2	-1.21	7.7	--
265	4	-0.23	--	10.0
273	1	-1.69	6.5	--
309	2	-1.48	7.0	--
328	0	2.28	--	16.0
331	NR	--	<80	--

Table 11. Statistical summary of reported data for standard reference samples T-163 (trace constituents) -- Continued

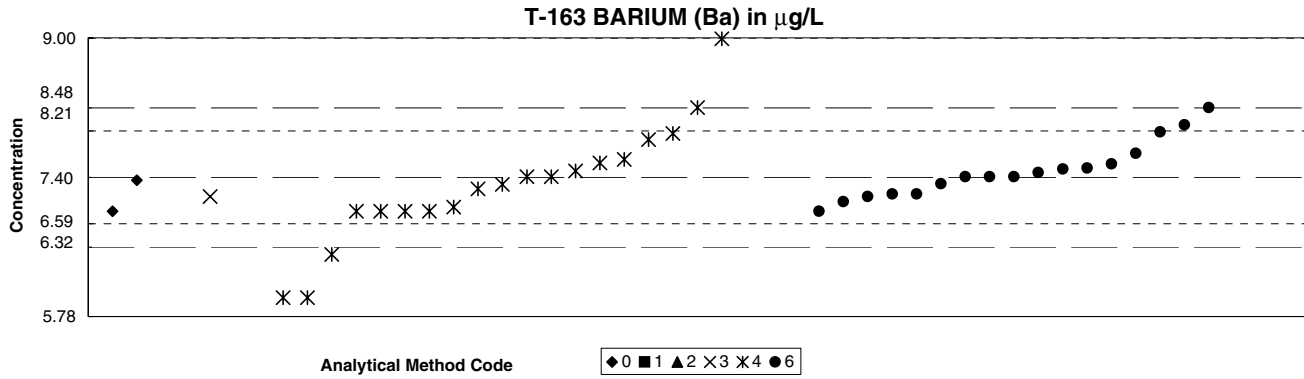

Summary	Methods						Method Codes	Statistics
	0	1	2	3	4	6		
N =	2	1	0	2	22	17	0. Other	MPV = 7.40 µg/L
Minimum =	7.00	10.0	<100	7.17	6.00	7.00	1. Atomic absorption: direct, air	F-pseudosigma = 0.537
Maximum =	7.36			10.0	39.5	8.20	2. Atomic absorption: direct, nitrous oxide	N = 44
Median =					7.40	7.40	3. Atomic absorption: graphite furnace	Uh = 7.87
F-pseudosigma =					0.667	0.259	4. Inductively coupled plasma	Lh = 7.14
							6. Inductively coupled plasma/mass spectrometry	

Lab	Rating	Z-value	Methods					
			0	1	2	3	4	6
1	4	0.17	--	--	--	--	--	7.49
13	1	-1.67	--	--	--	--	6.50	--
18	4	0.50	--	--	--	--	--	7.67
23	0	3.39	--	--	--	--	9.22	--
24	3	-0.74	--	--	--	--	7.00	--
25	0	-2.60	--	--	--	--	6.00	--
32	4	-0.37	--	--	--	--	--	7.20
42	3	-0.54	--	--	--	--	--	7.11
48	2	1.49	--	--	--	--	--	8.20
50	4	-0.37	--	--	--	--	--	7.20
57	4	0.37	--	--	--	--	7.60	--
59	2	1.12	--	--	--	--	--	8.00
70	3	0.97	--	--	--	--	--	7.92
81	0	-2.60	--	--	--	--	6.00	--
86	3	0.93	--	--	--	--	7.90	--
87	0	4.84	--	--	--	10.00	--	--
89	NR	--	--	--	--	<50	--	--
96	NR	--	--	--	<100	--	--	--
105	4	0.00	--	--	--	--	--	7.40
107	4	0.00	--	--	--	--	--	7.40
113	4	-0.43	--	--	--	7.17	--	--
121	3	-0.74	--	--	--	--	7.00	--
127	4	-0.17	--	--	--	--	7.31	--
134	4	0.12	--	--	--	--	7.47	--
138	4	-0.26	--	--	--	--	7.26	--
140	0	4.84	--	10.00	--	--	--	--
142	4	0.09	--	--	--	--	--	7.45
154	4	0.00	--	--	--	--	7.40	--
180	0	59.73	--	--	--	--	39.50	--
198	4	-0.43	--	--	--	--	--	7.17
203	0	3.35	--	--	--	--	9.20	--
204	4	0.28	--	--	--	--	--	7.55
212	3	-0.74	--	--	--	--	--	7.00
234	4	0.00	--	--	--	--	7.40	--
235	4	0.00	--	--	--	--	--	7.40
247	4	-0.15	--	--	--	--	--	7.32
256	3	-0.74	7.00	--	--	--	--	--
265	4	0.19	--	--	--	--	--	7.50
270	3	0.80	--	--	--	--	7.83	--
273	3	-0.74	--	--	--	--	7.00	--
297	4	0.30	--	--	--	--	--	7.56
304	4	-0.07	7.36	--	--	--	--	--
305	3	-0.65	--	--	--	--	7.05	--
309	0	2.98	--	--	--	--	9.00	--
328	2	1.49	--	--	--	--	8.20	--
331	3	-0.74	--	--	--	--	7.00	--

Table 11. Statistical summary of reported data for standard reference samples T-163 (trace constituents) -- Continued

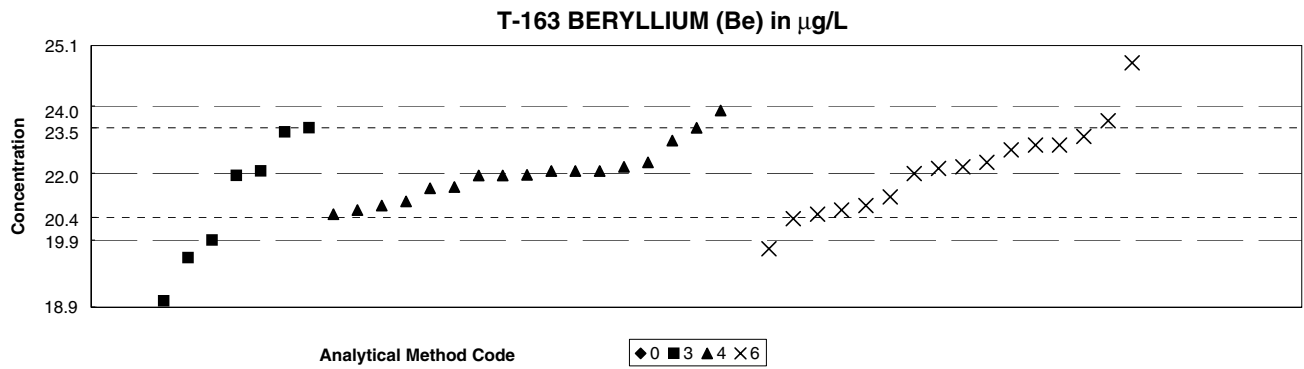

Summary	Methods				Method Codes	Statistics
	0	3	4	6		
N =	1	8	17	16	0. Other	MPV = 22.0 µg/L
Minimum =	25.0	18.8	21.0	20.2	3. Atomic absorption: graphite furnace	F-pseudostigma = 1.04
Maximum =		23.0	23.4	24.5	4. Inductively coupled plasma	Rating criterion= 1.10
Median =		21.2	21.9	22.1	6. Inductively coupled plasma/mass spectrometry	N = 42
F-pseudostigma =		2.19	0.371	1.07		Uh = 22.6
						Lh = 21.2

Lab	Rating	Z-value	Methods			
			0	3	4	6
1	2	1.08	--	--	--	23.2
13	4	0.03	--	--	22.0	--
18	4	0.47	--	--	--	22.5
23	3	-0.61	--	--	21.3	--
25	4	-0.34	--	--	21.6	--
32	3	0.57	--	--	--	22.6
42	3	-0.52	--	--	--	21.4
48	3	-0.88	--	--	--	21.0
50	3	-0.79	--	--	--	21.1
57	3	-0.70	--	--	21.2	--
59	3	0.76	--	--	--	22.8
69	4	0.03	--	22.0	--	--
70	0	2.30	--	--	--	24.5
76	4	0.08	--	--	--	22.1
81	0	-2.89	--	18.8	--	--
86	4	0.12	--	--	22.1	--
89	4	-0.06	--	21.9	--	--
96	2	-1.43	--	20.4	--	--
97	0	-2.70	--	19.0	--	--
105	4	0.03	--	--	22.0	--
113	3	0.85	--	22.9	--	--
127	2	1.30	--	--	23.4	--
134	4	-0.31	--	--	21.6	--
138	3	-0.79	--	--	21.1	--
142	3	-0.70	--	--	--	21.2
144	1	-1.79	--	20.0	--	--
154	4	0.03	--	--	22.0	--
180	NR	--	--	--	<0.6	--
193	3	0.94	--	23.0	--	--
198	3	0.57	--	--	--	22.6
204	4	0.12	--	--	--	22.1
212	3	-0.97	--	--	--	20.9
215	3	0.94	--	--	23.0	--
220	4	-0.05	--	--	21.9	--
234	4	-0.06	--	--	21.9	--
235	4	-0.03	--	--	--	21.9
247	1	-1.61	--	--	--	20.2
256	0	2.76	25.0	--	--	--
265	4	-0.06	--	--	21.9	--
297	4	0.21	--	--	22.2	--
305	3	0.66	--	--	22.7	--
328	4	0.21	--	--	--	22.2
331	3	-0.88	--	--	21.0	--

Table 11. Statistical summary of reported data for standard reference samples T-163 (trace constituents) -- Continued

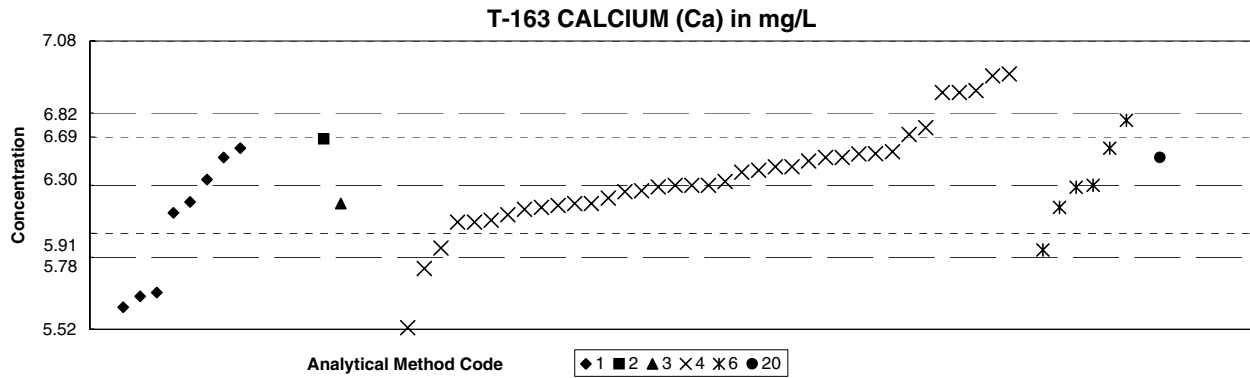

Summary		Methods						Statistics	
		1	2	3	4	6	20	Method Codes	
N =	12	2	1	41	6	2		1. Atomic absorption: direct, air	MPV = 6.30 mg/L
Minimum =	4.09	4.62	6.20	4.47	5.95	5.51		2. Atomic absorption: direct, nitrous oxide	F-pseudosigma = 0.259
Maximum =	32.0	6.55		30.0	6.65	6.45		3. Atomic absorption: graphite furnace	Rating criterion= 0.315
Median =	6.27			6.30	6.29			4. Inductively coupled plasma	N = 64
F-pseudosigma =	0.956		0.221	0.237				6. Inductively coupled plasma/mass spectrometry	Uh = 6.48
								20. Titration: colorimetric	Lh = 6.13

Lab	Rating	Z-value	Methods					
			1	2	3	4	6	20
1	3	0.53	--	--	--	6.47	--	--
12	4	0.00	--	--	--	6.30	--	--
13	4	0.00	--	--	--	6.30	--	--
23	4	-0.29	6.21	--	--	--	--	--
24	3	-0.63	--	--	--	6.10	--	--
25	0	-2.92	--	--	--	5.38	--	--
32	4	0.00	--	--	--	--	6.30	--
42	4	0.25	--	--	--	6.38	--	--
45	4	0.10	6.33	--	--	--	--	--
48	2	1.11	--	--	--	--	6.65	--
50	4	-0.38	--	--	--	--	6.18	--
57	4	-0.41	--	--	--	6.17	--	--
59	3	0.63	--	--	--	--	6.50	--
64	4	-0.35	--	--	--	6.19	--	--
69	1	-1.84	5.72	--	--	--	--	--
70	3	0.98	--	--	--	6.61	--	--
76	4	-0.04	--	--	--	--	6.29	--
81	4	0.22	--	--	--	6.37	--	--
86	3	0.54	--	--	--	6.47	--	--
87	0	-5.33	--	4.62	--	--	--	--
89	0	-7.02	4.09	--	--	--	--	--
97	4	-0.48	6.15	--	--	--	--	--
105	4	-0.22	--	--	--	6.23	--	--
107	0	3.81	7.50	--	--	--	--	--
109	3	0.63	6.50	--	--	--	--	--
110	4	0.48	--	--	--	6.45	--	--
113	4	-0.32	--	--	6.20	--	--	--
121	4	0.41	--	--	--	6.43	--	--
127	2	-1.43	--	--	--	5.85	--	--
134	4	-0.11	--	--	--	6.27	--	--
138	3	-0.60	--	--	--	6.11	--	--
140	1	-1.90	5.70	--	--	--	--	--
142	1	1.62	--	--	--	6.81	--	--
154	3	-0.63	--	--	--	6.10	--	--
180	0	75.24	--	--	--	30.00	--	--
190	4	0.48	6.45	--	--	--	--	--
193	4	-0.38	--	--	--	6.18	--	--
198	0	-2.44	--	--	--	5.53	--	--
203	4	0.00	--	--	--	6.30	--	--
204	3	0.57	--	--	--	6.48	--	--
212	2	-1.11	--	--	--	--	5.95	--
215	1	1.59	--	--	--	6.80	--	--
220	3	0.87	--	--	--	6.57	--	--
234	4	-0.03	--	--	--	6.29	--	--
235	4	-0.51	--	--	--	6.14	--	--
247	4	-0.10	--	--	--	6.27	--	--
254	4	0.48	--	--	--	6.45	--	--
255	4	0.06	--	--	--	6.32	--	--
261	0	81.59	32.00	--	--	--	--	--
265	4	-0.32	--	--	--	6.20	--	--

Lab	Rating	Z-value	Methods					
			1	2	3	4	6	20
268	0	-2.10	5.64	--	--	--	--	--
270	0	-3.56	--	--	--	5.18	--	--
273	4	0.32	--	--	--	6.40	--	--
274	0	-2.51	--	--	--	--	--	5.51
277	4	0.32	--	--	--	6.40	--	--
279	4	0.48	--	--	--	--	--	6.45
287	3	0.79	--	6.55	--	--	--	--
297	0	-5.81	--	--	--	4.47	--	--
305	2	-1.08	--	--	--	5.96	--	--
309	1	1.90	--	--	--	6.90	--	--
315	4	-0.32	--	--	--	6.20	--	--
324	0	8.76	9.06	--	--	--	--	--
328	1	1.59	--	--	--	6.80	--	--
331	1	1.87	--	--	--	6.89	--	--

Table 11. Statistical summary of reported data for standard reference samples T-163 (trace constituents) -- Continued

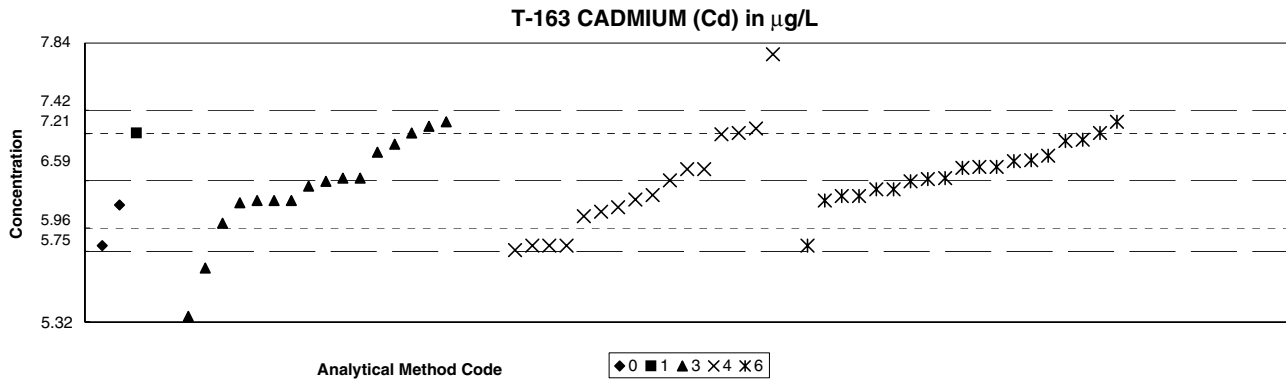

Summary	Methods					Statistics
	0	1	3	4	6	
N =	2	2	19	17	20	MPV = 6.59 µg/L
Minimum =	6.00	7.00	4.00	4.80	6.00	F-pseudostigma = 0.419
Maximum =	6.36	8.00	9.25	7.70	7.20	N = 60
Median =			6.57	6.41	6.70	Uh = 6.94
F-pseudostigma =			0.415	0.504	0.271	Lh = 6.37

Lab	Rating	Z-value	Methods				
			0	1	3	4	6
1	4	0.42	--	--	--	--	6.76
10	4	-0.44	--	--	6.40	--	--
12	0	-6.17	--	--	4.00	--	--
13	3	-0.68	--	--	--	6.30	--
18	4	0.01	--	--	--	--	6.59
23	3	-0.78	--	--	--	6.26	--
25	2	-1.40	--	--	--	6.00	--
32	4	0.27	--	--	--	--	6.70
42	4	-0.35	--	--	--	--	6.44
48	4	-0.20	--	--	--	--	6.50
50	4	-0.44	--	--	--	--	6.40
57	2	-1.49	--	--	--	5.96	--
59	2	1.23	--	--	--	--	7.10
69	3	-0.92	--	--	6.20	--	--
70	4	0.39	--	--	--	--	6.75
76	4	0.04	--	--	--	--	6.60
81	3	0.99	--	--	7.00	--	--
86	0	2.66	--	--	--	7.70	--
87	0	-4.26	--	--	--	4.80	--
89	2	1.13	--	--	7.06	--	--
96	4	-0.13	--	--	6.53	--	--
97	1	-1.87	--	--	5.80	--	--
105	4	-0.20	--	--	--	--	6.50
107	3	0.99	--	--	--	--	7.00
113	4	0.04	--	--	6.60	--	--
118	0	3.02	--	--	7.85	--	--
121	3	0.99	--	--	--	7.00	--
127	4	-0.49	--	--	6.38	--	--
134	4	0.23	--	--	--	6.68	--
138	4	-0.42	--	--	--	6.41	--
140	3	0.99	--	7.00	--	--	--
142	3	0.85	--	--	--	--	6.94
144	2	1.23	--	--	7.10	--	--
147	4	0.27	--	--	--	--	6.70
154	0	-2.90	--	--	5.37	--	--
180	NR	--	--	--	--	<3.78	--
190	3	0.58	--	--	6.83	--	--
193	4	-0.44	--	--	6.40	--	--
198	4	-0.35	--	--	--	--	6.44
203	4	0.04	--	--	6.60	--	--
204	4	-0.04	--	--	--	--	6.57
212	2	-1.40	--	--	--	--	6.00
215	3	0.75	--	--	6.90	--	--
220	4	-0.44	--	--	6.40	--	--
234	4	-0.01	--	--	--	6.58	--
235	4	0.25	--	--	--	--	6.69
247	3	-0.58	--	--	6.34	--	--
255	3	0.82	--	--	--	--	6.93
256	2	-1.40	6.00	--	--	--	--
257	0	3.38	--	8.00	--	--	--

Lab	Rating	Z-value	Methods				
			0	1	3	4	6
265	3	0.51	--	--	--	--	6.80
270	3	0.97	--	--	--	6.99	--
273	2	-1.40	--	--	--	6.00	--
274	4	-0.04	--	--	6.57	--	--
277	4	-0.32	--	--	--	6.45	--
297	4	0.23	--	--	--	6.68	--
304	3	-0.54	6.36	--	--	--	--
305	2	1.09	--	--	--	7.04	--
307	0	6.36	--	--	9.25	--	--
328	2	1.47	--	--	--	--	7.20
331	2	-1.40	--	--	--	6.00	--

Table 11. Statistical summary of reported data for standard reference samples T-163 (trace constituents) -- Continued

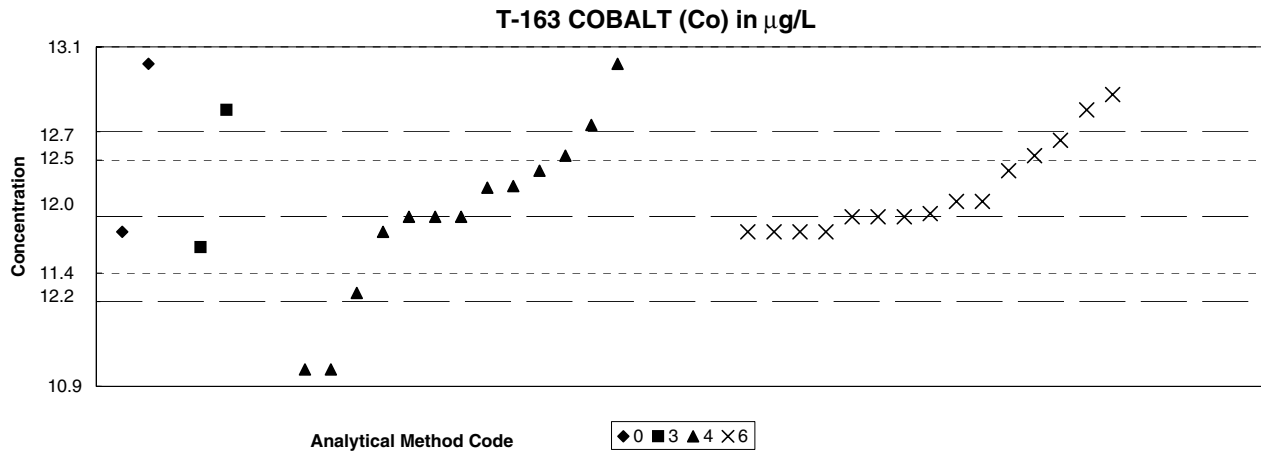

Summary	Methods				Statistics
	0	3	4	6	
N =	2	3	17	15	MPV = 12.0 µg/L
Minimum =	11.9	10.8	9.0	11.9	F-pseudosigma = 0.371
Maximum =	13.0	12.7	18.0	12.8	Rating criterion = 0.600
Median =			12.0	12.0	N = 37
F-pseudosigma =			0.667	0.297	Uh = 12.4
					Lh = 11.9

Lab	Rating	Z-value	Methods			
			0	3	4	6
1	2	1.33	--	--	--	12.8
13	NR	--	--	--	<50	--
18	3	0.67	--	--	--	12.4
24	4	0.00	--	--	12.0	--
25	0	-2.83	--	--	10.3	--
32	3	0.83	--	--	--	12.5
42	4	0.17	--	--	--	12.1
48	4	0.17	--	--	--	12.1
50	4	-0.17	--	--	--	11.9
57	4	0.00	--	--	12.0	--
70	2	1.17	--	--	--	12.7
76	4	0.03	--	--	--	12.0
81	1	-1.67	--	--	11.0	--
86	0	-5.00	--	--	9.0	--
89	1	-2.00	--	10.8	--	--
96	2	1.17	--	12.7	--	--
105	4	-0.17	--	--	--	11.9
121	1	-1.67	--	--	11.0	--
127	4	-0.33	--	11.8	--	--
134	4	0.32	--	--	12.2	--
138	4	-0.17	--	--	11.9	--
142	4	-0.17	--	--	--	11.9
154	4	0.33	--	--	12.2	--
180	NR	--	--	--	<3.98	--
198	4	0.50	--	--	--	12.3
212	4	0.00	--	--	--	12.0
234	3	0.67	--	--	12.4	--
235	4	-0.17	--	--	--	11.9
247	4	0.00	--	--	--	12.0
254	0	2.17	--	--	13.3	--
256	1	1.67	13.0	--	--	--
265	4	0.00	--	--	--	12.0
270	1	1.67	--	--	13.0	--
273	3	-0.83	--	--	11.5	--
277	4	0.50	--	--	12.3	--
297	3	1.00	--	--	12.6	--
304	4	-0.17	11.9	--	--	--
328	0	10.00	--	--	18.0	--
331	4	0.00	--	--	12.0	--

Table 11. Statistical summary of reported data for standard reference samples T-163 (trace constituents) -- Continued

T-163 CHROMIUM (Cr) in µg/L

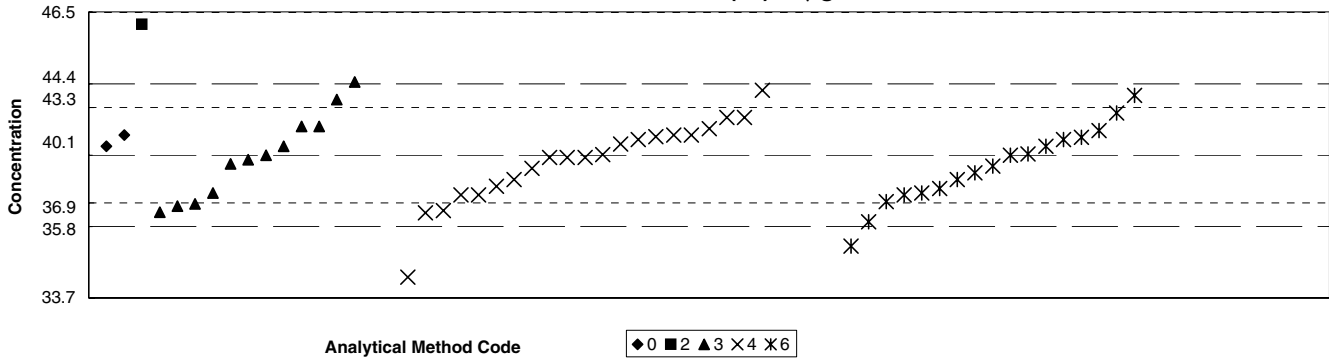

Summary	Methods					Statistics
	0	2	3	4	6	
N =	2	1	13	25	17	MPV = 40.1 µg/L
Minimum =	40.5	46.0	37.5	32.6	36.0	F-pseudostigma = 2.15
Maximum =	41.0		52.0	53.0	42.8	N = 58
Median =			40.1	40.1	39.6	Uh = 41.3
F-pseudostigma =			2.22	1.93	1.78	Lh = 38.4

Methods	
Method Codes	
0.	Other
2.	Atomic absorption: direct, nitrous oxide
3.	Atomic absorption: graphite furnace
4.	Inductively coupled plasma
6.	Inductively coupled plasma/mass spectrometry

Lab	Rating	Z-value	Methods				
			0	2	3	4	6
1	4	0.38	--	--	--	40.9	--
10	4	-0.01	--	--	40.1	--	--
12	0	4.13	--	--	--	49.0	--
13	4	0.32	--	--	--	40.8	--
18	4	0.32	--	--	--	--	40.8
23	2	-1.17	--	--	--	37.6	--
24	3	-0.52	--	--	--	39.0	--
25	0	3.62	--	--	--	47.9	--
32	4	0.18	--	--	--	--	40.5
42	4	0.37	--	--	--	--	40.9
48	3	-0.52	--	--	--	--	39.0
50	4	-0.38	--	--	--	--	39.3
57	0	-2.57	--	--	--	34.6	--
59	3	-0.84	--	--	--	--	38.3
69	3	0.60	--	--	41.4	--	--
70	3	0.88	--	--	--	--	42.0
76	4	0.02	--	--	--	--	40.2
81	0	5.53	--	--	52.0	--	--
86	4	0.41	--	--	--	41.0	--
87	3	0.78	--	--	--	41.8	--
89	1	1.53	--	--	43.4	--	--
96	2	-1.03	--	--	37.9	--	--
97	2	1.16	--	--	42.6	--	--
105	4	-0.24	--	--	--	--	39.6
107	2	-1.40	--	--	--	--	37.1
113	4	-0.19	--	--	39.7	--	--
121	1	-1.91	--	--	--	--	36.0
127	3	0.78	--	--	--	41.8	--
134	4	0.01	--	--	--	40.1	--
138	2	-1.22	--	--	--	37.5	--
140	0	2.74	--	46.0	--	--	--
142	3	-0.70	--	--	--	--	38.6
144	3	-0.80	--	--	38.4	--	--
154	4	-0.29	--	--	--	39.5	--
180	NR	--	--	--	--	<4.5	--
190	2	-1.08	--	--	37.8	--	--
193	3	0.60	--	--	41.4	--	--
198	3	-0.98	--	--	--	--	38.0
203	4	-0.10	--	--	39.9	--	--
204	4	0.50	--	--	--	--	41.2
212	4	-0.01	--	--	--	--	40.1
215	4	0.41	--	--	--	41.0	--
220	2	1.36	--	--	--	43.0	--
234	4	0.23	--	--	--	40.6	--
235	3	-0.66	--	--	--	38.7	--
247	3	-0.80	--	--	--	--	38.4
255	2	1.25	--	--	--	--	42.8
256	4	0.41	41.0	--	--	--	--
265	4	-0.05	--	--	--	40.0	--
270	0	-3.50	--	--	--	32.6	--

Lab	Rating	Z-value	Methods				
			0	2	3	4	6
273	4	-0.05	--	--	--	40.0	--
277	3	-0.84	--	--	--	38.3	--
297	3	-0.84	--	--	--	38.3	--
304	4	0.18	40.5	--	--	--	--
305	3	0.55	--	--	--	41.3	--
306	2	-1.20	--	--	37.5	--	--
307	4	0.18	--	--	40.5	--	--
328	0	5.99	--	--	--	53.0	--
331	4	-0.05	--	--	--	40.0	--

Table 11. Statistical summary of reported data for standard reference samples T-163 (trace constituents) -- Continued

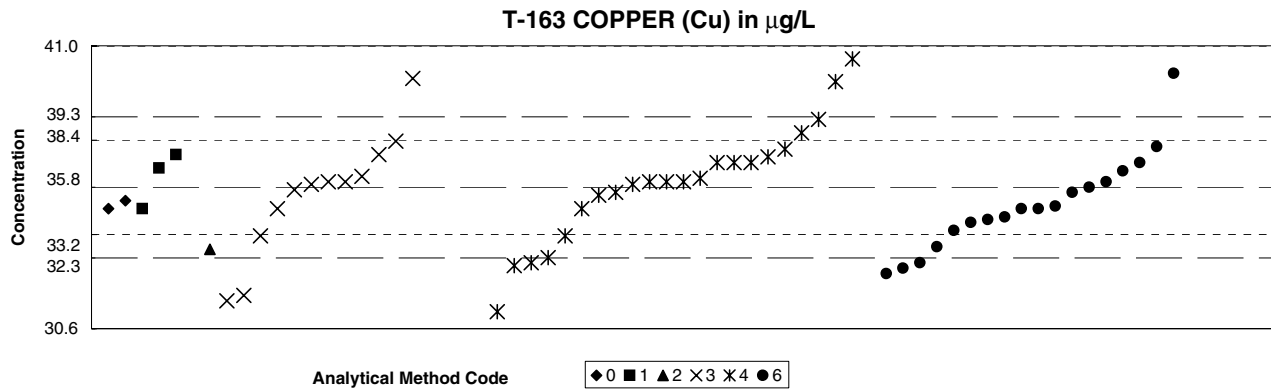

Summary	Methods						Statistics
	0	1	2	3	4	6	
N =	2	3	1	14	25	18	MPV = 35.8 µg/L
Minimum =	35.0	35.0	33.5	31.6	32.3	32.6	F-pseudostandard = 1.74
Maximum =	35.3	37.0		57.0	45.0	40.0	Rating criterion = 1.79
Median =				36.0	36.0	35.0	N = 63
F-pseudostandard =				1.85	2.16	1.33	Uh = 36.7
	Methods Method Codes 0. Other 1. Atomic absorption: direct, air 2. Atomic absorption: direct, nitrous oxide 3. Atomic absorption: graphite furnace 4. Inductively coupled plasma 6. Inductively coupled plasma/mass spectrometry						Lh = 34.4

Lab	Rating	Z-value	Methods					
			0	1	2	3	4	6
1	3	0.63	--	--	--	--	36.9	--
10	4	0.11	--	--	--	36.0	--	--
12	4	-0.06	--	--	--	35.7	--	--
13	0	-2.57	--	--	--	--	31.2	--
18	0	2.35	--	--	--	--	--	40.0
23	2	-1.45	--	--	--	--	33.2	--
24	4	-0.45	--	--	--	35.0	--	--
25	0	2.18	--	--	--	--	39.7	--
32	4	0.11	--	--	--	--	--	36.0
42	4	0.00	--	--	--	--	--	35.8
45	4	0.39	--	36.5	--	--	--	--
48	4	-0.45	--	--	--	--	--	35.0
50	3	-0.73	--	--	--	--	--	34.5
57	3	0.78	--	--	--	--	37.2	--
59	3	-0.89	--	--	--	--	--	34.2
69	NR	--	--	<50	--	--	--	--
70	4	0.50	--	--	--	--	--	36.7
81	3	0.67	--	--	--	37.0	--	--
86	4	-0.11	--	--	--	--	35.6	--
87	2	1.40	--	--	--	--	38.3	--
89	3	-1.01	--	--	--	34.0	--	--
96	4	0.11	--	--	--	36.0	--	--
105	4	0.11	--	--	--	--	36.0	--
107	1	-1.79	--	--	--	--	--	32.6
113	4	0.22	--	--	--	36.2	--	--
118	0	5.20	--	--	--	45.1	--	--
121	1	-1.56	--	--	--	--	--	33.0
127	1	-1.62	--	--	--	--	32.9	--
134	4	0.06	--	--	--	--	35.9	--
138	4	-0.17	--	--	--	--	35.5	--
140	3	0.67	--	37.0	--	--	--	--
142	2	-1.23	--	--	--	--	--	33.6
144	0	-2.35	--	--	--	31.6	--	--
147	4	-0.28	35.3	--	--	--	--	--
154	4	-0.45	--	--	--	--	35.0	--
180	0	-18.20	--	--	--	--	3.2	--
190	3	0.95	--	--	--	37.5	--	--
193	4	0.06	--	--	--	35.9	--	--
198	1	-1.68	--	--	--	--	--	32.8
203	4	0.11	--	--	--	--	36.0	--
204	3	0.84	--	--	--	--	--	37.3
212	3	-0.61	--	--	--	--	--	34.7
215	0	5.14	--	--	--	--	45.0	--
220	4	0.18	--	--	--	--	--	36.1
234	4	0.50	--	--	--	--	--	36.7
235	4	-0.39	--	--	--	--	--	35.1
247	3	-0.67	--	--	--	--	--	34.6
254	4	0.50	--	--	--	--	36.7	--
255	4	0.34	--	--	--	--	--	36.4
257	4	-0.45	--	35.0	--	--	--	--

Lab	Rating	Z-value	Methods					
			0	1	2	3	4	6
265	4	0.11	--	--	--	--	36.0	--
270	0	2.65	--	--	--	--	40.5	--
273	0	-7.93	--	--	--	--	--	21.6
274	0	2.24	--	--	--	39.8	--	--
277	1	-1.56	--	--	--	--	--	33.0
287	2	-1.28	--	--	33.5	--	--	--
297	2	1.12	--	--	--	--	--	37.8
304	4	-0.45	35.0	--	--	--	--	--
305	4	0.50	--	--	--	--	--	36.7
306	0	11.83	--	--	--	57.0	--	--
307	0	-2.23	--	--	--	31.8	--	--
328	4	-0.45	--	--	--	--	--	35.0
331	3	-1.01	--	--	--	--	34.0	--
334	4	-0.11	--	--	--	--	--	35.6

Table 11. Statistical summary of reported data for standard reference samples T-163 (trace constituents) -- Continued

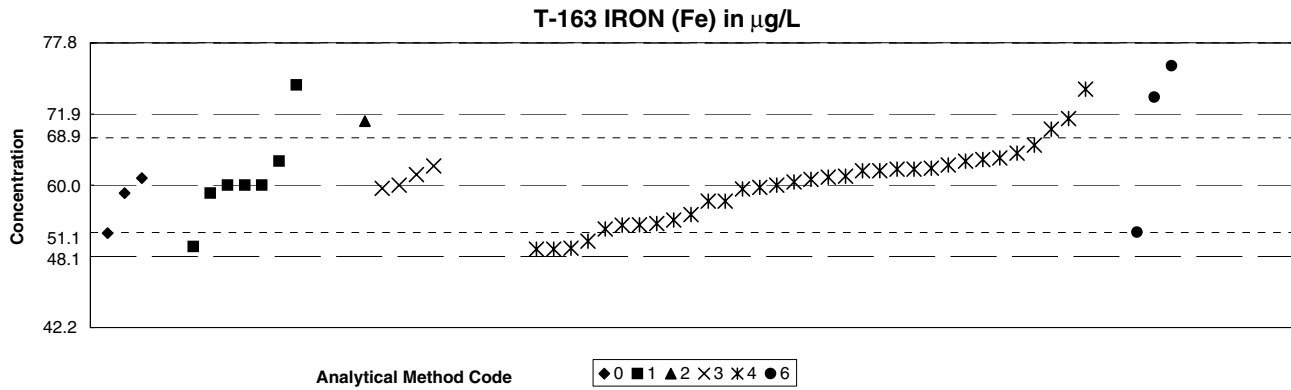

Summary	Methods						Statistics
	0	1	2	3	4	6	
N =	3	11	1	4	39	3	MPV = 60.0 µg/L
Minimum =	54.0	5.60	68.0	59.6	0.022	54.1	F-pseudosigma = 5.93
Maximum =	60.9	98.0	62.4	78.0	74.9		N = 61
Median =	60.0			60.0			Uh = 63.0
F-pseudosigma =	8.96			5.60			Lh = 55.0
	Method Codes						
	0. Other						
	1. Atomic absorption: direct, air						
	2. Atomic absorption: direct, nitrous oxide						
	3. Atomic absorption: graphite furnace						
	4. Inductively coupled plasma						
	6. Inductively coupled plasma/mass spectrometry						

Lab	Rating	Z-value	Methods					
			0	1	2	3	4	6
1	3	0.54	--	--	--	--	63.2	--
10	4	0.51	--	63.0	--	--	--	--
12	3	0.67	--	--	--	--	64.0	--
13	3	-0.62	--	--	--	--	56.3	--
21	4	0.15	60.9	--	--	--	--	--
23	4	0.00	--	--	--	--	60.0	--
24	4	0.17	--	--	--	--	61.0	--
25	4	0.42	--	--	--	--	62.5	--
42	4	0.19	--	--	--	--	61.1	--
45	0	2.11	--	72.5	--	--	--	--
48	1	1.85	--	--	--	--	--	71.0
50	3	-0.99	--	--	--	--	--	54.1
57	4	-0.08	--	--	--	--	59.5	--
64	0	-5.65	--	--	--	--	26.5	--
69	NR	--	--	<50	--	--	--	--
70	0	-3.71	--	--	--	--	38.0	--
81	0	-3.04	--	--	--	--	42.0	--
87	4	0.07	--	--	--	--	60.4	--
89	4	0.00	--	--	--	60.0	--	--
96	4	0.00	--	60.0	--	--	--	--
105	2	1.18	--	--	--	--	67.0	--
107	4	0.00	--	60.0	--	--	--	--
109	2	-1.29	--	52.3	--	--	--	--
113	4	-0.07	--	--	--	59.6	--	--
118	0	6.41	--	98.0	--	--	--	--
121	4	-0.34	--	--	--	--	58.0	--
127	4	0.30	--	--	--	--	61.8	--
134	4	-0.34	--	--	--	--	58.0	--
138	3	-0.81	--	--	--	--	55.2	--
140	4	0.00	--	60.0	--	--	--	--
142	4	0.34	--	--	--	--	62.0	--
147	4	-0.17	59.0	--	--	--	--	--
154	4	0.35	--	--	--	--	62.1	--
180	NR	--	--	--	--	--	<3.81	--
190	4	0.40	--	--	--	62.4	--	--
193	4	-0.17	--	59.0	--	--	--	--
198	4	0.12	--	--	--	--	60.7	--
203	3	-0.84	--	--	--	--	55.0	--
204	2	-1.35	--	--	--	--	52.0	--
212	0	2.51	--	--	--	--	--	74.9
215	0	2.02	--	--	--	--	72.0	--
220	3	-0.74	--	--	--	--	55.6	--
234	3	0.57	--	--	--	--	63.4	--
235	4	-0.05	--	--	--	--	59.7	--
247	3	-0.84	--	--	--	--	55.0	--
254	4	0.30	--	--	--	--	61.8	--
255	3	-0.93	--	--	--	--	54.5	--
256	2	-1.01	54.0	--	--	--	--	--
261	0	-6.75	--	20.0	--	--	--	--
265	3	0.84	--	--	--	--	65.0	--

Lab	Rating	Z-value	Methods					
			0	1	2	3	4	6
270	0	-3.23	--	--	--	--	40.9	--
273	4	0.51	--	--	--	--	63.0	--
274	4	0.22	--	--	--	61.3	--	--
277	2	-1.33	--	--	--	--	52.1	--
287	2	1.35	--	--	68.0	--	--	--
297	2	1.40	--	--	--	--	68.3	--
305	2	-1.35	--	--	--	--	52.0	--
307	0	-9.17	--	5.6	--	--	--	--
315	0	-10.11	--	--	--	--	0.0	--
324	0	5.83	--	94.6	--	--	--	--
328	2	-1.18	--	--	--	--	53.0	--
331	4	0.34	--	--	--	--	62.0	--
334	0	3.04	--	--	--	--	78.0	--

Table 11. Statistical summary of reported data for standard reference samples T-163 (trace constituents) -- Continued

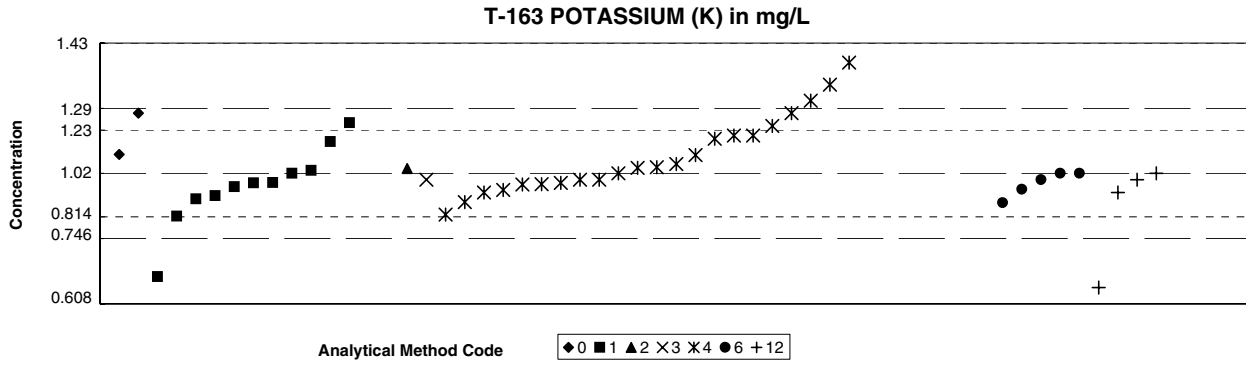

Summary	Methods							Method Codes	Statistics
	0	1	2	3	4	6	12		
N =	2	13	1	1	27	5	4	0. Other	MPV = 1.02 mg/L
Minimum =	1.08	0.694	1.04	1.00	0.890	0.928	0.660	1. Atomic absorption: direct, air	F-pseudosigma = 0.137
Maximum =	1.21	944			4.00	1.02	1.02	2. Atomic absorption: direct, nitrous oxide	N = 53
Median =		0.991			1.08	1.00		3. Atomic absorption: graphite furnace	Uh = 1.17
F-pseudosigma =		0.126			0.208	0.037		4. Inductively coupled plasma	Lh = 0.985
								6. Inductively coupled plasma/mass spectrometry	
								12. Flame emission	

Lab	Rating	Z-value	Methods						
			0	1	2	3	4	6	12
1	4	0.00	--	1.02	--	--	--	--	--
13	4	-0.22	--	--	--	--	0.99	--	--
23	3	-0.58	--	0.94	--	--	--	--	--
24	4	-0.44	--	--	--	--	0.96	--	--
25	4	0.42	--	--	--	--	1.08	--	--
32	4	0.00	--	--	--	--	--	1.02	--
42	4	-0.25	--	--	--	--	0.99	--	--
45	0	-2.38	--	0.69	--	--	--	--	--
48	4	-0.36	--	--	--	--	--	0.97	--
50	3	-0.67	--	--	--	--	--	0.93	--
57	0	3.35	--	--	--	--	1.48	--	--
59	4	-0.15	--	--	--	--	--	1.00	--
64	4	-0.22	--	0.99	--	--	--	--	--
69	4	-0.15	--	--	--	--	--	--	1.00
70	4	0.15	--	--	--	--	1.04	--	--
81	2	1.09	--	--	--	--	1.17	--	--
86	4	-0.15	--	--	--	--	1.00	--	--
87	0	6876	--	944	--	--	--	--	--
89	3	-0.98	--	0.89	--	--	--	--	--
105	NR	--	--	--	--	--	<1.00	--	--
107	2	1.17	--	1.18	--	--	--	--	--
109	3	0.73	--	1.12	--	--	--	--	--
110	4	0.44	1.08	--	--	--	--	--	--
113	4	-0.15	--	--	--	1.00	--	--	--
127	4	0.07	--	1.03	--	--	--	--	--
134	4	-0.31	--	0.98	--	--	--	--	--
138	4	-0.38	--	--	--	--	0.97	--	--
140	3	-0.51	--	0.95	--	--	--	--	--
142	NR	--	--	--	--	--	<1	--	--
180	0	8.53	--	--	--	--	2.19	--	--
193	4	-0.21	--	0.99	--	--	--	--	--
198	3	-0.95	--	--	--	--	0.89	--	--
203	4	0.00	--	--	--	--	--	--	1.02
204	3	0.88	--	--	--	--	1.14	--	--
212	4	0.00	--	--	--	--	--	1.02	--
220	4	0.13	--	--	--	--	1.04	--	--
234	4	0.00	--	--	--	--	--	1.02	--
235	4	-0.26	--	--	--	--	0.99	--	--
247	4	-0.15	--	--	--	--	1.00	--	--
254	2	1.39	--	--	--	--	--	1.21	--
265	3	-0.66	--	--	--	--	0.93	--	--
268	2	1.39	1.21	--	--	--	--	--	--
270	3	0.88	--	--	--	--	1.14	--	--
273	4	0.22	--	--	--	--	1.05	--	--
274	4	-0.44	--	--	--	--	--	--	0.96
277	1	1.68	--	--	--	--	1.25	--	--
279	0	-2.63	--	--	--	--	--	--	0.66
287	4	0.12	--	--	1.04	--	--	--	--
297	0	2.55	--	--	--	--	1.37	--	--
305	0	3.28	--	--	--	--	1.47	--	--

Lab	Rating	Z-value	Methods						
			0	1	2	3	4	6	12
306	0	3.38	--	1.48	--	--	--	--	--
309	0	21.73	--	--	--	--	4.00	--	--
315	3	0.80	--	--	--	--	1.13	--	--
328	0	3.94	--	--	--	--	1.56	--	--
331	0	2.04	--	--	--	--	1.30	--	--

Table 11. Statistical summary of reported data for standard reference samples T-163 (trace constituents) -- Continued

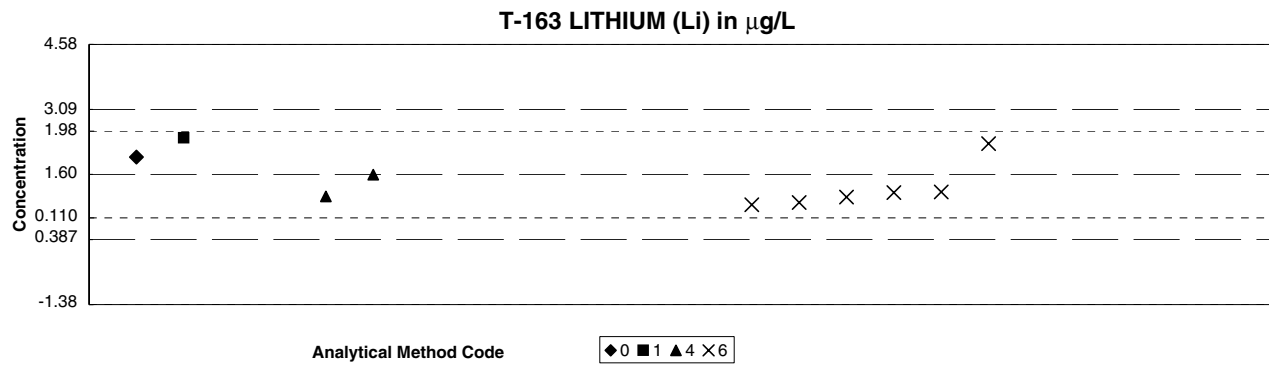

Summary	Methods				Method Codes	Statistics	
	0	1	4	6			
N =	1	1	5	6	0. Other	MPV =	1.60 µg/L
Minimum =	2.00	2.44	1.10	0.910	1. Atomic absorption: direct, air	F-pseudosigma =	0.993
Maximum =			9.00	2.31	4. Inductively coupled plasma	N =	13
Median =			5.05	1.13	6. Inductively coupled plasma/mass spectrometry	Uh =	2.44
F-pseudosigma =			3.26	0.178		Lh =	1.10

Lab	Rating	Z-value	Methods			
			0	1	4	6
1	4	-0.41	--	--	--	1.19
25	0	7.45	--	--	9.00	--
32	3	-0.52	--	--	--	1.08
42	NR	--	--	--	<5	--
50	3	-0.64	--	--	--	0.96
57	4	0.00	--	--	1.60	--
69	NR	--	--	<50	--	--
105	NR	--	--	--	<26.0	--
109	3	0.85	--	2.44	--	--
127	NR	--	--	--	<10	--
134	4	-0.50	--	--	1.10	--
212	NR	--	--	--	--	<10
235	3	-0.69	--	--	--	0.91
247	3	0.71	--	--	--	2.31
256	4	0.40	2.00	--	--	--
257	NR	--	--	<25	--	--
265	4	-0.40	--	--	--	1.20
270	0	3.47	--	--	5.05	--
273	0	4.43	--	--	6.00	--
328	NR	--	--	--	--	<10
331	NR	--	--	--	<2	--

Table 11. Statistical summary of reported data for standard reference samples T-163 (trace constituents) -- Continued

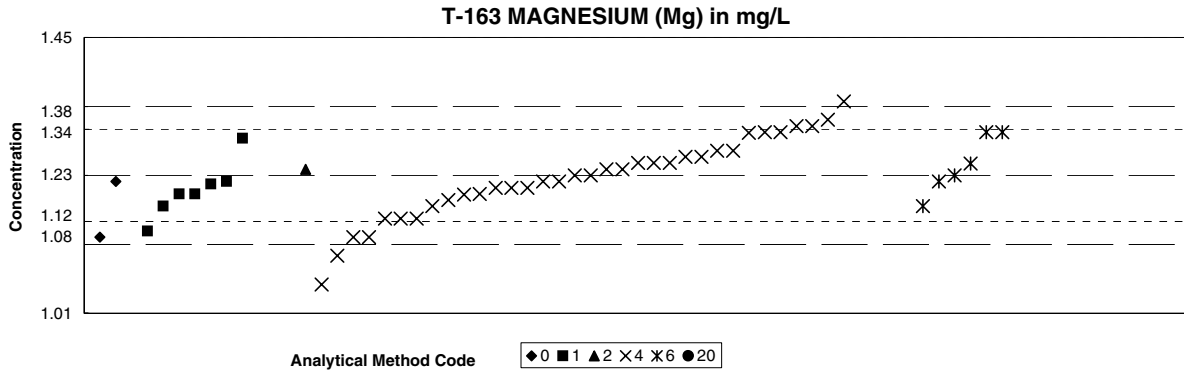

Summary	Methods						Statistics
	0	1	2	4	6	20	
N =	2	10	1	38	6	2	MPV = 1.23 mg/L
Minimum =	1.13	0.94	1.24	1.05	1.18	2.13	F-pseudosigma = 0.074
Maximum =	1.22	35.3	14.0	1.30	4.15		N = 59
Median =		1.21	1.24	1.24			Uh = 1.30
F-pseudosigma =		0.082	0.075	0.059			Lh = 1.20
	Method Codes						
	0. Other						
	1. Atomic absorption: direct, air						
	2. Atomic absorption: direct, nitrous oxide						
	4. Inductively coupled plasma						
	6. Inductively coupled plasma/mass spectrometry						
	20. Titration: colorimetric						

Lab	Rating	Z-value	Methods					
			0	1	2	4	6	20
1	3	0.54	--	--	--	1.27	--	--
12	2	1.21	--	--	--	1.32	--	--
13	3	0.94	--	--	--	1.30	--	--
23	3	-0.67	--	1.18	--	--	--	--
24	3	-0.67	--	--	--	1.18	--	--
25	0	-2.38	--	--	--	1.05	--	--
32	3	0.94	--	--	--	1.30	--	--
42	4	0.00	--	--	--	1.23	--	--
45	0	-3.89	--	0.94	--	--	--	--
48	4	-0.13	--	--	--	1.22	--	--
50	4	0.00	--	--	--	1.23	--	--
57	2	1.07	--	--	--	1.31	--	--
59	3	0.94	--	--	--	1.30	--	--
64	4	-0.27	--	--	--	1.21	--	--
69	NR	--	--	<2.0	--	--	--	--
70	4	0.40	--	--	--	1.26	--	--
76	4	0.26	--	--	--	1.25	--	--
81	4	0.00	--	--	--	1.23	--	--
86	3	0.54	--	--	--	1.27	--	--
87	2	-1.21	--	1.14	--	--	--	--
89	3	0.81	--	1.29	--	--	--	--
97	4	-0.40	--	1.20	--	--	--	--
105	4	-0.13	--	--	--	1.22	--	--
107	4	-0.13	--	1.22	--	--	--	--
109	0	3.62	--	1.50	--	--	--	--
110	3	0.93	--	--	--	1.30	--	--
113	4	-0.13	1.22	--	--	--	--	--
121	3	-0.94	--	--	--	1.16	--	--
127	1	1.61	--	--	--	1.35	--	--
134	4	-0.42	--	--	--	1.20	--	--
138	3	-0.54	--	--	--	1.19	--	--
140	4	-0.40	--	1.20	--	--	--	--
142	0	4.30	--	--	--	1.55	--	--
154	1	-1.74	--	--	--	1.10	--	--
180	0	73.83	--	--	--	6.73	--	--
193	4	0.13	--	--	--	1.24	--	--
198	2	-1.34	--	--	--	1.13	--	--
203	2	-1.34	--	--	--	1.13	--	--
204	4	0.27	--	--	--	1.25	--	--
212	3	-0.67	--	--	--	1.18	--	--
215	0	171.41	--	--	--	14.00	--	--
220	4	-0.27	--	--	--	1.21	--	--
234	4	0.27	--	--	--	1.25	--	--
235	3	-0.94	--	--	--	1.16	--	--
247	3	-0.94	--	--	--	1.16	--	--
254	4	0.13	--	--	--	1.24	--	--
255	4	-0.13	--	--	--	1.22	--	--
261	0	457.32	--	35.30	--	--	--	--
265	4	0.27	--	--	--	1.25	--	--
268	4	-0.19	--	1.22	--	--	--	--

Lab	Rating	Z-value	Methods					
			0	1	2	4	6	20
273	4	0.40	--	--	--	1.26	--	--
274	0	12.08	--	--	--	--	--	2.13
279	0	39.19	--	--	--	--	--	4.15
287	4	0.13	--	--	1.24	--	--	--
297	2	1.07	--	--	--	1.31	--	--
305	4	-0.27	--	--	--	1.21	--	--
309	2	-1.34	1.13	--	--	--	--	--
315	4	-0.40	--	--	--	1.20	--	--
328	3	0.94	--	--	--	1.30	--	--
331	0	3.76	--	--	--	1.51	--	--

Table 11. Statistical summary of reported data for standard reference samples T-163 (trace constituents) -- Continued

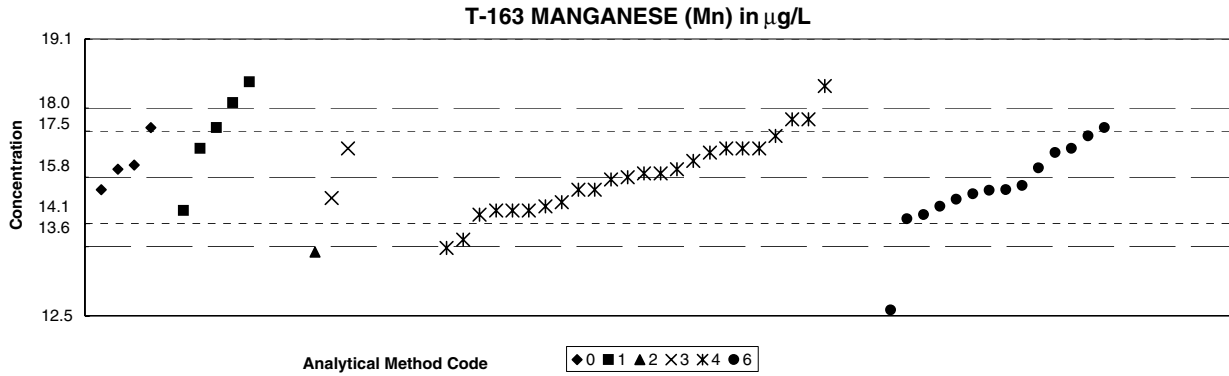

Summary	Methods						Statistics
	0	1	2	3	4	6	
N =	4	6	1	4	28	14	MPV = 15.8 µg/L
Minimum =	15.5	4.50	14.0	15.3	0.014	12.6	F-pseudosigma = 1.11
Maximum =	17.0	18.1		72.8	21.0	17.0	N = 57
Median =		16.8			15.8	15.5	Uh = 16.5
F-pseudosigma =		1.93			1.11	0.964	Lh = 15.0

Method Codes:
 0. Other
 1. Atomic absorption: direct, air
 2. Atomic absorption: direct, nitrous oxide
 3. Atomic absorption: graphite furnace
 4. Inductively coupled plasma
 6. Inductively coupled plasma/mass spectrometry

Lab	Rating	Z-value	Methods					
			0	1	2	3	4	6
1	4	-0.28	--	--	--	--	--	15.5
10	1	1.62	--	17.6	--	--	--	--
13	2	1.26	--	--	--	--	17.2	--
18	4	0.21	--	--	--	--	--	16.0
23	3	-0.81	--	--	--	--	14.9	--
24	4	0.18	--	--	--	--	16.0	--
25	0	-3.69	--	--	--	--	11.7	--
32	3	0.63	--	--	--	--	--	16.5
42	4	-0.27	--	--	--	--	--	15.5
45	2	1.08	--	17.0	--	--	--	--
48	3	0.90	--	--	--	--	--	16.8
50	3	-0.90	--	--	--	--	--	14.8
57	3	-0.63	--	--	--	--	15.1	--
59	3	-0.63	--	--	--	--	--	15.1
69	NR	--	--	<20	--	--	--	--
70	2	1.08	--	--	--	--	--	17.0
81	3	-0.72	--	--	--	--	15.0	--
86	4	0.00	--	--	--	--	15.8	--
87	2	1.26	--	--	--	--	17.2	--
89	0	3.06	--	--	--	--	19.2	--
96	NR	--	--	<20.0	--	--	--	--
105	3	0.54	--	--	--	--	16.4	--
107	NR	--	--	<40	--	--	--	--
109	3	0.63	--	16.5	--	--	--	--
113	4	-0.27	15.5	--	--	--	--	--
118	3	0.63	--	--	--	16.5	--	--
121	3	-0.72	--	--	--	--	15.0	--
127	2	-1.35	--	--	--	--	14.3	--
134	4	-0.04	--	--	--	--	15.8	--
138	3	-0.54	--	--	--	--	15.2	--
140	3	-0.72	--	15.0	--	--	--	--
142	NR	--	--	--	--	--	<10	--
147	4	0.27	16.1	--	--	--	--	--
154	4	-0.27	--	--	--	--	15.5	--
180	NR	--	--	--	--	--	<0.94	--
190	4	-0.45	--	--	--	15.3	--	--
198	3	-0.81	--	--	--	--	--	14.9
203	0	-6.12	--	--	--	--	9.0	--
204	4	-0.18	--	--	--	--	--	15.6
212	3	0.54	--	--	--	--	--	16.4
215	1	1.98	--	--	--	--	18.0	--
234	4	0.09	--	--	--	--	15.9	--
235	4	-0.48	--	--	--	--	--	15.3
247	0	-2.88	--	--	--	--	--	12.6
254	4	0.09	--	--	--	--	15.9	--
255	3	0.63	--	--	--	--	16.5	--
256	2	1.08	17.0	--	--	--	--	--
265	3	0.63	--	--	--	--	16.5	--
270	3	0.90	--	--	--	--	--	16.8
273	3	0.63	--	--	--	--	16.5	--

Lab	Rating	Z-value	Methods					
			0	1	2	3	4	6
274	0	51.28	--	--	--	72.8	--	--
277	1	-1.53	--	--	--	--	14.1	--
287	1	-1.62	--	--	14.0	--	--	--
297	4	0.36	--	--	--	--	16.2	--
304	4	0.18	16.0	--	--	--	--	--
305	4	-0.27	--	--	--	--	15.5	--
307	0	-10.16	--	4.5	--	--	--	--
315	0	-14.20	--	--	--	--	0.0	--
324	0	2.07	--	18.1	--	--	--	--
328	0	4.68	--	--	--	--	21.0	--
331	3	-0.72	--	--	--	--	15.0	--
334	4	-0.36	--	--	--	--	--	15.4

Table 11. Statistical summary of reported data for standard reference samples T-163 (trace constituents) -- Continued

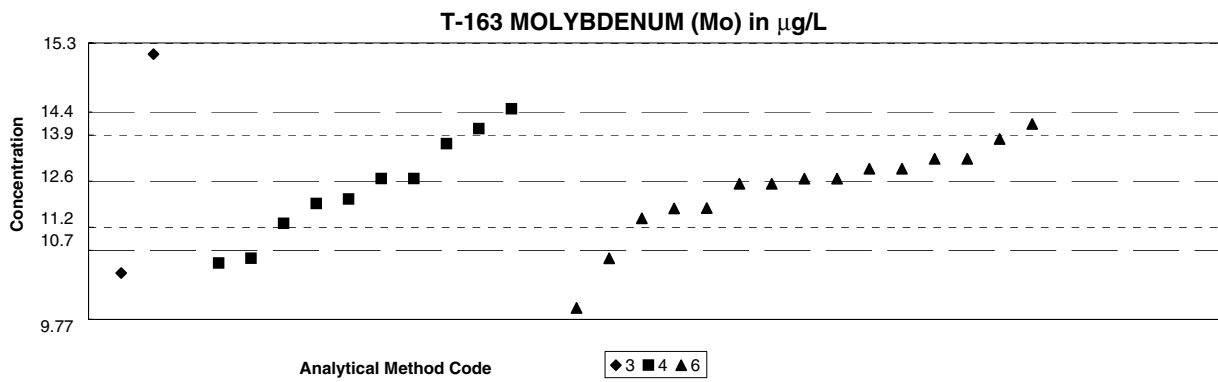

Summary	Methods			Method Codes	Statistics
	3	4	6		
N =	2	11	15		MPV = 12.6 µg/L
Minimum =	10.7	9.50	10.0	3. Atomic absorption: graphite furnace	F-pseudosigma = 0.926
Maximum =	15.1	14.0	13.7	4. Inductively coupled plasma	N = 28
Median =		12.2	12.6	6. Inductively coupled plasma/mass spectrometry	Uh = 13.0
F-pseudosigma =		1.19	0.662		Lh = 11.8

Lab	Rating	Z-value	Methods		
			3	4	6
1	4	0.48	--	--	13.0
18	3	-0.58	--	--	12.0
23	3	0.81	--	13.3	--
32	4	0.05	--	--	12.6
42	3	-0.59	--	--	12.0
48	4	0.49	--	--	13.0
50	4	-0.05	--	--	12.5
57	1	-1.78	--	10.9	--
70	3	0.92	--	--	13.4
81	1	-1.67	--	11.0	--
87	0	-3.30	--	9.5	--
97	1	-2.00	10.7	--	--
105	2	1.24	--	--	13.7
121	1	-1.67	--	--	11.0
127	0	2.76	15.1	--	--
134	4	-0.39	--	12.2	--
138	4	0.05	--	12.6	--
142	4	0.05	--	--	12.6
154	4	-0.49	--	12.1	--
180	NR	--	--	<6.05	--
198	4	0.27	--	--	12.8
212	0	-2.76	--	--	10.0
234	3	-0.92	--	11.7	--
247	4	-0.05	--	--	12.5
265	4	0.27	--	--	12.8
273	2	1.13	--	13.6	--
305	4	0.05	--	12.6	--
328	3	-0.81	--	--	11.8
331	1	1.57	--	14.0	--

Table 11. Statistical summary of reported data for standard reference samples T-163 (trace constituents) -- Continued

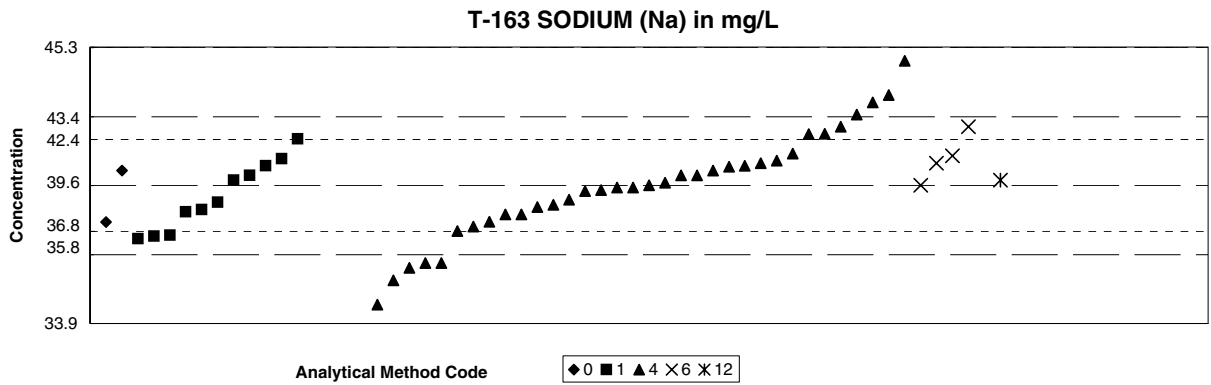

Summary		Methods					Statistics	
		0	1	4	6	12		
N =		2	12	37	4	4	MPV = 39.6 mg/L	
Minimum =		38.1	37.4	3.81	39.6	28.5	F-pseudsigma = 1.89	
Maximum =		40.2	50.9	44.7	42.0	48.8	Rating criterion= 1.98	
Median =			39.4	39.5			N = 59	
F-pseudsigma =		1.86	1.93				Uh = 40.6	
							Lh = 38.1	

Methods	
Method Codes	
0. Other	
1. Atomic absorption: direct, air	
4. Inductively coupled plasma	
6. Inductively coupled plasma/mass spectrometry	
12. Flame emission	

Lab	Rating	Z-value	Methods				
			0	1	4	6	12
1	2	1.07	--	--	41.7	--	--
12	4	-0.45	--	--	38.7	--	--
13	4	0.51	--	--	40.6	--	--
23	2	-1.11	--	37.4	--	--	--
24	4	-0.05	--	--	39.5	--	--
25	3	-0.86	--	--	37.9	--	--
32	2	1.21	--	--	--	42.0	--
42	4	-0.10	--	--	39.4	--	--
45	2	-1.04	--	37.6	--	--	--
48	4	0.45	--	--	--	40.5	--
50	3	0.61	--	--	--	40.8	--
57	0	-18.08	--	--	3.8	--	--
59	0	3.69	--	--	--	--	46.9
69	4	0.10	--	--	--	--	39.8
70	2	1.46	--	--	42.5	--	--
81	3	0.66	--	--	40.9	--	--
86	4	0.45	--	--	40.5	--	--
87	4	-0.51	--	38.6	--	--	--
89	3	-0.56	--	38.5	--	--	--
105	4	0.00	--	--	39.6	--	--
107	4	0.40	--	40.4	--	--	--
109	4	0.10	--	39.8	--	--	--
113	4	0.30	40.2	--	--	--	--
118	4	0.20	--	40.0	--	--	--
121	4	0.30	--	--	40.2	--	--
127	4	0.20	--	--	40.0	--	--
134	3	0.55	--	40.7	--	--	--
138	4	-0.30	--	--	39.0	--	--
140	2	-1.06	--	37.5	--	--	--
142	1	1.87	--	--	43.3	--	--
154	1	-1.62	--	--	36.4	--	--
180	0	2.58	--	--	44.7	--	--
193	4	-0.40	--	--	38.8	--	--
198	1	-1.62	--	--	36.4	--	--
203	4	0.38	--	--	40.4	--	--
204	2	1.06	--	--	41.7	--	--
212	4	0.00	--	--	--	39.6	--
215	2	1.21	--	--	42.0	--	--
220	3	-0.95	--	--	37.7	--	--
234	4	-0.05	--	--	39.5	--	--
235	3	-0.61	--	--	38.4	--	--
247	4	-0.12	--	--	39.4	--	--
254	4	0.40	--	--	40.4	--	--
265	4	0.05	--	--	39.7	--	--
268	4	-0.35	--	38.9	--	--	--
270	3	-0.76	--	--	38.1	--	--
273	4	0.20	--	--	40.0	--	--
274	0	4.62	--	--	--	--	48.8
277	0	-7.47	--	--	24.8	--	--
279	0	-5.63	--	--	--	--	28.5

Lab	Rating	Z-value	0	1	4	6	12
287	3	-0.77	38.1	--	--	--	--
297	1	-1.72	--	--	36.2	--	--
305	0	-2.88	--	--	33.9	--	--
306	0	5.71	--	50.9	--	--	--
307	3	0.96	--	41.5	--	--	--
309	1	-1.97	--	--	35.7	--	--
315	3	-0.61	--	--	38.4	--	--
328	1	1.72	--	--	43.0	--	--
331	0	-2.47	--	--	34.7	--	--

Table 11. Statistical summary of reported data for standard reference samples T-163 (trace constituents) -- Continued

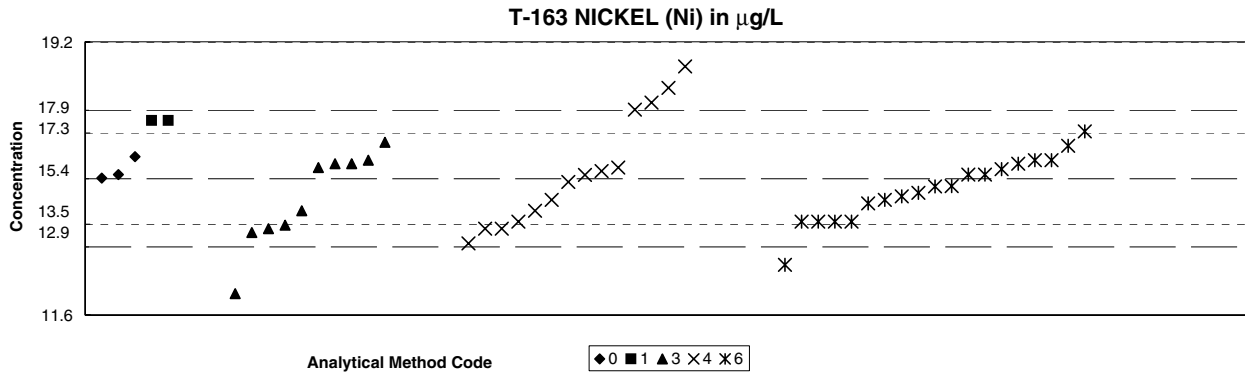

Summary	Methods					Statistics
	0	1	3	4	6	
N =	3	3	12	18	19	MPV = 15.4 µg/L
Minimum =	15.4	17.0	11.5	6.00	13.0	F-pseudosigma = 1.26
Maximum =	16.0	22.0	29.0	30.3	16.7	N = 55
Median =			15.1	15.1	15.2	Uh = 15.9
F-pseudosigma =			1.41	2.45	0.945	Lh = 14.2

Lab	Rating	Z-value	Methods				
			0	1	3	4	6
1	4	0.24	--	--	15.7	--	--
13	NR	--	--	--	--	<20	--
18	4	0.20	--	--	--	--	15.7
23	3	-0.71	--	--	--	14.5	--
25	0	-4.29	--	--	--	10.0	--
32	3	-0.56	--	--	--	--	14.7
42	4	0.08	--	--	--	--	15.5
45	0	5.24	--	22.0	--	--	--
48	4	-0.32	--	--	--	--	15.0
50	4	-0.40	--	--	--	--	14.9
57	4	0.16	--	--	--	15.6	--
59	3	-0.95	--	--	--	--	14.2
69	NR	--	--	<50	--	--	--
70	4	0.40	--	--	--	--	15.9
76	4	-0.17	--	--	--	--	15.2
81	0	-7.46	--	--	--	6.0	--
86	2	1.51	--	--	--	--	17.3
87	0	-3.97	--	--	--	10.4	--
89	3	-0.71	--	--	--	14.5	--
96	2	-1.03	--	--	--	14.1	--
97	4	0.32	--	--	--	15.8	--
105	4	0.40	--	--	--	--	15.9
107	3	-0.95	--	--	--	--	14.2
113	4	0.08	15.5	--	--	--	--
118	4	0.40	--	--	--	15.9	--
121	2	-1.11	--	--	--	14.0	--
127	2	-1.19	--	--	--	13.9	--
134	4	0.07	--	--	--	15.5	--
138	1	1.67	--	--	--	17.5	--
140	2	1.27	--	17.0	--	--	--
142	4	-0.48	--	--	--	14.8	--
144	0	-2.54	--	--	--	12.2	--
154	4	-0.08	--	--	--	15.3	--
180	NR	--	--	--	--	<15.6	--
190	4	0.32	--	--	--	15.8	--
193	3	0.79	--	--	--	16.4	--
198	3	-0.95	--	--	--	--	14.2
203	NR	--	--	--	--	<30	--
204	3	-0.95	--	--	--	--	14.2
212	3	0.71	--	--	--	--	16.3
215	0	10.79	--	--	--	29.0	--
234	4	0.24	--	--	--	15.7	--
235	4	-0.18	--	--	--	--	15.2
247	4	-0.48	--	--	--	--	14.8
254	NR	--	--	--	--	<15	--
255	2	1.03	--	--	--	--	16.7
256	4	0.48	16.0	--	--	--	--
257	2	1.27	--	17.0	--	--	--
265	4	0.08	--	--	--	--	15.5
270	0	11.82	--	--	--	30.3	--

Lab	Rating	Z-value	Methods				
			0	1	3	4	6
273	0	2.46	--	--	--	18.5	--
277	2	-1.43	--	--	--	13.6	--
297	1	1.98	--	--	--	17.9	--
304	4	0.00	15.4	--	--	--	--
305	3	-0.95	--	--	--	14.2	--
306	0	-3.13	--	--	--	11.5	--
307	2	-1.11	--	--	--	14.0	--
328	1	-1.90	--	--	--	--	13.0
331	2	-1.11	--	--	--	14.0	--
334	4	0.32	--	--	--	--	15.8

Table 11. Statistical summary of reported data for standard reference samples T-163 (trace constituents) -- Continued

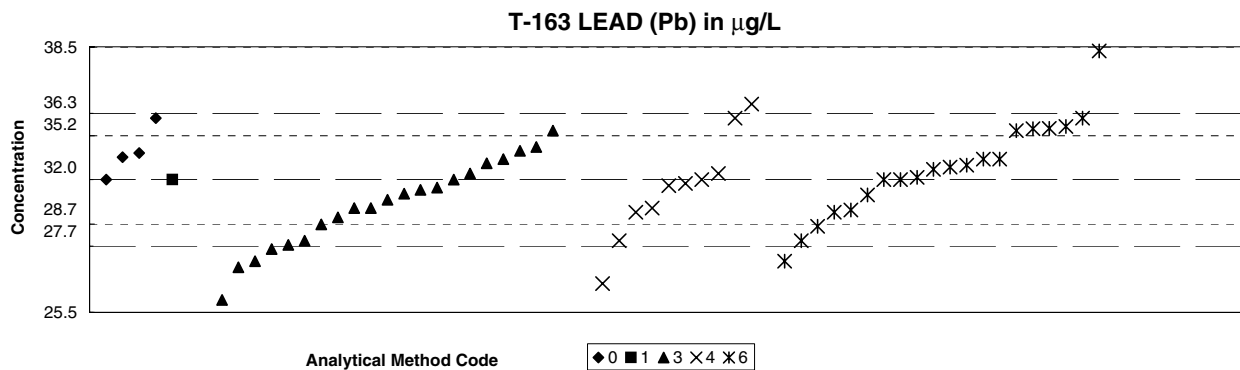

Summary	Methods					Statistics	
	0	1	3	4	6	Method Codes	
N =	4	2	23	11	20	0. Other	MPV = 32.0 µg/L
Minimum =	32.0	32.0	15.0	19.6	28.0	1. Atomic absorption: direct, air	F-pseudostigma = 2.17
Maximum =	35.0	47.5	48.7	35.7	38.3	3. Atomic absorption: graphite furnace	N = 60
Median =			31.0	31.7	32.6	4. Inductively coupled plasma	Uh = 33.2
F-pseudostigma =			2.71	1.82	2.65	6. Inductively coupled plasma/mass spectrometry	Lh = 30.3

Lab	Rating	Z-value	Methods				
			0	1	3	4	6
1	4	0.32	--	--	--	--	32.7
10	2	-1.38	--	--	29.0	--	--
12	4	0.14	--	--	32.3	--	--
13	3	-0.65	--	--	30.6	--	--
18	2	1.15	--	--	--	--	34.5
23	3	-0.65	--	--	30.6	--	--
25	0	-2.35	--	--	26.9	--	--
32	4	0.05	--	--	--	--	32.1
42	4	0.28	--	--	--	--	32.6
45	3	0.74	--	--	33.6	--	--
48	4	0.46	--	--	--	--	33.0
50	2	-1.06	--	--	--	--	29.7
57	3	-0.74	--	--	30.4	--	--
59	2	1.15	--	--	--	--	34.5
69	4	0.37	--	--	32.8	--	--
81	1	-1.84	--	--	28.0	--	--
86	4	0.00	--	--	32.0	--	--
87	2	1.38	--	--	35.0	--	--
89	0	-2.72	--	--	26.1	--	--
96	3	0.65	--	--	33.4	--	--
97	4	-0.46	--	--	31.0	--	--
105	2	1.11	--	--	--	--	34.4
107	2	1.38	--	--	--	--	35.0
113	4	0.46	--	--	33.0	--	--
118	3	-0.65	--	--	30.6	--	--
121	4	0.00	--	--	--	--	32.0
127	4	-0.18	--	--	31.6	--	--
134	4	0.00	--	--	32.0	--	--
138	4	0.14	--	--	32.3	--	--
140	4	0.00	--	32.0	--	--	--
142	3	-0.74	--	--	--	--	30.4
144	2	1.11	--	--	34.4	--	--
147	4	0.51	33.1	--	--	--	--
154	2	-1.48	--	--	28.8	--	--
180	NR	--	--	--	--	--	<28.5
190	4	-0.32	--	--	31.3	--	--
193	4	-0.23	--	--	31.5	--	--
198	3	-0.69	--	--	--	--	30.5
203	2	-1.01	--	--	29.8	--	--
204	0	2.91	--	--	--	--	38.3
212	2	-1.38	--	--	--	--	29.0
215	0	-7.84	--	--	15.0	--	--
220	1	-1.98	--	--	27.7	--	--
234	4	-0.14	--	--	31.7	--	--
235	4	-0.35	--	--	--	--	31.2
247	4	0.46	--	--	--	--	33.0
255	2	1.20	--	--	--	--	34.6
256	2	1.38	35.0	--	--	--	--
257	0	7.15	--	47.5	--	--	--
265	4	0.00	--	--	--	--	32.0

Lab	Rating	Z-value	Methods				
			0	1	3	4	6
273	0	-5.72	--	--	--	19.6	--
274	0	7.68	--	--	48.7	--	--
277	3	0.60	33.3	--	--	--	--
287	3	-0.85	--	--	30.2	--	--
297	4	-0.09	--	--	--	31.8	--
304	4	0.00	32.0	--	--	--	--
305	1	1.71	--	--	--	35.7	--
307	1	-1.57	--	--	28.6	--	--
328	1	-1.84	--	--	--	--	28.0
331	2	-1.38	--	--	--	29.0	--
334	4	0.23	--	--	--	--	32.5

Table 11. Statistical summary of reported data for standard reference samples T-163 (trace constituents) -- Continued

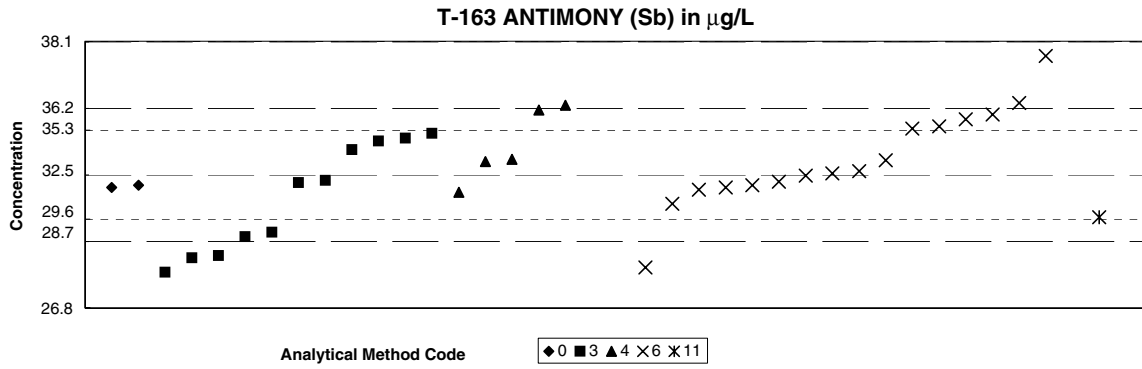

Summary	Methods					Statistics
	0	3	4	6	11	
N =	2	11	5	17	1	MPV = 32.5 µg/L
Minimum =	31.9	28.3	31.7	28.5	30.6	F-pseudostigma = 1.89
Maximum =	32.0	34.2	35.4	38.5		N = 36
Median =		32.1	33.1	32.6		Uh = 34.3
F-pseudostigma =		3.18	1.63	2.08		Lh = 31.8
	Method Codes					
	0. Other					
	3. Atomic absorption: graphite furnace					
	4. Inductively coupled plasma					
	6. Inductively coupled plasma/mass spectrometry					
	11. Atomic absorption: hydride					

Lab	Rating	Z-value	Methods				
			0	3	4	6	11
1	4	-0.16	--	--	--	32.1	--
13	4	-0.19	--	32.1	--	--	--
18	0	2.67	--	--	--	37.5	--
23	1	1.56	--	--	35.4	--	--
25	NR	--	--	--	<60	--	--
32	2	1.08	--	--	--	34.5	--
42	4	-0.29	--	--	--	31.9	--
45	3	0.82	--	34.0	--	--	--
48	2	1.35	--	--	--	35.0	--
50	4	-0.34	--	--	--	31.8	--
57	4	-0.40	--	--	31.7	--	--
59	1	1.61	--	--	--	35.5	--
69	0	-2.20	--	28.3	--	--	--
70	2	1.24	--	--	--	34.8	--
76	4	0.32	--	--	--	33.1	--
81	2	-1.30	--	30.0	--	--	--
89	1	-1.88	--	28.9	--	--	--
96	4	-0.13	--	32.2	--	--	--
105	4	0.08	--	--	--	32.6	--
113	4	-0.29	31.9	--	--	--	--
127	2	-1.40	--	29.8	--	--	--
134	3	0.76	--	33.9	--	--	--
138	4	0.34	--	--	33.1	--	--
142	0	3.20	--	--	--	38.5	--
154	3	0.93	--	34.2	--	--	--
180	NR	--	--	--	<26.6	--	--
193	1	-1.83	--	29.0	--	--	--
198	3	-0.66	--	--	--	31.2	--
204	4	-0.03	--	--	--	32.4	--
212	0	-2.09	--	--	--	28.5	--
234	3	0.56	--	33.5	--	--	--
247	4	-0.24	--	--	--	32.0	--
257	3	-0.96	--	--	--	--	30.6
265	4	0.03	--	--	--	32.5	--
297	2	1.45	--	--	35.2	--	--
304	4	-0.24	32.0	--	--	--	--
328	2	1.03	--	--	--	34.4	--
331	4	0.29	--	--	33.0	--	--

Table 11. Statistical summary of reported data for standard reference samples T-163 (trace constituents) -- Continued

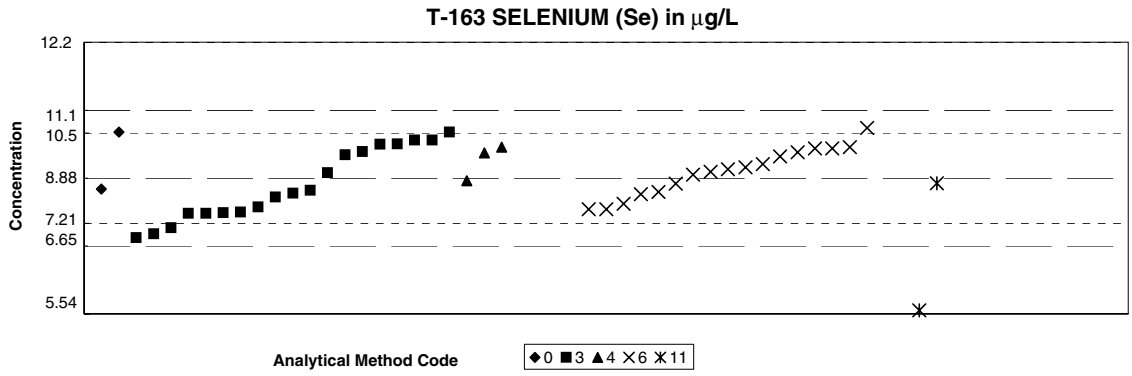

Summary	Methods					Statistics
	0	3	4	6	11	
N =	2	19	4	17	4	MPV = 8.88 µg/L
Minimum =	8.60	7.40	8.80	8.10	0.320	F-pseudostigma = 1.11
Maximum =	10.0	10.0	13.0	10.1	8.74	N = 46
Median =		8.50		9.09		Uh = 9.60
F-pseudostigma =		1.19		0.719		Lh = 8.10

Method Codes
0. Other
3. Atomic absorption: graphite furnace
4. Inductively coupled plasma
6. Inductively coupled plasma/mass spectrometry
11. Atomic absorption: hydride

Lab	Rating	Z-value	Methods				
			0	3	4	6	11
1	4	0.19	--	--	--	9.09	--
10	4	0.11	--	9.00	--	--	--
12	2	-1.33	--	7.40	--	--	--
13	3	0.83	--	9.80	--	--	--
18	4	0.30	--	--	--	9.21	--
23	4	-0.07	--	--	8.80	--	--
25	NR	--	--	--	<11	--	--
42	4	-0.31	--	--	--	8.53	--
48	3	-0.70	--	--	--	8.10	--
50	4	-0.13	--	--	--	8.73	--
57	0	3.71	--	--	13.00	--	--
59	3	0.65	--	--	--	9.60	--
69	3	-0.79	--	8.00	--	--	--
70	4	0.07	--	--	--	8.95	--
81	3	-0.79	--	8.00	--	--	--
86	4	-0.12	--	--	--	--	8.74
87	0	-6.09	--	--	--	--	2.10
89	0	-2.93	--	--	--	--	5.62
96	3	-0.76	--	8.03	--	--	--
105	4	0.47	--	--	--	9.40	--
107	2	1.10	--	--	--	10.10	--
113	4	-0.27	--	8.57	--	--	--
118	2	-1.10	--	7.65	--	--	--
127	3	0.75	--	9.71	--	--	--
134	2	1.01	--	10.00	--	--	--
138	3	0.68	--	--	9.63	--	--
142	3	0.68	--	--	--	9.63	--
144	2	-1.24	--	7.50	--	--	--
154	3	0.83	--	9.80	--	--	--
180	NR	--	--	--	<65.2	--	--
190	3	-0.64	--	8.16	--	--	--
193	3	0.74	--	9.70	--	--	--
198	4	0.23	--	--	--	9.13	--
203	4	-0.43	--	8.40	--	--	--
204	3	-0.57	--	--	--	8.24	--
212	3	-0.70	--	--	--	8.10	--
215	4	-0.34	--	8.50	--	--	--
220	3	0.58	--	9.52	--	--	--
234	4	0.51	--	9.44	--	--	--
247	4	-0.36	--	--	--	8.47	--
255	4	0.13	--	--	--	9.02	--
256	2	1.01	10.00	--	--	--	--
257	0	-7.69	--	--	--	--	0.32
265	3	0.56	--	--	--	9.50	--
297	3	0.55	--	--	9.49	--	--
304	4	-0.25	8.60	--	--	--	--
307	3	-0.77	--	8.02	--	--	--
328	3	0.65	--	--	--	9.60	--
331	NR	--	--	--	<40	--	--

Table 11. Statistical summary of reported data for standard reference samples T-163 (trace constituents) -- Continued

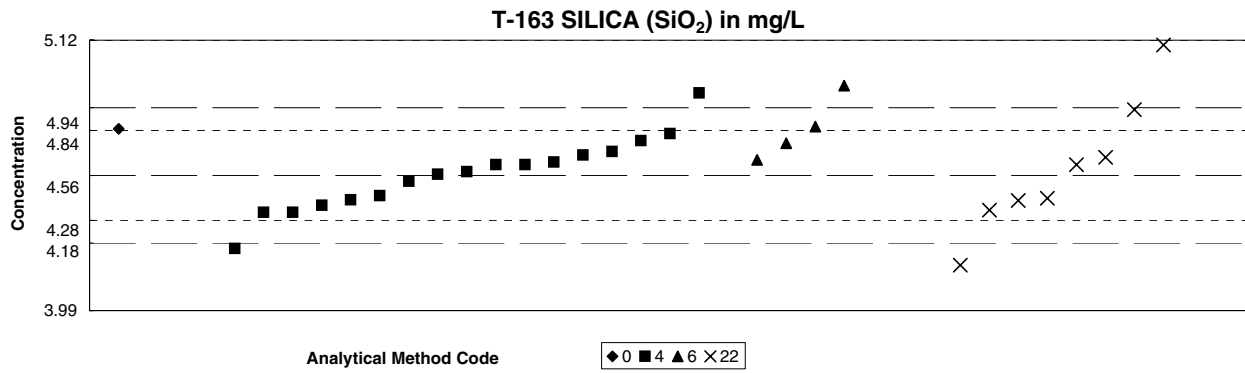

Summary	Methods				Method Codes	Statistics	
	0	4	6	22			
N =	1	20	5	11	0. Other	MPV =	4.56 mg/L
Minimum =	4.75	1.88	2.15	2.23	4. Inductively coupled plasma	F-pseudostigma =	0.188
Maximum =	4.90	4.93	5.10		6. Inductively coupled plasma/mass spectrometry	Rating criterion =	0.228
Median =		4.55	4.69	4.45	22. Colorimetric	N =	37
F-pseudostigma =		0.167	0.103	0.445		Uh =	4.65
						Lh =	4.40

Lab	Rating	Z-value	Methods			
			0	4	6	22
1	4	0.41	--	4.65	--	--
13	3	-0.70	--	4.40	--	--
24	3	0.75	--	4.73	--	--
25	0	-11.75	--	1.88	--	--
32	1	1.62	--	--	4.93	--
42	0	-2.98	--	3.88	--	--
50	4	0.26	--	--	4.62	--
57	2	-1.36	--	4.25	--	--
64	3	-0.57	--	4.43	--	--
70	2	1.18	--	--	--	4.83
87	4	-0.48	--	--	--	4.45
89	4	0.18	--	--	--	4.60
97	3	-0.66	--	--	--	4.41
105	4	-0.39	--	4.47	--	--
110	3	0.87	--	--	4.76	--
118	0	-10.22	--	--	--	2.23
121	4	0.04	--	4.57	--	--
127	4	0.35	--	4.64	--	--
134	4	-0.47	--	4.45	--	--
140	4	0.31	--	--	--	4.63
142	2	1.49	--	4.90	--	--
154	4	0.18	--	4.60	--	--
190	0	2.37	--	--	--	5.10
203	4	-0.44	--	--	--	4.46
212	0	-10.57	--	--	2.15	--
234	4	0.22	--	4.61	--	--
235	4	-0.13	--	4.53	--	--
247	1	-1.67	--	--	--	4.18
254	4	0.00	--	4.56	--	--
256	3	0.83	4.75	--	--	--
265	3	0.61	--	4.70	--	--
273	3	-0.70	--	4.40	--	--
274	0	-5.83	--	--	--	3.23
297	0	-3.11	--	--	--	3.85
309	0	-7.37	--	2.88	--	--
328	3	0.57	--	--	4.69	--
331	4	0.18	--	4.60	--	--

Table 11. Statistical summary of reported data for standard reference samples T-163 (trace constituents) -- Continued

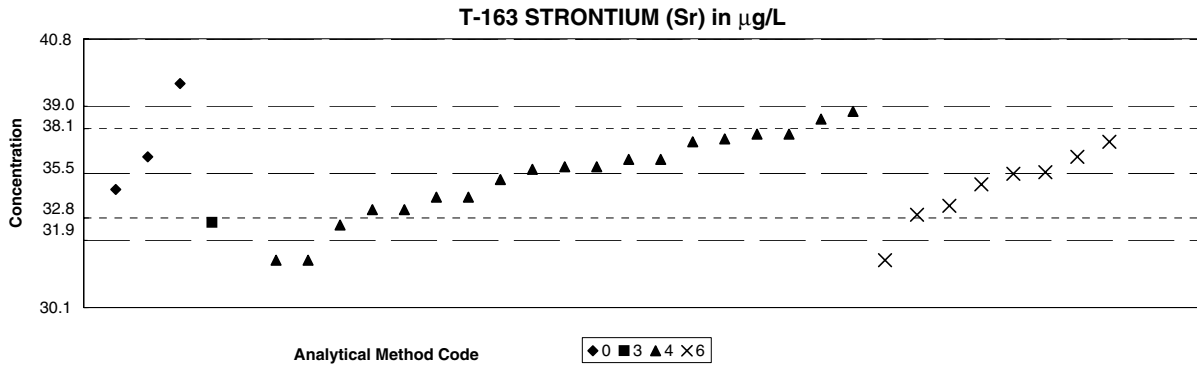

Summary	Methods				Method Codes	Statistics
	0	3	4	6		
N =	3	1	20	8		MPV = 35.5 µg/L
Minimum =	34.8	33.5	24.5	32.0	0. Other	F-pseudostigma = 1.78
Maximum =	39.0		37.9	36.7	3. Atomic absorption: graphite furnace	N = 32
Median =			35.7	35.2	4. Inductively coupled plasma	Uh = 36.4
F-pseudostigma =			2.04	1.35	6. Inductively coupled plasma/mass spectrometry	Lh = 34.0

Lab	Rating	Z-value	Methods			
			0	3	4	6
1	3	-0.73	--	--	--	34.2
24	4	0.30	--	--	36.0	--
25	0	-6.16	--	--	24.5	--
32	4	-0.26	--	--	--	35.0
42	4	0.13	--	--	35.7	--
50	4	0.36	--	--	--	36.1
57	3	-0.54	--	--	34.5	--
76	4	-0.02	--	--	--	35.4
81	4	0.30	--	--	36.0	--
86	3	0.70	--	--	36.7	--
97	2	-1.10	--	33.5	--	--
105	3	-0.82	--	--	34.0	--
113	4	-0.37	34.8	--	--	--
121	1	-1.94	--	--	32.0	--
127	3	-0.54	--	--	34.5	--
134	4	-0.15	--	--	35.2	--
138	2	-1.16	--	--	33.4	--
142	3	0.87	--	--	37.0	--
154	4	0.08	--	--	35.6	--
212	3	-0.93	--	--	--	33.8
234	4	0.13	--	--	35.7	--
235	4	0.02	--	--	--	35.5
247	3	0.70	--	--	--	36.7
254	2	1.37	--	--	37.9	--
256	1	1.99	39.0	--	--	--
265	3	-0.82	--	--	34.0	--
270	3	0.76	--	--	36.8	--
273	2	1.20	--	--	37.6	--
304	4	0.36	36.1	--	--	--
309	1	-1.94	--	--	32.0	--
328	1	-1.94	--	--	--	32.0
331	3	0.87	--	--	37.0	--

Table 11. Statistical summary of reported data for standard reference samples T-163 (trace constituents) -- Continued

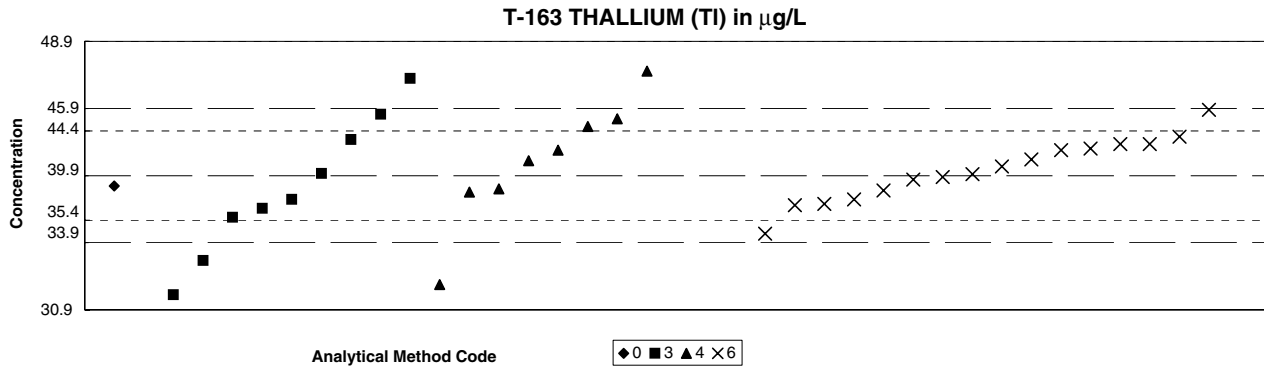

Summary	Methods				Method Codes	Statistics	
	0	3	4	6			
N =	1	10	8	17	0. Other	MPV =	39.9 µg/L
Minimum =	39.2	16.0	32.6	7.6	3. Atomic absorption: graphite furnace	F-pseudosigma =	3.00
Maximum =		46.4	46.9	44.3	4. Inductively coupled plasma	N =	36
Median =		38.0	41.3	40.0	6. Inductively coupled plasma/mass spectrometry	Uh =	42.0
F-pseudosigma =		6.00	3.37	2.52		Lh =	38.0

Lab	Rating	Z-value	Methods			
			0	3	4	6
1	4	-0.09	--	--	--	39.6
13	3	-0.93	--	37.1	--	--
18	3	0.87	--	--	--	42.5
23	4	-0.37	--	--	38.8	--
25	NR	--	--	--	<7.5	--
32	4	0.03	--	--	--	40.0
42	3	0.57	--	--	--	41.6
48	3	0.70	--	--	--	42.0
50	2	-1.30	--	--	--	36.0
57	3	0.57	--	--	41.6	--
59	2	1.47	--	--	--	44.3
69	3	0.80	--	42.3	--	--
76	4	0.36	--	--	--	41.0
81	2	1.37	--	44.0	--	--
86	0	-2.66	--	31.9	--	--
89	0	2.17	--	46.4	--	--
105	4	-0.03	--	--	--	39.8
113	3	-0.73	--	37.7	--	--
127	3	-0.53	--	38.3	--	--
134	4	0.05	--	40.0	--	--
138	2	1.27	--	--	43.7	--
142	4	0.20	--	--	--	40.5
154	1	-1.90	--	34.2	--	--
180	NR	--	--	--	<37.9	--
198	3	-0.67	--	--	--	37.9
204	0	-10.75	--	--	--	7.6
212	3	0.70	--	--	--	42.0
215	0	-7.96	--	16.0	--	--
234	0	2.33	--	--	46.9	--
235	3	-0.53	--	--	--	38.3
247	3	0.60	--	--	--	41.7
265	3	-0.63	--	--	--	38.0
270	0	-2.43	--	--	32.6	--
297	2	1.10	--	--	--	43.2
304	4	-0.23	39.2	--	--	--
305	4	0.33	--	--	40.9	--
328	4	-0.33	--	--	--	38.9
331	4	-0.30	--	--	39.0	--

Table 11. Statistical summary of reported data for standard reference samples T-163 (trace constituents) -- Continued

T-163 URANIUM (U) in µg/L

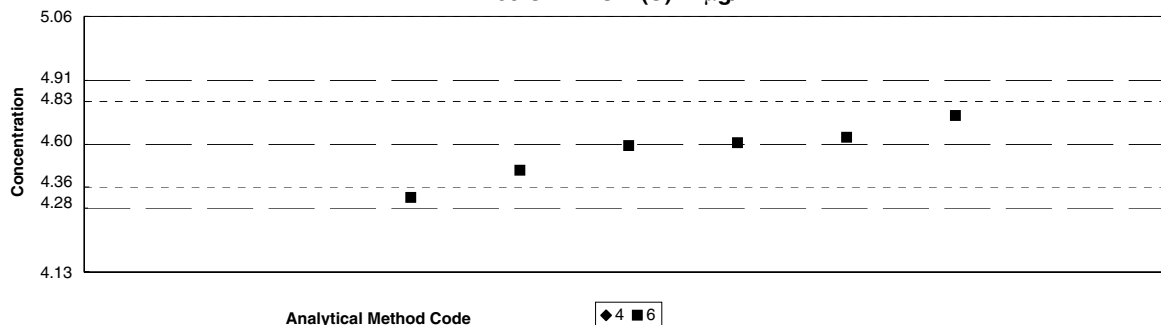

Summary	Methods		Statistics
	4	6	
N =	0	8	MPV = 4.60 µg/L
Minimum =	<100	3.60	F-pseudosigma = 0.156
Maximum =		5.07	Rating criterion = 0.230
Median =		4.60	N = 8
F-pseudosigma =		0.156	Uh = 4.66
			Lh = 4.45

Lab	Rating	Z-value	Methods	
			4	6
1	4	-0.02	--	4.59
32	4	0.02	--	4.60
76	4	0.46	--	4.70
127	NR	--	<100	--
134	0	2.07	--	5.07
142	4	0.11	--	4.62
212	3	-0.85	--	4.40
265	4	-0.41	--	4.50
328	0	-4.33	--	3.60

Table 11. Statistical summary of reported data for standard reference samples T-163 (trace constituents -- Continued

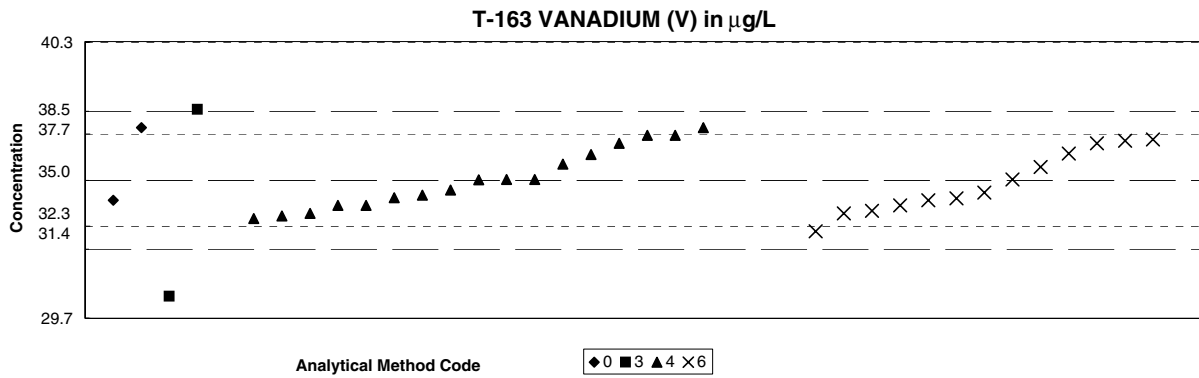

Summary	Methods				Method Codes	Statistics	
	0	3	4	6			
N =	2	2	18	13	0. Other	MPV =	35.0 µg/L
Minimum =	34.2	30.5	33.5	33.0	3. Atomic absorption: graphite furnace	F-pseudostigma =	1.78
Maximum =	37.0	37.7	42.0	36.5	4. Inductively coupled plasma	N =	35
Median =			35.0	34.5	6. Inductively coupled plasma/mass spectrometry	Uh =	36.4
F-pseudostigma =			1.78	1.48		Lh =	34.0

Lab	Rating	Z-value	Methods			
			0	3	4	6
1	4	-0.40	--	--	--	34.3
13	NR	--	--	--	<50	--
18	3	0.87	--	--	--	36.5
24	3	-0.56	--	--	34.0	--
25	3	0.79	--	--	36.4	--
32	3	0.57	--	--	--	36.0
42	4	-0.28	--	--	--	34.5
48	4	0.01	--	--	--	35.0
50	3	-0.73	--	--	--	33.7
57	3	-0.84	--	--	33.5	--
70	3	0.79	--	--	--	36.4
76	4	0.28	--	--	--	35.5
81	3	-0.56	--	--	34.0	--
86	3	0.96	--	--	36.7	--
89	1	1.52	--	37.7	--	--
96	NR	--	--	<40	--	--
97	0	-2.52	--	30.5	--	--
105	4	-0.39	--	--	34.3	--
121	2	-1.12	--	--	--	33.0
127	4	-0.33	--	--	34.4	--
134	4	0.00	--	--	35.0	--
138	3	-0.73	--	--	33.7	--
142	3	-0.56	--	--	--	34.0
154	4	-0.22	--	--	34.6	--
180	NR	--	--	--	<5.97	--
198	3	0.85	--	--	--	36.5
212	3	-0.67	--	--	--	33.8
220	3	0.55	--	--	36.0	--
234	4	0.01	--	--	35.0	--
235	3	-0.78	--	--	33.6	--
247	4	-0.44	--	--	--	34.2
256	2	1.13	37.0	--	--	--
265	2	1.13	--	--	37.0	--
297	3	0.96	--	--	36.7	--
304	4	-0.44	34.2	--	--	--
305	4	0.34	--	--	35.6	--
328	0	3.94	--	--	42.0	--
331	4	0.01	--	--	35.0	--

Table 11. Statistical summary of reported data for standard reference samples T-163 (trace constituents) -- Continued

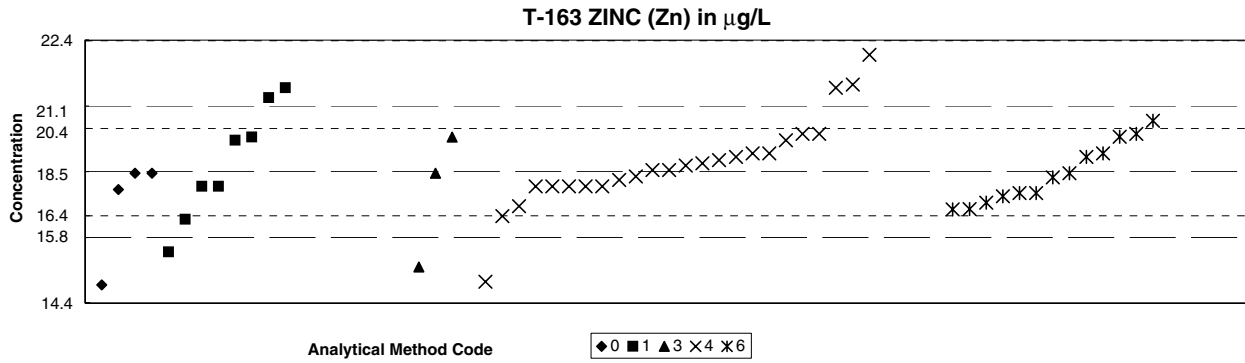

Summary	Methods						Statistics
	0	1	2	3	4	6	
N =	4	12	1	3	28	14	MPV = 18.5 µg/L
Minimum =	15.0	16.0	15.0	15.6	12.0	11.4	F-pseudostigma = 1.33
Maximum =	18.4	55.5		19.5	25.0	20.0	N = 62
Median =		20.1		18.7	18.0		Uh = 19.6
F-pseudostigma =		4.45		1.19	1.11		Lh = 17.8

Methods	
Method Codes	
0. Other	
1. Atomic absorption: direct, air	
2. Atomic absorption: direct, nitrous oxide	
3. Atomic absorption: graphite furnace	
4. Inductively coupled plasma	
6. Inductively coupled plasma/mass spectrometry	

Lab	Rating	Z-value	Methods					
			0	1	2	3	4	6
1	4	-0.13	--	--	--	--	--	18.3
10	3	0.79	--	19.5	--	--	--	--
12	3	0.79	--	--	--	19.5	--	--
13	4	0.19	--	--	--	--	18.7	--
18	3	-0.85	--	--	--	--	--	17.3
23	4	0.04	--	--	--	--	18.5	--
24	4	-0.34	--	--	--	--	18.0	--
25	0	4.91	--	--	--	--	25.0	--
32	3	-0.86	--	--	--	--	--	17.3
42	3	-0.71	--	--	--	--	--	17.5
45	4	-0.34	--	18.0	--	--	--	--
48	4	0.41	--	--	--	--	--	19.0
50	3	-0.56	--	--	--	--	--	17.7
57	0	3.93	--	--	--	--	23.7	--
59	3	0.86	--	--	--	--	--	19.6
69	NR	--	--	<50	--	--	--	--
70	2	1.16	--	--	--	--	--	20.0
81	4	0.41	--	--	--	--	19.0	--
86	4	0.34	--	--	--	--	18.9	--
87	3	0.86	--	--	--	--	19.6	--
89	4	-0.04	--	--	--	18.4	--	--
96	2	-1.09	--	17.0	--	--	--	--
105	4	-0.34	--	--	--	--	18.0	--
113	4	-0.04	18.4	--	--	--	--	--
118	1	-1.84	--	16.0	--	--	--	--
121	4	-0.34	--	--	--	--	18.0	--
127	4	0.26	--	--	--	--	18.8	--
134	4	0.13	--	--	--	--	18.6	--
138	4	-0.11	--	--	--	--	18.3	--
140	1	1.91	--	21.0	--	--	--	--
142	4	-0.04	--	--	--	--	--	18.4
144	4	-0.34	--	18.0	--	--	--	--
147	4	-0.04	18.4	--	--	--	--	--
154	0	-2.51	--	--	--	--	15.1	--
180	0	-4.83	--	--	--	--	12.0	--
190	3	0.71	--	19.4	--	--	--	--
193	0	4.91	--	25.0	--	--	--	--
198	4	-0.49	--	--	--	--	--	17.8
203	3	-0.79	--	--	--	--	17.4	--
204	4	-0.49	--	--	--	--	--	17.8
212	4	0.34	--	--	--	--	--	18.9
215	4	-0.34	--	--	--	--	18.0	--
234	3	0.86	--	--	--	--	19.6	--
235	3	0.79	--	--	--	--	--	19.5
247	0	-5.28	--	--	--	--	--	11.4
254	4	0.41	--	--	--	--	19.0	--
255	4	0.04	--	--	--	--	18.5	--
256	0	-2.59	15.0	--	--	--	--	--
257	0	23.64	--	50.0	--	--	--	--
261	0	27.77	--	55.5	--	--	--	--

Lab	Rating	Z-value	Methods					
			0	1	2	3	4	6
265	4	-0.34	--	--	--	--	18.0	--
270	0	3.36	--	--	--	--	22.9	--
273	1	1.99	--	--	--	--	21.1	--
274	0	-2.17	--	--	--	15.6	--	--
277	2	-1.01	--	--	--	--	17.1	--
287	0	-2.59	--	--	15.0	--	--	--
297	4	-0.19	--	--	--	--	18.2	--
304	4	-0.41	17.9	--	--	--	--	--
305	3	0.71	--	--	--	--	--	19.4
306	NR	--	--	<50	--	--	--	--
307	0	3.41	--	23.0	--	--	--	--
324	1	1.69	--	20.7	--	--	--	--
328	0	2.66	--	--	--	--	22.0	--
331	1	1.91	--	--	--	--	21.0	--

Table 12. Statistical summary of reported data for standard reference samples M-156 (major constituents)

M-154 ALKALINITY (as CaCO₃) in mg/L

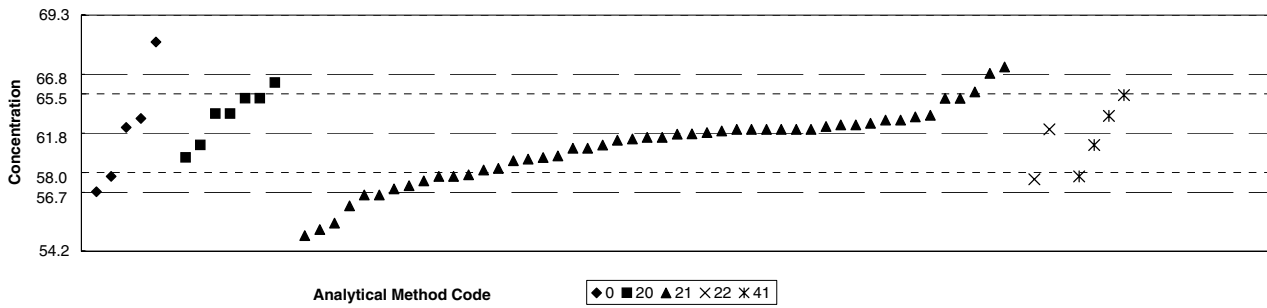

Summary	Methods					Statistics
	0	20	21	22	41	
N =	5	9	49	3	4	MPV = 61.8 mg/L
Minimum =	58.0	51.0	55.2	58.8	59.0	F-pseudostigma = 2.5
Maximum =	67.6	72.1	118.0	86.1	64.2	Rating criterion = 3.1
Median =	62.1	63.0	61.5			N = 70
F-pseudostigma =	2.7	2.2	2.1			Uh = 62.8
	Methods 0. Other 20. Titration: colorimetric 21. Titration: electrometric 22. Colorimetric 41. Electrometric [pH and specific conductance]					Lh = 59.4

Lab	Rating	Z-value	Methods				
			0	20	21	22	41
1	4	0.36	--	--	--	--	62.9
10	4	-0.25	--	--	61.0	--	--
12	4	0.14	--	--	62.2	--	--
13	2	-1.15	--	--	58.2	--	--
18	3	-0.96	--	--	--	58.8	--
23	4	-0.31	--	--	60.8	--	--
24	4	0.17	--	--	62.3	--	--
25	2	1.37	--	--	66.0	--	--
38	4	-0.01	--	--	61.7	--	--
42	4	-0.25	--	--	--	61.0	--
45	4	0.21	--	--	62.4	--	--
48	4	0.08	--	--	--	62.0	--
50	3	-0.57	--	--	60.0	--	--
55	4	0.08	--	--	62.0	--	--
57	3	0.73	--	64.0	--	--	--
59	3	-0.99	--	--	58.7	--	--
69	2	-1.28	--	--	57.8	--	--
70	4	-0.31	--	--	60.8	--	--
81	4	-0.02	--	--	61.7	--	--
87	4	-0.51	--	--	60.2	--	--
89	4	0.37	--	--	62.9	--	--
93	4	0.12	62.1	--	--	--	--
96	3	-0.73	--	--	59.5	--	--
97	4	-0.15	--	--	61.3	--	--
105	4	-0.12	--	--	61.4	--	--
107	4	-0.47	--	--	60.3	--	--
109	2	1.24	--	--	65.6	--	--
113	4	0.01	--	--	61.8	--	--
114	4	0.34	--	--	62.8	--	--
118	4	-0.25	--	61.0	--	--	--
127	4	0.27	--	--	62.6	--	--
129	3	0.73	--	64.0	--	--	--
134	4	0.30	62.7	--	--	--	--
138	4	-0.08	--	--	61.5	--	--
142	4	0.08	--	--	62.0	--	--
154	3	0.73	--	--	64.0	--	--
155	3	-0.76	--	--	59.4	--	--
190	3	-0.89	--	--	--	59.0	--
193	4	0.27	--	--	62.6	--	--
203	2	-1.28	--	--	57.8	--	--
204	3	-0.89	--	--	59.0	--	--
212	3	-0.54	--	--	60.1	--	--
213	3	-0.89	--	--	59.0	--	--
215	4	0.40	--	63.0	--	--	--
220	2	-1.51	--	--	57.1	--	--
230	3	-0.86	--	--	59.1	--	--
234	4	0.40	--	63.0	--	--	--
247	1	-1.99	--	--	55.6	--	--
257	4	-0.08	--	--	61.5	--	--
258	4	-0.51	--	60.2	--	--	--

Lab	Rating	Z-value	Methods				
			0	20	21	22	41
259	4	0.08	--	--	62.0	--	--
263	4	0.08	--	--	62.0	--	--
266	4	0.08	--	--	62.0	--	--
267	4	0.17	--	--	62.3	--	--
268	4	0.05	--	--	61.9	--	--
273	1	1.89	67.6	--	--	--	--
274	0	3.35	--	72.1	--	--	--
275	0	-3.48	--	51.0	--	--	--
276	3	0.85	--	--	64.4	--	--
277	0	18.21	--	--	118.0	--	--
287	4	0.08	--	--	62.0	--	--
297	1	-1.87	--	--	56.0	--	--
305	3	0.73	--	--	64.0	--	--
307	2	1.05	--	65.0	--	--	--
309	3	0.79	--	--	--	--	64.2
324	0	-2.12	--	--	55.2	--	--
328	3	-0.89	59.0	--	--	--	--
331	2	-1.22	58.0	--	--	--	--
333	2	-1.09	--	--	58.4	--	--
334	0	7.88	--	--	--	86.1	--

Table 12. Statistical summary of reported data for standard reference samples M-156 (major constituents) -- Continued

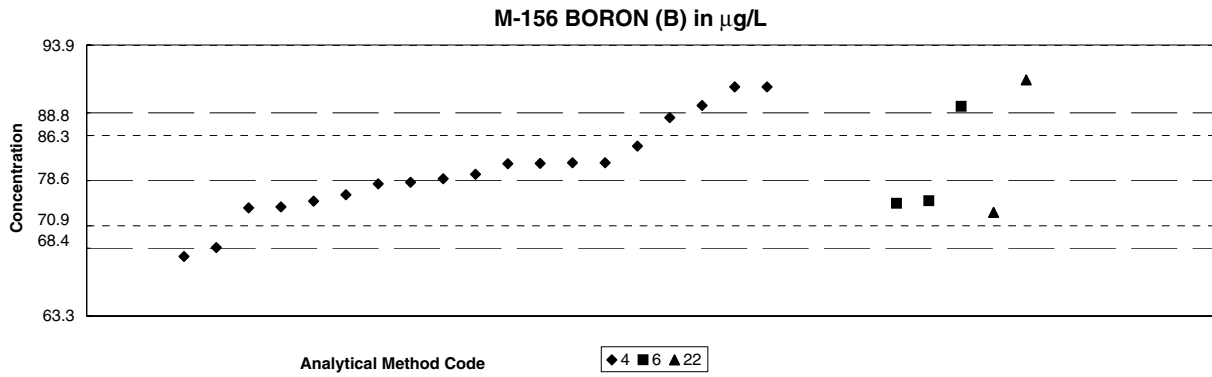

Summary	Methods			Method Codes	Statistics	
	4	6	22			
N =	21	3	2	4. Inductively coupled plasma	MPV =	78.6 µg/L
Minimum =	61.0	76.0	75.0	6. Inductively coupled plasma/mass spectrometry	F-pseudosigma =	5.11
Maximum =	89.2	87.0	90.0	22. Colorimetric	N =	26
Median =	78.8				Uh =	82.5
F-pseudosigma =	3.71				Lh =	75.6

Lab	Rating	Z-value	Methods		
			4	6	22
1	4	-0.46	76.3	--	--
24	4	-0.31	77.0	--	--
25	0	-3.44	61.0	--	--
42	4	-0.45	--	76.3	--
48	4	-0.51	--	76.0	--
50	4	0.39	80.6	--	--
57	0	2.07	89.2	--	--
86	3	0.76	82.5	--	--
105	NR	--	<200	--	--
127	3	-0.61	75.5	--	--
129	3	-0.70	--	--	75.0
134	4	0.38	80.5	--	--
138	2	1.39	85.7	--	--
142	4	0.37	80.5	--	--
180	NR	--	<21.9	--	--
212	4	0.14	79.3	--	--
220	4	-0.07	78.2	--	--
234	1	1.66	87.1	--	--
235	3	-0.59	75.6	--	--
247	4	-0.04	78.4	--	--
255	4	0.39	80.6	--	--
258	0	2.23	--	--	90.0
259	4	0.04	78.8	--	--
265	1	1.64	--	87.0	--
273	0	-3.34	61.5	--	--
309	2	-1.49	71.0	--	--
323	0	2.07	89.2	--	--
328	1	-1.68	70.0	--	--
331	NR	--	<80	--	--

Table 12. Statistical summary of reported data for standard reference samples M-156 (major constituents) -- Continued

M-156 CALCIUM (Ca) in mg/L

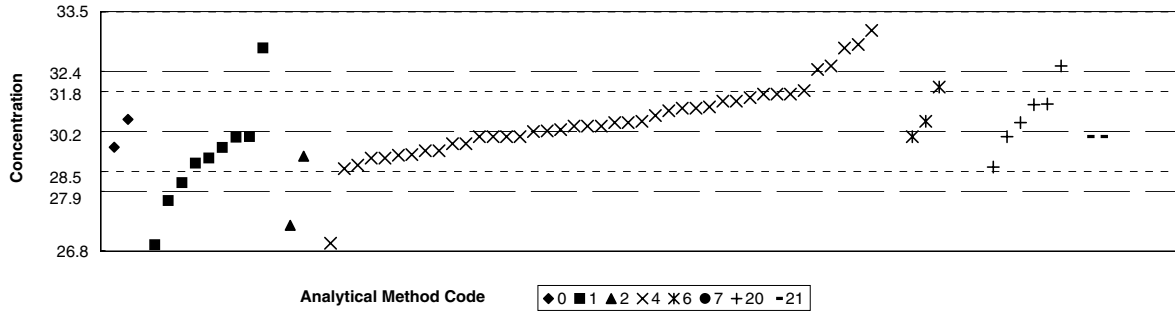

Summary	Methods								Method Codes	Statistics
	0	1	2	4	6	7	20	21		
N =	2	11	2	44	3	1	9	2	0. Other	MPV = 30.2 mg/L
Minimum =	29.7	23.4	27.5	6.30	30.0	13.2	23.1	30.0	1. Atomic absorption: direct, air	F-pseudostigma = 1.13
Maximum =	30.5	64.0	29.5	35.5	31.4	76.4	30.0		2. Atomic absorption: direct, nitrous oxide	Rating criterion = 1.51
Median =		29.4		30.4					4. Inductively coupled plasma	N = 74
F-pseudostigma =		1.14		1.00			1.32		6. Inductively coupled plasma/mass spectrometry	Uh = 31.0
									7. Ion chromatography	Lh = 29.5
									20. Titration: colorimetric	
									21. Titration: electrometric	

Lab	Rating	Z-value	Methods							
			0	1	2	4	6	7	20	21
1	4	0.18	--	--	--	30.4	--	--	--	--
10	4	-0.12	--	30.0	--	--	--	--	--	--
12	4	-0.10	--	--	--	30.0	--	--	--	--
13	3	0.69	--	--	--	31.2	--	--	--	--
23	0	30.67	--	--	--	--	--	--	76.4	--
24	4	-0.10	--	--	--	30.0	--	--	--	--
25	3	-0.63	--	--	--	29.2	--	--	--	--
38	4	-0.47	--	--	29.5	--	--	--	--	--
42	4	0.16	--	--	--	30.4	--	--	--	--
45	4	-0.31	--	29.7	--	--	--	--	--	--
48	3	0.83	--	--	--	31.4	--	--	--	--
50	4	0.00	--	--	--	30.2	--	--	--	--
57	4	-0.37	--	--	--	29.6	--	--	--	--
59	4	-0.10	--	--	--	30.0	--	--	--	--
64	4	0.43	--	--	--	30.8	--	--	--	--
69	3	-0.97	--	28.7	--	--	--	--	--	--
70	3	0.69	--	--	--	31.2	--	--	--	--
76	4	0.18	--	--	--	30.4	--	--	--	--
81	4	0.30	--	--	--	30.6	--	--	--	--
86	4	0.10	--	--	--	30.3	--	--	--	--
87	1	-1.76	--	--	27.5	--	--	--	--	--
89	2	-1.30	--	28.2	--	--	--	--	--	--
93	4	0.16	--	--	--	30.4	--	--	--	--
105	1	1.62	--	--	--	32.6	--	--	--	--
109	4	-0.50	--	29.4	--	--	--	--	--	--
113	4	-0.30	29.7	--	--	--	--	--	--	--
121	4	0.03	--	--	--	30.2	--	--	--	--
127	3	0.76	--	--	--	31.3	--	--	--	--
129	4	-0.10	--	30.0	--	--	--	--	--	--
134	4	0.00	--	--	--	30.2	--	--	--	--
138	4	-0.24	--	--	--	29.8	--	--	--	--
140	3	-0.60	--	29.3	--	--	--	--	--	--
142	1	1.56	--	--	--	32.5	--	--	--	--
154	3	0.69	--	--	--	31.2	--	--	--	--
155	4	0.51	--	--	--	--	--	--	30.9	--
180	0	-15.82	--	--	--	6.3	--	--	--	--
190	1	1.56	--	32.5	--	--	--	--	--	--
193	3	-0.70	--	--	--	29.1	--	--	--	--
203	4	-0.45	--	--	--	29.5	--	--	--	--
212	4	0.10	--	--	--	30.3	--	--	--	--
215	1	1.89	--	--	--	33.0	--	--	--	--
220	4	0.38	--	--	--	30.7	--	--	--	--
230	4	0.45	--	--	--	30.8	--	--	--	--
234	4	-0.24	--	--	--	29.8	--	--	--	--
235	4	-0.50	--	--	--	29.4	--	--	--	--
247	4	-0.10	--	--	--	30.0	--	--	--	--
254	3	0.63	--	--	--	31.1	--	--	--	--
255	4	0.10	--	--	--	30.3	--	--	--	--
257	4	0.16	--	--	--	--	--	--	30.4	--
258	0	-4.65	--	--	--	--	--	--	23.1	--

Lab	Rating	Z-value	Methods							
			0	1	2	4	6	7	20	21
259	4	-0.10	--	--	--	30.0	--	--	--	--
261	0	22.45	--	64.0	--	--	--	--	--	--
263	4	-0.10	--	--	--	--	--	--	30.0	--
265	4	0.43	--	--	--	30.8	--	--	--	--
266	4	-0.10	--	--	--	--	--	--	--	30.0
267	4	0.49	--	--	--	--	--	--	30.9	--
268	0	-2.13	--	27.0	--	--	--	--	--	--
270	0	-11.27	--	--	--	--	--	13.2	--	--
273	3	0.56	--	--	--	31.0	--	--	--	--
274	3	-0.67	--	--	--	--	--	--	29.1	--
275	2	1.22	--	--	--	--	--	--	32.0	--
277	2	1.16	--	--	--	31.9	--	--	--	--
279	0	-4.12	--	--	--	--	--	--	24.0	--
280	4	-0.10	--	--	--	--	--	--	--	30.0
287	4	0.22	30.5	--	--	--	--	--	--	--
297	0	-2.09	--	--	--	27.0	--	--	--	--
305	4	-0.43	--	--	--	29.5	--	--	--	--
309	0	2.75	--	--	--	34.3	--	--	--	--
315	4	-0.37	--	--	--	29.6	--	--	--	--
323	4	-0.50	--	--	--	29.4	--	--	--	--
324	0	-4.48	--	23.4	--	--	--	--	--	--
328	3	0.56	--	--	--	31.0	--	--	--	--
331	0	3.55	--	--	--	35.5	--	--	--	--
334	2	1.22	--	--	--	32.0	--	--	--	--

Table 12. Statistical summary of reported data for standard reference samples M-156 (major constituents) -- Continued

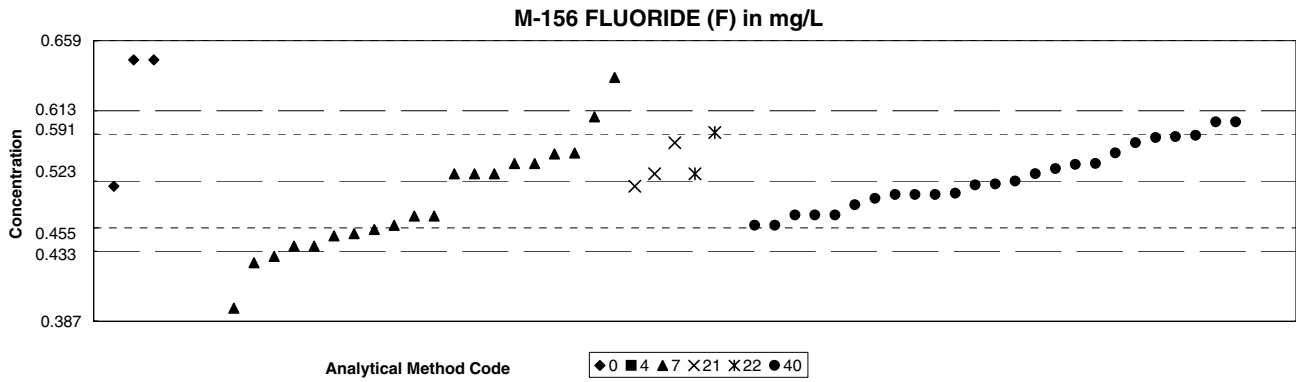

Summary	Methods						Method Codes	Statistics	
	0	4	7	21	22	40		MPV =	F-pseudosigma =
N =	3	1	22	3	3	25	0. Other	0.523 mg/L	
Minimum =	0.518	0.730	0.155	0.518	0.530	0.480	4. Inductively coupled plasma	0.045	
Maximum =	0.640		0.623	0.560	0.734	0.580	7. Ion chromatography	N = 57	
Median =			0.485			0.520	21. Titration: electrometric	Uh = 0.550	
F-pseudosigma =			0.059			0.033	22. Colorimetric	Lh = 0.489	
							40. Ion selective electrode		

Lab	Rating	Z-value	Methods					
			0	4	7	21	22	40
1	4	-0.27	--	--	--	--	--	0.511
10	4	-0.29	--	--	--	--	--	0.510
13	2	-1.39	--	--	0.460	--	--	--
18	4	-0.51	--	--	--	--	--	0.500
23	4	0.38	--	--	0.540	--	--	--
24	4	0.38	--	--	--	--	--	0.540
25	4	0.15	--	--	0.530	--	--	--
42	1	-1.75	--	--	0.444	--	--	--
45	2	-1.13	--	--	0.472	--	--	--
50	4	0.00	--	--	--	--	--	0.523
55	3	0.82	--	--	--	0.560	--	--
57	3	-0.73	--	--	--	--	--	0.490
59	4	0.15	--	--	0.530	--	--	--
69	4	0.15	--	--	0.530	--	--	--
70	2	1.26	--	--	--	--	--	0.580
81	3	-0.75	--	--	0.489	--	--	--
86	2	1.37	--	--	0.585	--	--	--
89	2	1.26	--	--	--	--	--	0.580
93	3	-0.75	--	--	0.489	--	--	--
96	4	-0.09	--	--	--	--	--	0.519
97	4	-0.11	--	--	--	0.518	--	--
105	3	-0.95	--	--	0.480	--	--	--
107	3	0.93	--	--	--	--	--	0.565
109	3	-0.95	--	--	--	--	--	0.480
113	4	-0.11	0.518	--	--	--	--	--
114	3	0.82	--	--	--	--	--	0.560
127	2	-1.04	--	--	0.476	--	--	--
131	1	-1.61	--	--	0.450	--	--	--
134	3	-0.73	--	--	--	--	--	0.490
138	4	0.27	--	--	--	--	--	0.535
140	3	0.95	--	--	--	--	--	0.566
142	3	0.60	--	--	--	--	--	0.550
154	3	0.97	--	--	--	--	--	0.567
180	0	-8.14	--	--	0.155	--	--	--
183	0	2.59	0.640	--	--	--	--	--
190	4	0.35	--	--	--	--	--	0.539
212	4	0.15	--	--	--	0.530	--	--
215	4	-0.07	--	--	--	--	--	0.520
230	0	4.58	--	0.730	--	--	--	--
234	3	0.57	--	--	0.549	--	--	--
247	0	-2.72	--	--	0.400	--	--	--
255	4	-0.38	--	--	--	--	--	0.506
257	4	-0.29	--	--	--	--	--	0.510
258	0	4.67	--	--	--	--	0.734	--
259	4	0.15	--	--	--	--	--	0.530
263	3	-0.73	--	--	--	--	--	0.490
265	2	-1.17	--	--	0.470	--	--	--
266	4	-0.29	--	--	--	--	--	0.510
270	0	-4.71	--	--	0.310	--	--	--
273	0	2.21	--	--	0.623	--	--	--

Lab	Rating	Z-value	Methods					
			0	4	7	21	22	40
274	2	1.04	--	--	--	--	--	0.570
277	2	-1.39	--	--	0.460	--	--	--
287	4	0.38	--	--	0.540	--	--	--
305	3	-0.95	--	--	--	--	--	0.480
323	4	0.15	--	--	--	--	--	0.530
328	0	2.59	0.640	--	--	--	--	--
331	3	0.60	--	--	0.550	--	--	--

Table 12. Statistical summary of reported data for standard reference samples M-156 (major constituents) -- Continued

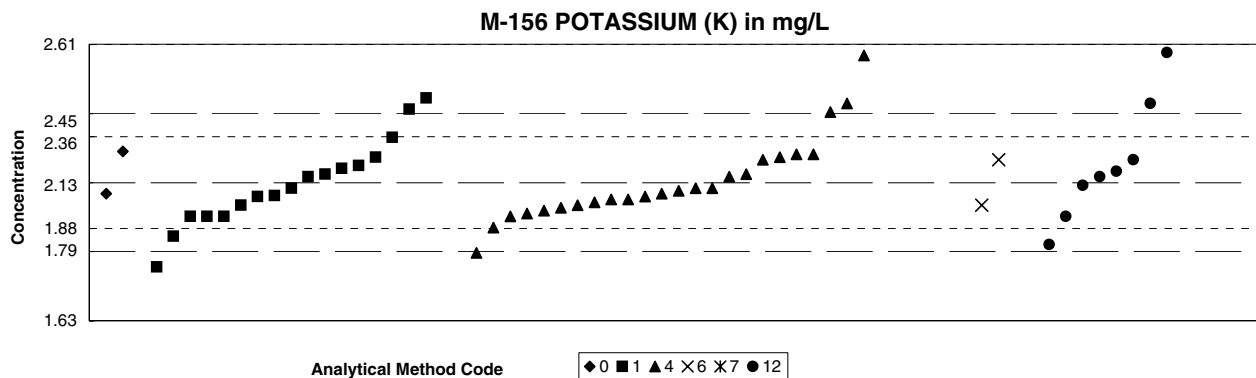

Summary	Methods						Statistics
	0	1	4	6	7	12	
N =	2	19	31	2	1	9	MPV = 2.13 mg/L
Minimum =	2.08	0.31	0.86	2.04	14.66	1.45	F-pseudostigma = 0.163
Maximum =	2.23	2.87	5.00	2.20		2.58	N = 64
Median =		2.10	2.10			2.14	Uh = 2.26
F-pseudostigma =		0.145	0.252			0.148	Lh = 2.04
	Method Codes 0. Other 1. Atomic absorption: direct, air 4. Inductively coupled plasma 6. Inductively coupled plasma/mass spectrometry 7. Ion chromatography 12. Flame emission						

Lab	Rating	Z-value	Methods					
			0	1	4	6	7	12
1	4	0.28	--	2.17	--	--	--	--
10	4	-0.34	--	2.07	--	--	--	--
13	4	-0.15	--	--	2.10	--	--	--
23	2	-1.38	--	--	--	--	1.90	--
24	3	-0.64	--	--	2.02	--	--	--
25	3	-0.71	--	--	2.01	--	--	--
38	4	0.34	--	2.18	--	--	--	--
42	3	-0.52	--	--	2.04	--	--	--
45	1	-1.87	--	1.82	--	--	--	--
48	3	-0.52	--	--	--	2.04	--	--
50	4	-0.40	--	--	2.06	--	--	--
57	0	6.53	--	--	3.19	--	--	--
59	4	0.46	--	--	--	2.20	--	--
64	4	-0.15	--	2.10	--	--	--	--
69	4	0.09	--	--	--	--	--	2.14
70	4	0.09	--	--	2.14	--	--	--
81	3	0.58	--	--	2.22	--	--	--
86	4	0.15	--	--	2.15	--	--	--
87	3	0.52	--	2.21	--	--	--	--
89	2	-1.20	--	1.93	--	--	--	--
93	4	-0.21	--	--	2.09	--	--	--
105	4	-0.34	--	--	2.07	--	--	--
109	4	0.09	--	2.14	--	--	--	--
113	4	-0.28	2.08	--	--	--	--	--
127	4	0.15	--	2.15	--	--	--	--
129	3	-0.77	--	--	2.00	--	--	--
134	4	-0.31	--	2.07	--	--	--	--
138	3	-0.58	--	--	2.03	--	--	--
140	3	-0.77	--	2.00	--	--	--	--
142	4	-0.28	--	--	2.08	--	--	--
180	0	-7.78	--	--	0.86	--	--	--
190	0	4.57	--	--	2.87	--	--	--
193	3	-0.52	--	2.04	--	--	--	--
203	4	0.21	--	--	--	--	2.16	--
212	2	1.50	--	--	2.37	--	--	--
220	3	0.95	--	2.28	--	--	--	--
230	0	4.26	--	--	2.82	--	--	--
234	2	-1.01	--	--	1.96	--	--	--
235	4	-0.46	--	--	2.05	--	--	--
247	4	-0.40	--	--	2.06	--	--	--
254	3	0.52	--	--	2.21	--	--	--
257	3	-0.77	--	--	--	--	2.00	--
258	0	2.79	--	--	--	--	2.58	--
259	1	-1.56	--	--	1.87	--	--	--
261	0	-11.13	--	0.31	--	--	--	--
265	4	-0.15	--	--	2.10	--	--	--
266	4	0.46	--	--	--	--	2.20	--
268	1	1.81	--	2.42	--	--	--	--
270	0	76.86	--	--	--	14.66	--	--
273	4	0.46	--	--	2.20	--	--	--

Lab	Rating	Z-value	Methods					
			0	1	4	6	7	12
274	4	-0.09	--	--	--	--	--	2.11
275	1	1.69	--	--	--	--	--	2.40
276	3	-0.77	--	2.00	--	--	--	--
277	0	2.73	--	--	2.57	--	--	--
279	0	-4.14	--	--	--	--	--	1.45
287	3	0.64	2.23	--	--	--	--	--
297	0	6.59	--	--	3.20	--	--	--
305	0	4.02	--	--	2.78	--	--	--
306	1	1.56	--	2.38	--	--	--	--
309	0	17.63	--	--	5.00	--	--	--
315	1	1.69	--	--	2.40	--	--	--
323	3	0.58	--	--	2.22	--	--	--
328	3	-0.77	--	--	2.00	--	--	--
331	0	5.06	--	--	2.95	--	--	--

Table 12. Statistical summary of reported data for standard reference samples M-156 (major constituents) -- Continued

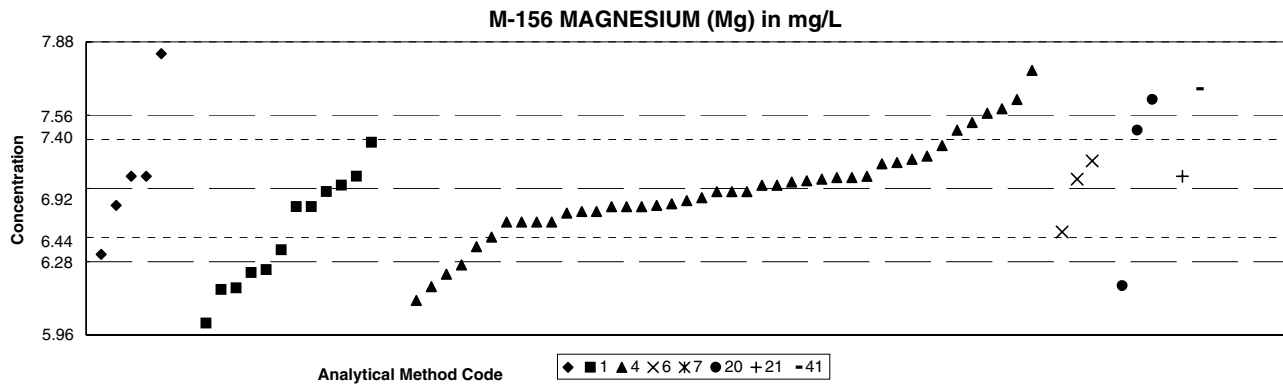

Summary	Methods								Statistics	
	0	1	4	6	7	20	21	41		
N =	7	13	44	3	1	4	1	1	Method Codes 0. Other 1. Atomic absorption: direct, air 4. Inductively coupled plasma 6. Inductively coupled plasma/mass spectrometry 7. Ion chromatography 20. Titration: colorimetric 21. Titration: electrometric 41. Electrometric [pH and specific conductance]	MPV = 6.92 mg/L F-pseudosigma = 0.319 Rating criterion = 0.346 N = 74 Uh = 7.13 Lh = 6.70
Minimum =	6.49	6.04	1.22	6.64	14.68	6.29	7.00	7.57		
Maximum =	13.46	46.40	7.96	7.10		18.94				
Median =	7.00	6.80	6.90							
F-pseudosigma =	0.701	0.423	0.263							

Lab	Rating	Z-value	Methods							
			0	1	4	6	7	20	21	41
1	4	0.14	--	--	6.97	--	--	--	--	--
10	4	0.06	--	6.94	--	--	--	--	--	--
12	3	0.55	--	--	7.11	--	--	--	--	--
13	3	0.81	--	--	7.20	--	--	--	--	--
23	4	-0.06	--	6.90	--	--	--	--	--	--
24	4	-0.43	--	--	6.77	--	--	--	--	--
25	4	0.06	--	--	6.94	--	--	--	--	--
38	1	-1.88	--	6.27	--	--	--	--	--	--
42	4	-0.17	--	--	6.86	--	--	--	--	--
45	1	-1.91	--	6.26	--	--	--	--	--	--
48	4	0.17	--	--	6.98	--	--	--	--	--
50	4	0.12	--	--	6.96	--	--	--	--	--
57	4	0.06	--	--	6.94	--	--	--	--	--
59	3	0.52	--	--	7.10	--	--	--	--	--
64	3	-0.64	--	--	6.70	--	--	--	--	--
69	1	-1.53	--	6.39	--	--	--	--	--	--
70	4	0.23	--	--	7.00	--	--	--	--	--
76	3	-0.82	--	--	6.64	--	--	--	--	--
81	4	0.20	--	--	6.99	--	--	--	--	--
86	4	0.49	--	--	7.09	--	--	--	--	--
87	1	-1.59	--	6.37	--	--	--	--	--	--
89	0	-2.54	--	6.04	--	--	--	--	--	--
93	2	-1.45	--	--	6.42	--	--	--	--	--
105	4	-0.23	--	--	6.84	--	--	--	--	--
109	4	0.23	--	7.00	--	--	--	--	--	--
113	4	-0.32	6.81	--	--	--	--	--	--	--
121	3	-0.64	--	--	6.70	--	--	--	--	--
127	2	1.42	--	--	7.41	--	--	--	--	--
129	4	-0.35	--	6.80	--	--	--	--	--	--
134	3	-0.92	--	--	6.60	--	--	--	--	--
138	3	-0.64	--	--	6.70	--	--	--	--	--
140	4	-0.35	--	6.80	--	--	--	--	--	--
142	2	1.50	--	--	7.44	--	--	--	--	--
154	4	-0.35	--	--	6.80	--	--	--	--	--
155	1	-1.83	--	--	--	--	6.29	--	--	--
180	0	-16.47	--	--	1.22	--	--	--	--	--
190	3	0.87	--	7.22	--	--	--	--	--	--
193	4	-0.32	--	--	6.81	--	--	--	--	--
203	1	-1.62	--	--	6.36	--	--	--	--	--
212	4	0.17	--	--	6.98	--	--	--	--	--
215	1	1.68	--	--	7.50	--	--	--	--	--
220	2	-1.10	--	--	6.54	--	--	--	--	--
230	0	-2.11	--	--	6.19	--	--	--	--	--
234	4	-0.35	--	--	6.80	--	--	--	--	--
235	1	-1.85	--	--	6.28	--	--	--	--	--
247	3	-0.64	--	--	6.70	--	--	--	--	--
254	3	0.61	--	--	7.13	--	--	--	--	--
255	4	-0.29	--	--	6.82	--	--	--	--	--
256	0	2.83	7.90	--	--	--	--	--	--	--
257	4	0.23	--	--	--	--	--	7.00	--	--

Lab	Rating	Z-value	Methods							
			0	1	4	6	7	20	21	41
258	0	18.90	13.46	--	--	--	--	--	--	--
259	4	-0.43	--	--	6.77	--	--	--	--	--
261	0	114.10	--	46.40	--	--	--	--	--	--
263	4	0.23	7.00	--	--	--	--	--	--	--
265	4	-0.06	--	--	6.90	--	--	--	--	--
266	4	0.23	7.00	--	--	--	--	--	--	--
267	2	1.10	--	--	--	--	--	7.30	--	--
268	2	-1.16	--	6.52	--	--	--	--	--	--
270	0	22.43	--	--	--	--	--	14.68	--	--
273	2	1.10	--	--	7.30	--	--	--	--	--
274	1	1.88	--	--	--	--	--	--	--	7.57
275	1	1.68	--	--	--	--	--	7.50	--	--
277	2	1.24	--	--	7.35	--	--	--	--	--
279	0	34.74	--	--	--	--	--	18.94	--	--
280	0	2.54	7.80	--	--	--	--	--	--	--
287	2	-1.24	6.49	--	--	--	--	--	--	--
297	0	2.23	--	--	7.69	--	--	--	--	--
305	4	0.20	--	--	6.99	--	--	--	--	--
309	4	-0.06	--	--	6.90	--	--	--	--	--
315	4	-0.35	--	--	6.80	--	--	--	--	--
323	4	-0.46	--	--	6.76	--	--	--	--	--
328	4	-0.06	--	--	6.90	--	--	--	--	--
331	0	3.01	--	--	7.96	--	--	--	--	--
334	4	0.46	--	--	7.08	--	--	--	--	--

Table 12. Statistical summary of reported data for standard reference samples M-156 (major constituents) -- Continued

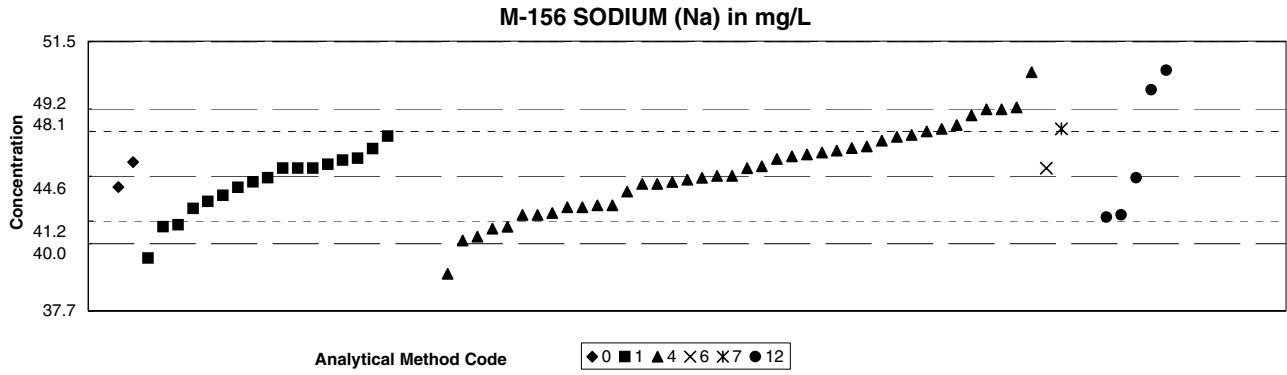

Summary	Methods						Statistics
	0	1	4	6	7	12	
N =	3	19	41	1	1	7	MPV = 44.6 mg/L
Minimum =	34.8	40.4	37.3	45.0	47.0	28.5	F-pseudostigma = 2.30
Maximum =	45.3	56.9	49.9			50.0	N = 72
Median =		45.0	44.6			42.6	Uh = 46.1
F-pseudostigma =		1.48	2.52			5.89	Lh = 43.0

Methods	
Method Codes	
0.	Other
1.	Atomic absorption: direct, air
4.	Inductively coupled plasma
6.	Inductively coupled plasma/mass spectrometry
7.	Ion chromatography
12.	Flame emission

Lab	Rating	Z-value	Methods					
			0	1	4	6	7	12
1	3	0.62	--	--	46.0	--	--	--
10	4	-0.25	--	44.0	--	--	--	--
12	3	0.57	--	--	45.9	--	--	--
13	3	0.52	--	--	45.8	--	--	--
23	1	-1.83	--	40.4	--	--	--	--
24	4	0.22	--	--	45.1	--	--	--
25	3	-0.70	--	--	43.0	--	--	--
38	3	-0.73	--	42.9	--	--	--	--
42	4	0.00	--	--	44.6	--	--	--
45	2	-1.09	--	42.1	--	--	--	--
48	4	0.17	--	--	--	45.0	--	--
50	3	0.99	--	--	46.9	--	--	--
57	3	-0.65	--	--	43.1	--	--	--
59	4	0.35	--	45.4	--	--	--	--
64	4	0.26	--	45.2	--	--	--	--
69	3	-0.87	--	--	--	--	42.6	--
70	2	1.48	--	--	48.0	--	--	--
81	2	1.13	--	--	47.2	--	--	--
86	3	0.65	--	--	46.1	--	--	--
87	4	-0.44	--	43.6	--	--	--	--
89	3	-0.57	--	43.3	--	--	--	--
93	1	1.52	--	--	48.1	--	--	--
105	3	0.87	--	--	46.6	--	--	--
109	4	-0.13	--	44.3	--	--	--	--
113	4	0.30	45.3	--	--	--	--	--
118	4	0.17	--	45.0	--	--	--	--
121	4	-0.04	--	--	44.5	--	--	--
127	2	-1.44	--	--	41.3	--	--	--
129	4	0.17	--	45.0	--	--	--	--
134	3	0.88	--	46.6	--	--	--	--
138	4	-0.09	--	--	44.4	--	--	--
140	2	-1.13	--	42.0	--	--	--	--
142	0	2.31	--	--	49.9	--	--	--
154	3	-0.87	--	--	42.6	--	--	--
180	0	-2.18	--	--	39.6	--	--	--
190	3	0.61	--	46.0	--	--	--	--
193	4	-0.17	--	--	44.2	--	--	--
203	3	-0.87	--	--	42.6	--	--	--
212	2	1.04	--	--	47.0	--	--	--
215	2	1.48	--	--	48.0	--	--	--
220	4	0.44	--	--	45.6	--	--	--
230	4	0.38	--	--	45.5	--	--	--
234	4	0.00	--	--	44.6	--	--	--
235	2	-1.13	--	--	42.0	--	--	--
247	4	-0.17	--	--	44.2	--	--	--
254	3	0.91	--	--	46.7	--	--	--
256	0	-4.27	34.8	--	--	--	--	--
257	3	-0.91	--	--	--	--	42.5	--
258	0	-4.14	--	--	--	--	35.1	--
259	4	-0.13	--	--	44.3	--	--	--

Lab	Rating	Z-value	Methods					
			0	1	4	6	7	12
261	4	0.17	--	45.0	--	--	--	--
265	4	0.48	--	--	45.7	--	--	--
266	4	-0.04	--	--	--	--	--	44.5
268	4	0.39	--	45.5	--	--	--	--
270	2	1.04	--	--	--	--	47.0	--
273	3	0.78	--	--	46.4	--	--	--
274	0	2.35	--	--	--	--	--	50.0
275	1	1.92	--	--	--	--	--	49.0
276	0	3.44	--	52.5	--	--	--	--
277	2	-1.18	--	--	41.9	--	--	--
279	0	-7.01	--	--	--	--	--	28.5
287	4	-0.25	44.0	--	--	--	--	--
297	3	-0.70	--	--	43.0	--	--	--
305	0	-3.18	--	--	37.3	--	--	--
306	0	5.35	--	56.9	--	--	--	--
307	4	-0.04	--	44.5	--	--	--	--
309	3	-0.83	--	--	42.7	--	--	--
315	3	-0.65	--	--	43.1	--	--	--
323	4	-0.35	--	--	43.8	--	--	--
328	4	0.17	--	--	45.0	--	--	--
331	2	-1.35	--	--	41.5	--	--	--
334	2	1.35	--	--	47.7	--	--	--

Table 12. Statistical summary of reported data for standard reference samples M-156 (major constituents) -- Continued

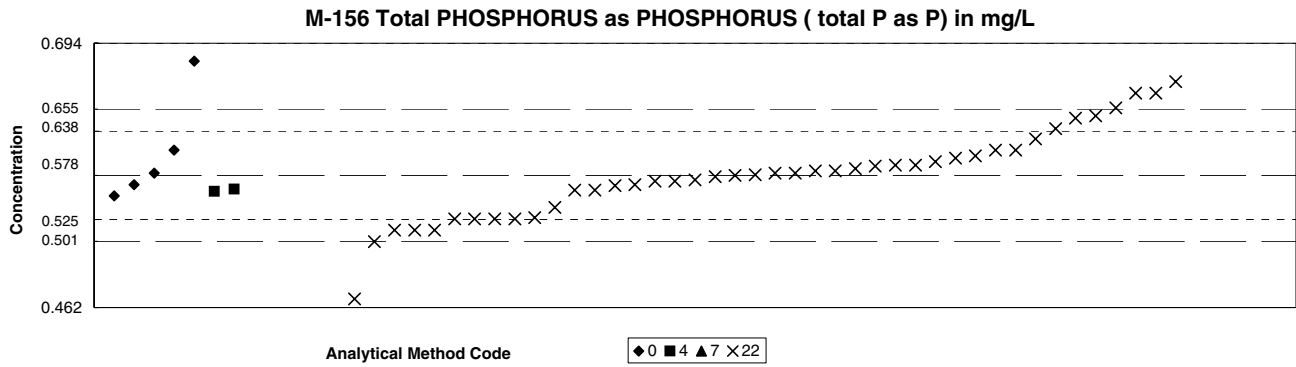

Summary	Methods				Statistics
	0	4	7	22	
N =	5	2	2	46	MPV = 0.578 mg/L F-pseudostigma = 0.039 N = 55 Uh = 0.598 Lh = 0.546
Minimum =	0.560	0.564	0.450	0.200	
Maximum =	0.678	0.566	4.710	0.700	
Median =	0.580			0.578	
F-pseudostigma =	0.022			0.041	

Lab	Rating	Z-value	Methods			
			0	4	7	22
12	4	-0.34	--	--	--	0.565
13	0	-2.80	--	--	--	0.470
18	4	-0.47	0.560	--	--	--
23	0	2.13	--	--	--	0.660
25	3	-0.99	--	--	--	0.540
38	2	-1.25	--	--	--	0.530
42	4	-0.36	--	0.564	--	--
45	4	-0.03	--	--	--	0.577
48	1	1.87	--	--	--	0.650
50	4	0.10	--	--	--	0.582
51	4	-0.23	--	--	--	0.569
55	4	-0.13	--	--	--	0.573
57	2	-1.50	--	--	--	0.520
64	0	-3.32	--	--	--	0.450
70	0	3.16	--	--	--	0.700
81	2	-1.25	--	--	--	0.530
86	4	-0.31	--	0.566	--	--
87	4	0.21	--	--	--	0.586
89	4	-0.13	--	--	--	0.573
97	2	-1.25	--	--	--	0.530
105	3	-0.73	--	--	--	0.550
113	4	-0.10	--	--	--	0.574
118	3	0.83	--	--	--	0.610
127	4	0.10	--	--	--	0.582
129	4	0.31	--	--	--	0.590
131	0	-3.32	--	0.450	--	--
134	4	0.39	--	--	--	0.593
138	4	0.23	--	--	--	0.587
140	3	0.57	--	--	--	0.600
142	1	1.53	--	--	--	0.637
154	2	1.30	--	--	--	0.628
155	4	0.02	--	--	--	0.579
180	0	-9.81	--	--	--	0.200
183	4	0.05	0.580	--	--	--
190	4	-0.34	--	--	--	0.565
203	3	-0.99	--	--	--	0.540
212	0	-3.84	--	--	--	0.430
213	3	-0.99	--	--	--	0.540
215	4	0.05	--	--	--	0.580
220	4	0.44	--	--	--	0.595
234	1	1.87	--	--	--	0.650
247	3	-0.96	--	--	--	0.541
257	4	0.05	--	--	--	0.580
259	3	-0.99	--	--	--	0.540
267	3	0.57	--	--	--	0.600
270	0	107.19	--	4.710	--	--
273	4	-0.21	--	--	--	0.570
274	2	1.35	--	--	--	0.630
297	2	1.06	--	--	--	0.619
305	4	0.23	--	--	--	0.587

Lab	Rating	Z-value	Methods			
			0	4	7	22
306	0	2.59	0.678	--	--	--
307	4	0.00	--	--	--	0.578
323	4	0.16	--	--	--	0.584
328	3	0.57	0.600	--	--	--
331	4	-0.21	0.570	--	--	--

Table 12. Statistical summary of reported data for standard reference samples M-156 (major constituents) -- Continued

M-156 pH

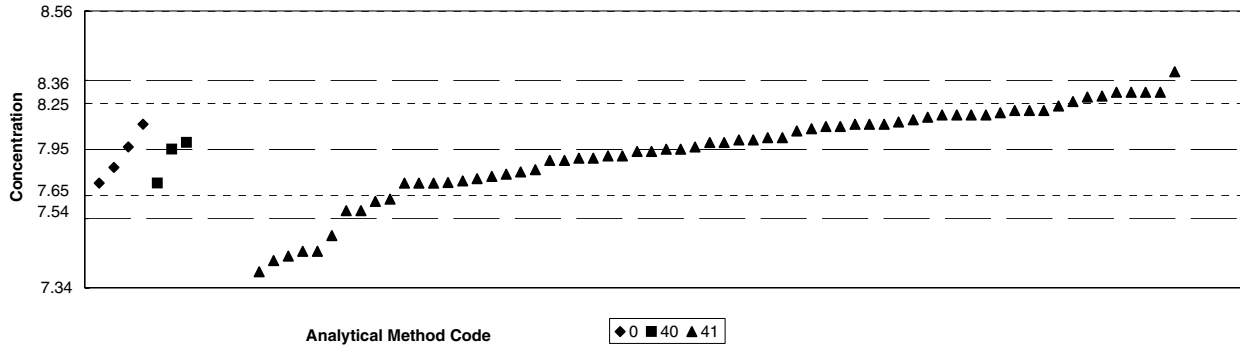

Summary	Methods			Method Codes	Statistics
	0	40	41		
N =	4	3	68	0. Other	MPV = 7.95
Minimum =	7.80	7.80	2.50	40. Ion selective electrode	F-pseudosigma = 0.203
Maximum =	8.06	7.98	8.29	41. Electrometric [pH and specific conductance]	Rating criterion= 0.398
Median =			7.96		N = 75
F-pseudosigma =			0.218		Uh = 8.08
					Lh = 7.80

Lab	Rating	Z-value	Methods		
			0	40	41
1	0	-2.68	--	--	6.89
10	4	0.43	--	--	8.12
12	3	-0.68	--	--	7.68
13	4	0.38	--	--	8.10
23	4	0.20	--	--	8.03
24	4	-0.25	--	--	7.85
25	4	-0.08	--	--	7.92
38	4	0.38	--	--	8.10
42	4	-0.10	--	--	7.91
45	3	0.86	--	--	8.29
48	4	0.38	--	--	8.10
50	4	-0.08	--	--	7.92
51	4	0.08	--	--	7.98
57	4	-0.13	--	--	7.90
59	0	-4.65	--	--	6.10
64	3	0.53	--	--	8.16
69	2	-1.18	--	--	7.48
70	4	0.10	--	--	7.99
76	3	0.59	--	--	8.18
81	4	0.28	--	--	8.06
86	4	0.10	--	--	7.99
87	4	0.23	--	--	8.04
89	4	0.25	--	--	8.05
93	4	0.00	--	7.95	--
96	4	-0.33	--	--	7.82
97	4	0.30	--	--	8.07
105	4	0.13	--	--	8.00
109	2	-1.36	--	--	7.41
113	4	-0.20	7.87	--	--
114	4	-0.03	--	--	7.94
118	4	-0.38	--	--	7.80
127	3	0.58	--	--	8.18
129	2	-1.23	--	--	7.46
134	4	-0.37	--	--	7.80
138	4	0.28	--	--	8.06
140	0	-2.29	--	--	7.04
142	2	-1.13	--	--	7.50
154	4	0.35	--	--	8.09
155	4	-0.30	--	--	7.83
180	0	-13.71	--	--	2.50
190	4	-0.23	--	--	7.86
203	4	0.28	--	--	8.06
212	3	0.63	--	--	8.20
213	4	0.00	--	--	7.95
215	4	0.00	--	--	7.95
230	3	0.63	--	--	8.20
234	4	0.33	--	--	8.08
243	4	-0.10	--	--	7.91
247	4	0.40	--	--	8.11
256	4	0.03	7.96	--	--

Lab	Rating	Z-value	Methods		
			0	40	41
257	4	-0.13	--	--	7.90
258	3	-0.68	--	--	7.68
259	4	0.48	--	--	8.14
261	4	0.03	--	--	7.96
263	4	0.25	--	--	8.05
266	4	0.43	--	--	8.12
267	4	0.38	--	--	8.10
268	3	-0.55	--	--	7.73
273	4	0.08	--	7.98	--
274	3	-0.96	--	--	7.57
276	4	-0.03	--	--	7.94
277	4	-0.35	--	--	7.81
279	2	-1.13	--	--	7.50
280	4	0.13	--	--	8.00
287	4	-0.28	--	--	7.84
297	4	0.28	8.06	--	--
305	3	0.63	--	--	8.20
306	4	-0.38	7.80	--	--
307	3	0.63	--	--	8.20
309	4	-0.38	--	--	7.80
323	4	-0.38	--	7.80	--
324	4	-0.38	--	--	7.80
328	3	-0.58	--	--	7.72
331	4	0.08	--	--	7.98
333	4	0.43	--	--	8.12

Table 12. Statistical summary of reported data for standard reference samples M-156 (major constituents) -- Continued

M-156 ROE (Residue on Evaporation) in mg/L

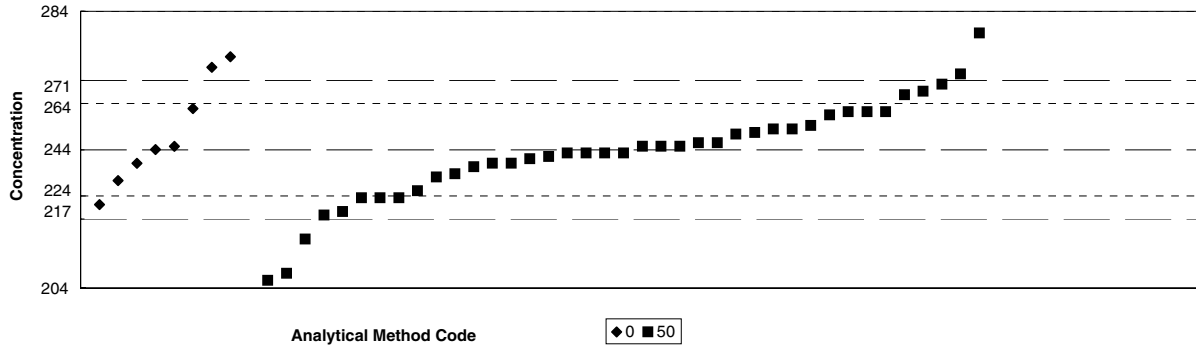

Summary	Methods		Statistics
	0	50	
N =	8	41	MPV = 244 mg/L
Minimum =	228	170	F-pseudosigma = 13
Maximum =	271	772	N = 49
Median =	245	243	Uh = 254
F-pseudosigma =	18	11	Lh = 236

Methods	
Method Codes	
0. Other	
50. Gravimetric	

Lab	Rating	Z-value	Methods	
			0	50
1	4	0.07	--	245
10	4	0.00	244	--
12	3	0.82	--	255
13	0	-2.83	--	206
18	1	1.79	268	--
23	1	-1.94	--	218
25	0	-5.52	--	170
45	2	-1.04	--	230
48	3	0.52	--	251
50	3	0.82	--	255
55	4	0.45	--	250
57	2	-1.04	--	230
59	4	-0.07	--	243
69	2	-1.19	228	--
70	1	1.64	--	266
76	4	-0.20	--	241
81	4	0.07	--	245
87	4	-0.15	--	242
89	4	-0.37	--	239
96	4	0.37	--	249
97	4	-0.07	--	243
105	0	39.4	--	772
109	4	-0.07	--	243
113	0	2.01	271	--
114	3	0.82	--	255
118	4	0.15	--	246
127	4	-0.07	--	243
129	3	-0.89	--	232
134	3	0.75	--	254
138	2	-1.34	--	226
140	2	-1.04	--	230
142	2	1.19	--	260
154	4	0.15	--	246
190	4	0.34	--	249
215	4	0.07	--	245
234	2	1.27	--	261
247	0	-2.68	--	208
257	4	0.45	--	250
258	3	-0.60	--	236
259	4	-0.30	--	240
263	3	-0.52	--	237
266	4	-0.30	240	--
273	4	-0.30	--	240
275	3	-0.67	235	--
276	4	0.07	245	--
277	2	-1.42	--	225
324	0	2.53	--	278
328	2	1.42	--	263
331	3	0.89	256	--

Table 12. Statistical summary of reported data for standard reference samples M-156 (major constituents) -- Continued

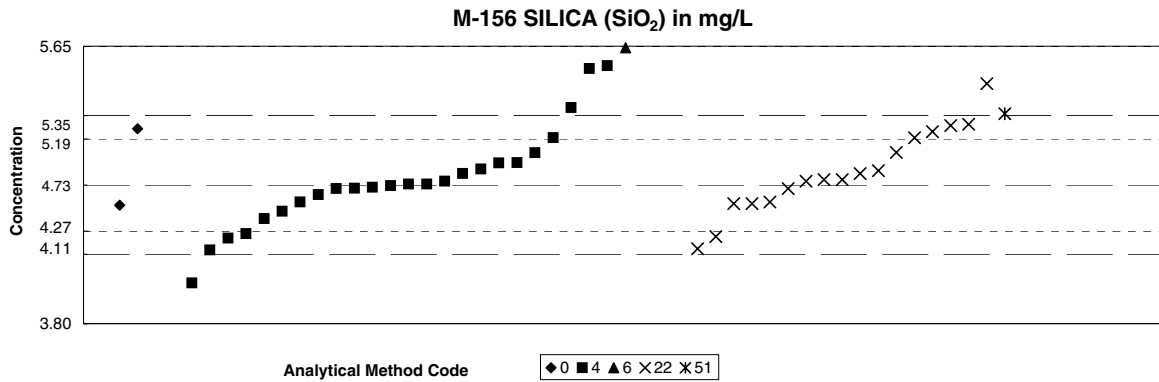

Summary	Methods					Statistics
	0	4	6	22	51	
N =	3	26	1	20	1	MPV = 4.73 mg/L
Minimum =	3.78	2.34	5.64	2.30	5.20	F-pseudostigma = 0.308
Maximum =	5.10	5.52		5.40		N = 51
Median =		4.72		4.76		Uh = 4.94
F-pseudostigma =		0.276		0.371		Lh = 4.53

Methods	Method Codes				
	0	4	6	22	51
0. Other					
4. Inductively coupled plasma					
6. Inductively coupled plasma/mass spectrometry					
22. Colorimetric					
51. Turbidimetric					

Lab	Rating	Z-value	Methods				
			0	4	6	22	51
1	4	0.46	--	4.87	--	--	--
10	4	-0.42	--	--	--	4.60	--
13	4	-0.10	--	4.70	--	--	--
18	4	0.06	--	--	--	4.75	--
23	3	1.01	--	--	--	5.04	--
24	3	1.01	--	5.04	--	--	--
25	2	-1.43	--	4.29	--	--	--
38	4	0.10	--	--	--	4.76	--
42	0	-2.14	--	4.07	--	--	--
50	4	0.46	--	4.87	--	--	--
57	3	-0.58	--	4.55	--	--	--
59	2	-1.17	--	4.37	--	--	--
64	4	0.00	--	4.73	--	--	--
70	2	1.14	--	--	--	5.08	--
87	4	0.10	--	--	--	4.76	--
89	4	0.23	--	--	--	4.80	--
93	2	-1.14	--	--	--	4.38	--
97	4	-0.45	4.59	--	--	--	--
105	4	-0.06	--	4.71	--	--	--
113	2	1.20	5.10	--	--	--	--
118	0	-7.89	--	--	--	2.30	--
121	4	0.06	--	4.75	--	--	--
127	1	1.66	--	5.24	--	--	--
134	4	-0.09	--	4.70	--	--	--
138	4	0.29	--	--	--	4.82	--
140	4	-0.10	--	--	--	4.70	--
142	0	2.56	--	5.52	--	--	--
154	4	0.23	--	4.80	--	--	--
155	3	0.69	--	--	--	4.94	--
190	0	2.18	--	--	--	5.40	--
193	2	1.27	--	--	--	5.12	--
203	4	-0.39	--	--	--	4.61	--
204	2	1.30	--	--	--	5.13	--
212	0	-7.76	--	2.34	--	--	--
234	4	-0.03	--	4.72	--	--	--
235	4	-0.39	--	4.61	--	--	--
247	4	-0.42	--	--	--	4.60	--
254	3	0.68	--	4.94	--	--	--
256	0	-3.08	3.78	--	--	--	--
259	4	0.32	--	4.83	--	--	--
263	1	1.53	--	--	--	5.20	--
265	3	-0.75	--	4.50	--	--	--
266	2	-1.40	--	--	--	4.30	--
273	2	-1.07	--	4.40	--	--	--
274	0	-4.12	--	--	--	3.46	--
297	0	-5.32	--	--	--	3.09	--
309	0	-5.62	--	3.00	--	--	--
323	4	-0.23	--	4.66	--	--	--
328	0	2.95	--	--	5.64	--	--
331	0	2.50	--	5.50	--	--	--

Lab	Rating	Z-value	Methods				
			0	4	6	22	51
333	4	0.00	--	4.73	--	--	--

Table 12. Statistical summary of reported data for standard reference samples M-156 (major constituents) -- Continued

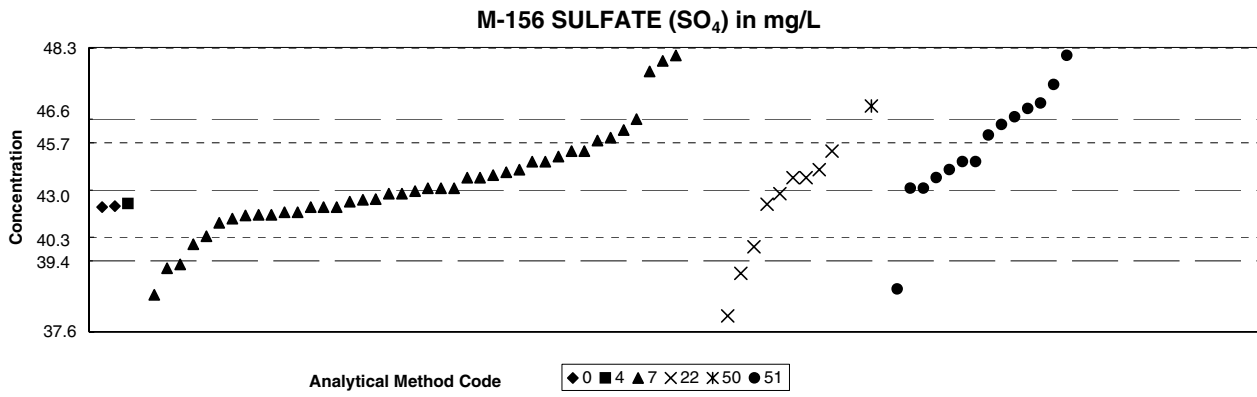

Summary	Methods						Statistics	
	0	4	7	22	50	51	Method Codes	
N =	2	1	43	11	3	18	0. Other	MPV = 43.0 mg/L
Minimum =	42.3	42.4	4.0	20.0	33.1	20.5	4. Inductively coupled plasma	F-pseudosigma = 1.78
Maximum =	42.3	56.8	44.4	46.1	100.0		7. Ion chromatography	Rating criterion = 2.15
Median =		42.9	42.4	45.2			22. Colorimetric	N = 78
F-pseudosigma =		1.52	3.26	2.59			50. Gravimetric	Uh = 44.4
							51. Turbidimetric	Lh = 42.0

Lab	Rating	Z-value	Methods					
			0	4	7	22	50	51
1	4	-0.33	--	--	42.3	--	--	--
10	2	1.12	--	--	--	--	--	45.4
12	4	-0.09	--	--	--	42.8	--	--
13	4	0.23	--	--	43.5	--	--	--
18	0	-2.23	--	--	--	38.2	--	--
23	0	2.05	--	--	47.4	--	--	--
24	2	-1.02	--	--	--	40.8	--	--
25	3	0.65	--	--	44.4	--	--	--
42	3	0.65	--	--	44.4	--	--	--
45	4	0.00	--	--	43.0	--	--	--
48	0	3.26	--	--	--	--	--	50.0
50	4	0.19	--	--	--	43.4	--	--
51	4	-0.33	--	--	42.3	--	--	--
55	2	1.49	--	--	--	--	--	46.2
57	0	-3.26	--	--	--	36.0	--	--
59	3	-0.53	--	--	41.9	--	--	--
64	4	0.47	--	--	44.0	--	--	--
69	4	-0.23	--	--	42.5	--	--	--
70	0	2.23	--	--	47.8	--	--	--
76	4	-0.20	--	--	42.6	--	--	--
81	2	-1.49	--	--	--	39.8	--	--
86	0	2.33	--	--	48.0	--	--	--
87	4	0.00	--	--	--	--	--	43.0
89	3	-0.84	--	--	41.2	--	--	--
93	3	0.88	--	--	44.9	--	--	--
96	3	0.93	--	--	--	--	--	45.0
97	4	-0.28	--	--	--	42.4	--	--
105	4	-0.42	--	--	42.1	--	--	--
107	2	1.02	--	--	45.2	--	--	--
109	0	-2.56	--	--	--	--	--	37.5
113	4	-0.33	42.3	--	--	--	--	--
114	2	1.44	--	--	--	--	--	46.1
127	4	-0.09	--	--	42.8	--	--	--
129	2	-1.40	--	--	40.0	--	--	--
131	4	0.33	--	--	43.7	--	--	--
134	4	-0.47	--	--	42.0	--	--	--
138	4	0.19	--	--	43.4	--	--	--
140	2	1.40	--	--	--	--	--	46.0
142	4	-0.05	--	--	42.9	--	--	--
154	4	0.33	--	--	--	--	--	43.7
180	0	-18.13	--	--	4.0	--	--	--
190	4	0.19	--	--	43.4	--	--	--
203	4	0.19	--	--	43.4	--	--	--
204	3	0.65	--	--	44.4	--	--	--
208	4	-0.47	--	--	42.0	--	--	--
212	4	-0.33	--	--	42.3	--	--	--
215	0	26.51	--	--	--	--	--	100.0
220	1	-1.76	--	--	--	--	--	39.2
230	4	-0.27	--	42.4	--	--	--	--
234	3	-0.98	--	--	40.9	--	--	--

Lab	Rating	Z-value	Methods					
			0	4	7	22	50	51
247	3	0.84	--	--	44.8	--	--	--
254	4	-0.09	--	--	42.8	--	--	--
255	4	0.33	--	--	--	43.7	--	--
256	4	-0.31	42.3	--	--	--	--	--
257	2	1.21	--	--	--	45.6	--	--
258	4	0.19	--	--	--	--	--	43.4
259	4	0.00	--	--	43.0	--	--	--
261	0	-10.70	--	--	--	20.0	--	--
263	4	0.47	--	--	--	--	--	44.0
265	4	-0.47	--	--	42.0	--	--	--
266	4	0.47	--	--	--	--	--	44.0
268	4	-0.19	--	--	42.6	--	--	--
270	0	6.40	--	--	56.8	--	--	--
273	4	0.47	--	--	44.0	--	--	--
274	2	1.25	--	--	--	--	--	45.7
275	4	0.00	--	--	--	--	--	43.0
276	0	-10.47	--	--	--	--	--	20.5
277	4	-0.42	--	--	42.1	--	--	--
287	2	-1.33	--	--	40.1	--	--	--
304	4	0.00	--	--	43.0	--	--	--
307	0	3.72	--	--	--	--	--	51.0
309	0	2.33	--	--	--	--	--	48.0
315	4	0.28	--	--	43.6	--	--	--
323	3	-0.60	--	--	41.7	--	--	--
324	0	-4.60	--	--	--	--	--	33.1
328	1	-1.86	--	--	39.0	--	--	--
331	3	0.56	--	--	44.2	--	--	--
334	1	1.81	--	--	--	--	--	46.9

Table 12. Statistical summary of reported data for standard reference samples M-156 (major constituents) -- Continued

M-156 SPECIFIC CONDUCTANCE (Sp Cond) in $\mu\text{S}/\text{cm}$

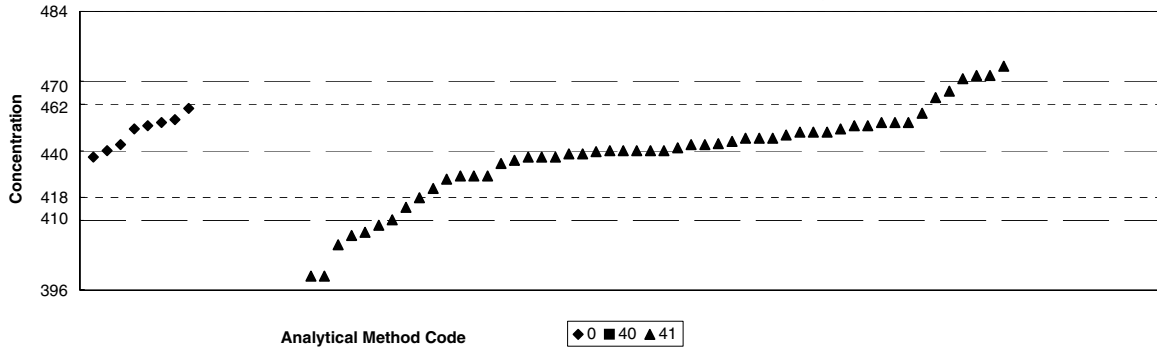

Summary	Methods			Statistics
	0	40	41	
N =	8	1	61	MPV = 440 $\mu\text{S}/\text{cm}$
Minimum =	438	75.0	26.6	F-pseudostandard deviation = 14.8
Maximum =	454		2480	Rating criterion = 22.0
Median =	448		440	N = 70
F-pseudostandard deviation =	6.30		15.6	Uh = 448
				Lh = 428

Lab	Rating	Z-value	Methods		
			0	40	41
1	4	0.10	--	--	442
10	4	0.00	--	--	440
12	4	0.27	--	--	446
13	4	-0.09	--	--	438
23	4	-0.36	--	--	432
24	4	0.00	--	--	440
25	2	1.09	--	--	464
42	4	0.41	--	--	449
45	4	0.14	--	--	443
48	4	0.41	--	--	449
50	4	0.09	--	--	442
51	4	-0.36	--	--	432
57	0	-2.27	--	--	390
59	4	-0.05	--	--	439
64	3	0.86	--	--	459
70	3	0.55	--	--	452
81	3	-0.68	--	--	425
86	4	0.27	--	--	446
87	1	-1.82	--	--	400
89	0	-18.79	--	--	27
93	2	-1.08	--	--	416
96	4	0.32	--	--	447
97	4	0.27	--	--	446
105	4	0.18	--	--	444
109	4	-0.05	--	--	439
113	4	-0.09	438	--	--
114	3	-0.55	--	--	428
118	1	-1.82	--	--	400
127	0	-8.95	--	--	243
129	2	-1.23	--	--	413
134	4	-0.01	--	--	440
138	4	0.41	--	--	449
140	2	-1.36	--	--	410
142	4	0.00	--	--	440
154	0	-2.29	--	--	390
155	3	-0.82	--	--	422
180	0	92.73	--	--	2480
190	4	0.36	--	--	448
193	4	-0.18	--	--	436
203	4	0.09	--	--	442
212	4	-0.41	--	--	431
215	4	-0.09	--	--	438
230	0	-2.27	--	--	390
234	4	-0.09	--	--	438
243	4	0.41	449	--	--
247	4	0.23	--	--	445
256	4	0.32	447	--	--
257	2	1.23	--	--	467
258	4	0.00	--	--	440
259	4	0.18	--	--	444

Lab	Rating	Z-value	Methods		
			0	40	41
261	0	-3.27	--	--	368
263	4	0.36	--	--	448
267	4	0.18	--	--	444
268	3	0.77	--	--	457
273	4	0.36	448	--	--
274	4	-0.14	--	--	437
275	4	0.45	450	--	--
276	4	0.00	--	--	440
277	4	-0.36	--	--	432
279	3	-1.00	--	--	418
280	4	0.09	442	--	--
287	2	-1.18	--	--	414
297	2	1.05	--	--	463
306	3	0.61	454	--	--
307	2	1.09	--	--	464
323	0	-16.59	--	75	--
324	0	23.82	--	--	964
328	4	0.00	440	--	--
331	0	-5.14	--	--	327
333	4	0.05	--	--	441

Table 12. Statistical summary of reported data for standard reference samples M-156 (major constituents) -- Continued

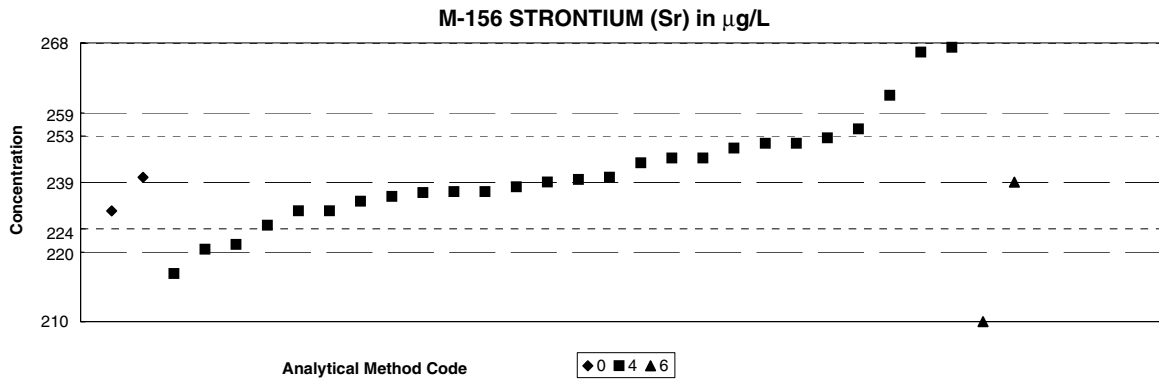

Summary	Methods			Method Codes	Statistics	
	0	4	6			
N =	2	26	2	0. Other	MPV =	239 µg/L
Minimum =	233	220	210	4. Inductively coupled plasma	F-pseudostigma =	9.64
Maximum =	240	267	239	6. Inductively coupled plasma/mass spectrometry	Rating criterion =	12.0
Median =		239			N =	30
F-pseudostigma =		8.90			Uh =	246
					Lh =	233

Lab	Rating	Z-value	Methods		
			0	4	6
1	4	0.00	--	--	239
24	3	0.67	--	247	--
25	1	-1.59	--	220	--
42	3	0.92	--	250	--
57	4	-0.50	--	233	--
81	4	0.42	--	244	--
86	4	0.42	--	244	--
105	2	-1.17	--	225	--
113	4	-0.50	233	--	--
121	4	0.08	--	240	--
127	4	-0.08	--	238	--
134	4	-0.18	--	237	--
138	2	-1.09	--	226	--
142	3	0.59	--	246	--
154	4	0.00	--	239	--
212	4	-0.50	--	233	--
234	4	-0.25	--	236	--
235	4	-0.33	--	235	--
247	4	-0.17	--	237	--
254	2	1.51	--	257	--
256	4	0.08	240	--	--
259	4	0.04	--	240	--
265	3	-0.75	--	230	--
270	3	0.77	--	248	--
273	0	2.26	--	266	--
309	3	0.67	--	247	--
323	4	-0.17	--	237	--
328	0	-2.43	--	--	210
331	0	2.34	--	267	--
333	4	0.33	--	243	--

Table 12. Statistical summary of reported data for standard reference samples M-156 (major constituents) -- Continued

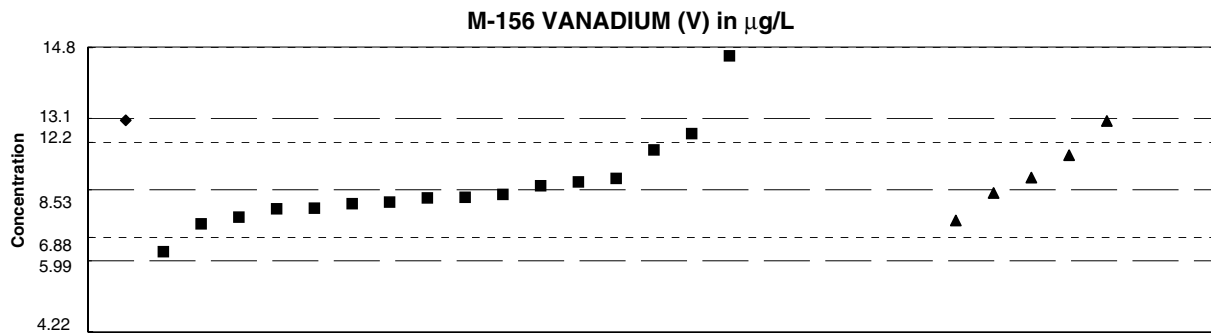

Analytical Method Code ◆ 3 ■ 4 ▲ 6

Summary	Methods			Statistics
	3	4	6	
N =	1	18	5	MPV = 9.53 µg/L F-pseudsigma = 1.77 N = 24 Uh = 11.30 Lh = 8.92
Minimum =	12.10	7.21	8.37	
Maximum =	29.00	12.08		
Median =	9.29	9.97		
F-pseudsigma =	1.61	1.04		
	Method Codes			
	3. Atomic absorption: graphite furnace			
	4. Inductively coupled plasma			
	6. Inductively coupled plasma/mass spectrometry			

Lab	Rating	Z-value	Methods		
			3	4	6
1	2	1.44	--	--	12.08
13	NR	--	--	<50	--
25	NR	--	--	<0.01	--
42	3	0.72	--	--	10.80
48	4	-0.07	--	--	9.40
57	4	-0.40	--	8.83	--
81	4	-0.30	--	9.00	--
86	2	1.17	--	11.60	--
89	2	1.45	12.10	--	--
105	NR	--	--	<20.0	--
127	3	-0.73	--	8.24	--
134	4	-0.27	--	9.06	--
138	4	-0.11	--	9.34	--
142	3	-0.66	--	--	8.37
154	4	0.15	--	9.80	--
180	0	7.34	--	22.50	--
212	4	-0.41	--	8.80	--
215	0	11.01	--	29.00	--
234	4	0.07	--	9.66	--
235	2	-1.31	--	7.21	--
247	4	0.25	--	--	9.97
265	3	-0.58	--	8.50	--
297	4	0.23	--	9.94	--
305	4	-0.18	--	9.21	--
323	4	-0.17	--	9.23	--
328	0	2.81	--	14.50	--
331	3	0.83	--	11.00	--

Table 13. Statistical summary of reported data for standard reference samples N-67 (nutrient constituents)

N-67 AMMONIA as NITROGEN (NH₃ as N) in mg/L

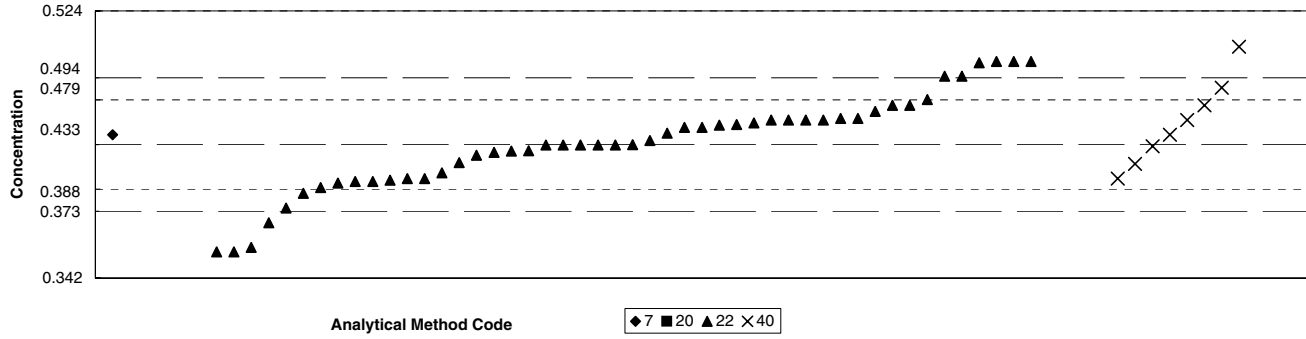

Summary	Methods				Method Codes	Statistics
	7	20	22	40		
N =	1	0	54	8	7. Ion chromatography	MPV = 0.433 mg/L
Minimum =	0.440	<1.00	0.040	0.410	20. Titration: colorimetric	F-pseudosigma = 0.030
Maximum =			5.310	0.500	22. Colorimetric	N = 63
Median =			0.433	0.445	40. Ion selective electrode	Uh = 0.451
F-pseudosigma =		0.032	0.030			Lh = 0.410

Lab	Rating	Z-value	Methods			
			7	20	22	40
1	4	-0.01	--	--	0.433	--
5	3	-0.80	--	--	0.409	--
12	0	4.89	--	--	0.582	--
13	1	1.54	--	--	0.480	--
18	0	-4.75	--	--	0.289	--
21	4	-0.01	--	--	0.433	--
23	3	0.55	--	--	0.450	--
25	2	-1.42	--	--	0.390	--
31	4	-0.01	--	--	0.433	--
38	4	0.45	--	--	0.447	--
46	3	0.75	--	--	0.456	--
48	0	-2.41	--	--	0.360	--
51	3	0.55	--	--	0.450	--
59	4	-0.14	--	--	0.429	--
64	1	1.87	--	--	0.490	--
70	0	-12.32	--	--	0.059	--
72	0	-2.41	--	--	0.360	--
81	4	-0.40	--	--	0.421	--
83	3	-0.87	--	--	0.407	--
86	0	-2.31	--	--	0.363	--
87	3	-0.77	--	--	0.410	--
88	0	-10.90	--	--	0.102	--
89	4	-0.01	--	--	0.433	--
90	3	-0.77	--	--	0.410	--
93	3	0.88	--	--	0.460	--
96	4	-0.01	--	--	0.433	--
97	1	1.83	--	--	0.489	--
105	3	0.88	--	--	0.460	--
110	4	0.44	--	--	0.447	--
113	3	0.55	--	--	0.450	--
114	4	0.22	--	--	0.440	--
118	0	-12.94	--	--	0.040	--
127	4	0.38	--	--	0.445	--
129	3	-0.83	--	--	0.408	--
134	4	0.25	--	--	0.441	--
138	3	0.58	--	--	0.451	--
140	0	5.16	--	--	0.590	--
142	3	0.58	--	--	0.451	--
151	3	-0.77	--	--	0.410	--
154	3	0.55	--	--	0.450	--
155	4	0.00	--	--	0.433	--
180	3	-0.96	--	--	0.404	--
190	4	0.09	--	--	0.436	--
193	2	-1.10	--	--	0.400	--
203	3	0.55	--	--	0.450	--
212	4	-0.24	--	--	0.426	--
213	NR	--	--	<1.0	--	--
215	1	1.87	--	--	0.490	--
224	1	1.54	--	--	0.480	--
234	4	-0.04	--	--	0.432	--

Lab	Rating	Z-value	Methods			
			7	20	22	40
243	4	-0.17	--	--	0.428	--
247	1	-1.75	--	--	0.380	--
287	0	2.19	--	--	0.500	--
297	2	1.01	--	--	0.464	--
305	3	0.88	--	--	0.460	--
306	2	1.27	--	--	0.472	--
307	4	-0.44	--	--	0.420	--
313	3	-0.83	--	--	0.408	--
316	4	-0.14	--	--	0.429	--
318	4	0.38	--	--	0.445	--
320	3	-0.64	--	--	0.414	--
321	0	160.46	--	--	5.310	--
323	4	0.48	--	--	0.448	--
328	NR	--	--	--	<.05	--
333	4	0.22	0.440	--	--	--

Table 13. Statistical summary of reported data for standard reference samples N-67 (nutrient constituents) -- Continued

N-67 AMMONIA + ORGANIC NITROGEN as NITROGEN (NH₃ + Organic N as N) in mg/L

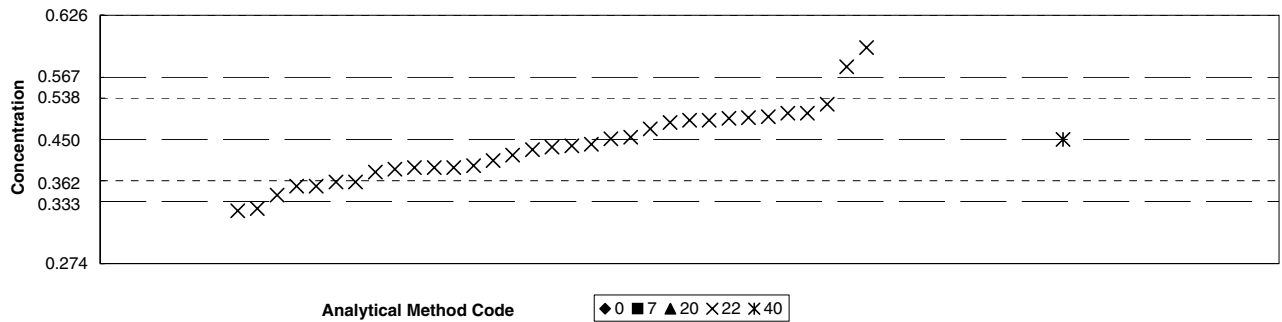

Summary	Methods					Method Codes	Statistics	
	0	7	20	22	40			
N =	1	1	0	41	2	0. Other	MPV =	0.450 mg/L
Minimum =	0.032	0.780	<1.00	0.060	0.450	7. Ion chromatography	F-pseudosigma =	0.059
Maximum =				1.187	0.648	20. Titration: colorimetric	N =	45
Median =				0.443		22. Colorimetric	Uh =	0.487
F-pseudosigma =				0.059		40. Ion selective electrode	Lh =	0.408

Lab	Rating	Z-value	Methods				
			0	7	20	22	40
1	4	0.02	--	--	--	0.451	--
5	0	4.95	--	--	--	0.740	--
12	0	5.29	--	--	--	0.760	--
18	0	2.22	--	--	--	0.580	--
21	3	0.63	--	--	--	0.487	--
23	1	-1.72	--	--	--	0.349	--
25	0	5.64	--	0.780	--	--	--
31	3	0.63	--	--	--	0.487	--
38	2	-1.02	--	--	--	0.390	--
46	3	0.55	--	--	--	0.482	--
48	3	0.85	--	--	--	0.500	--
51	4	0.00	--	--	--	--	0.450
59	4	-0.12	--	--	--	0.443	--
70	3	-0.79	--	--	--	0.404	--
72	2	-1.13	--	--	--	0.384	--
81	3	-0.51	--	--	--	0.420	--
87	3	-0.68	--	--	--	0.410	--
89	4	0.46	--	--	--	0.477	--
90	3	-0.72	--	--	--	0.408	--
96	3	-0.63	--	--	--	0.413	--
97	2	-1.02	--	--	--	0.390	--
105	NR	--	--	--	--	<1.00	--
113	NR	--	--	--	--	<0.5	--
118	0	-6.66	--	--	--	0.060	--
127	4	0.05	--	--	--	0.453	--
129	0	12.58	--	--	--	1.187	--
134	4	0.41	--	--	--	0.474	--
138	3	0.53	--	--	--	0.481	--
140	0	3.93	--	--	--	0.680	--
142	2	-1.13	--	--	--	0.384	--
154	3	0.51	--	--	--	0.480	--
155	4	-0.25	--	--	--	0.435	--
180	4	-0.15	--	--	--	0.441	--
193	3	-0.68	--	--	--	0.410	--
203	0	-3.24	--	--	--	0.260	--
212	4	0.46	--	--	--	0.477	--
213	NR	--	--	--	<1.0	--	--
215	0	4.27	--	--	--	0.700	--
224	1	1.76	--	--	--	0.553	--
247	1	-1.67	--	--	--	0.352	--
297	4	-0.38	--	--	--	0.428	--
305	NR	--	--	--	<1.0	--	--
306	0	3.38	--	--	--	--	0.648
313	2	-1.35	--	--	--	0.371	--
316	4	-0.19	--	--	--	0.439	--
318	4	0.26	--	--	--	0.465	--
320	0	3.67	--	--	--	0.665	--
323	3	-0.68	--	--	--	0.410	--
328	0	-7.14	0.032	--	--	--	--

Table 13. Statistical summary of reported data for standard reference samples N-67 (nutrient constituents) -- Continued

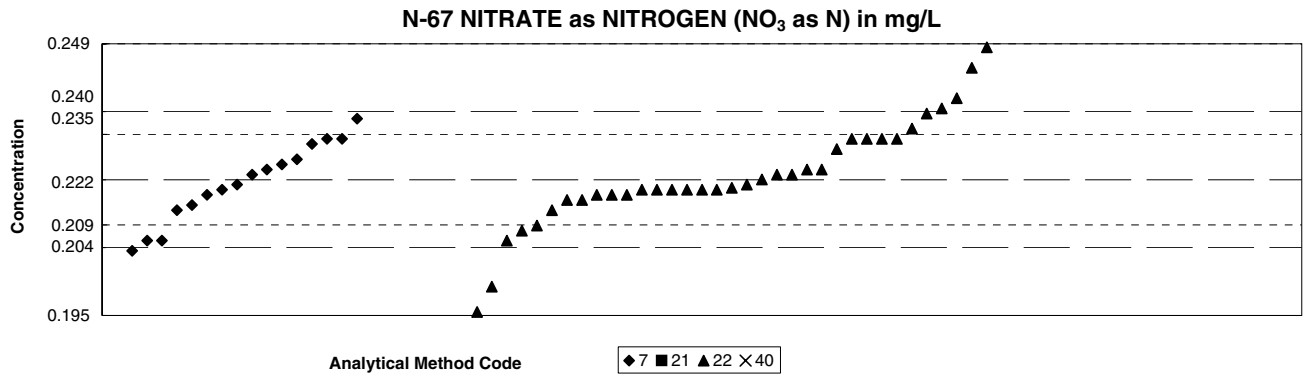

Summary	Methods				Statistics
	7	21	22	40	
N =	19	1	44	1	MPV = 0.222 mg/L
Minimum =	0.190	0.450	0.030	0.270	F-pseudsigma = 0.009
Maximum =	0.640		1.700		Rating criterion= 0.011
Median =	0.223		0.221		N = 65
F-pseudsigma =	0.010		0.010		Uh = 0.230
					Lh = 0.218

Lab	Rating	Z-value	Methods			
			7	21	22	40
1	2	-1.08	--	--	0.210	--
5	4	-0.27	--	--	0.219	--
12	4	-0.18	--	--	0.220	--
13	4	-0.09	0.221	--	--	--
18	0	-2.34	--	--	0.196	--
21	4	-0.36	--	--	0.218	--
23	4	-0.45	0.217	--	--	--
25	4	0.36	0.226	--	--	--
31	4	-0.36	--	--	0.218	--
38	4	0.00	--	--	0.222	--
42	4	-0.27	0.219	--	--	--
45	3	0.72	0.230	--	--	--
46	1	-1.89	--	--	0.201	--
48	0	20.54	--	0.450	--	--
51	0	3.42	0.260	--	--	--
59	4	-0.18	--	--	0.220	--
64	4	-0.18	--	--	0.220	--
69	4	-0.18	0.220	--	--	--
70	4	-0.27	--	--	0.219	--
72	0	13.33	--	--	0.370	--
81	2	1.44	--	--	0.238	--
83	4	-0.18	--	--	0.220	--
86	0	-2.79	--	--	0.191	--
87	0	2.52	--	--	0.250	--
88	0	-10.54	--	--	0.105	--
89	4	0.09	--	--	0.223	--
90	4	-0.18	--	--	0.220	--
93	4	0.09	0.223	--	--	--
96	4	0.18	--	--	0.224	--
97	3	0.72	--	--	0.230	--
105	3	0.72	--	--	0.230	--
113	4	0.18	--	--	0.224	--
118	0	-17.30	--	--	0.030	--
127	0	2.97	--	--	0.255	--
129	4	0.18	0.224	--	--	--
134	3	0.72	--	--	0.230	--
138	4	-0.09	--	--	0.221	--
140	4	0.09	--	--	0.223	--
142	0	2.70	--	--	0.252	--
154	4	-0.18	--	--	0.220	--
155	0	-4.31	--	--	0.174	--
180	4	0.27	0.225	--	--	--
190	4	-0.27	--	--	0.219	--
193	3	0.72	0.230	--	--	--
203	2	-1.08	0.210	--	--	--
209	2	-1.26	0.208	--	--	--
212	2	1.26	--	--	0.236	--
215	0	133.15	--	--	1.700	--
220	0	2.34	--	--	0.248	--
224	3	0.63	0.229	--	--	--

Lab	Rating	Z-value	Methods			
			7	21	22	40
234	3	-0.54	0.216	--	--	--
243	3	0.72	--	--	0.230	--
247	0	-2.88	0.190	--	--	--
287	0	37.66	0.640	--	--	--
297	1	1.98	--	--	0.244	--
305	0	4.32	--	--	--	0.270
306	3	-0.54	--	--	0.216	--
307	3	0.90	--	--	0.232	--
313	3	-0.81	--	--	0.213	--
316	4	-0.14	--	--	0.220	--
318	2	1.17	--	--	0.235	--
320	3	-0.90	--	--	0.212	--
321	2	-1.08	0.210	--	--	--
323	3	0.54	--	--	0.228	--
328	NR	--	--	--	<.05	--
333	2	1.08	0.234	--	--	--

Table 13. Statistical summary of reported data for standard reference samples N-67 (nutrient constituents) -- Continued

N-67 TOTAL PHOSPHORUS as PHOSPHORUS (Total P as P) in mg/L

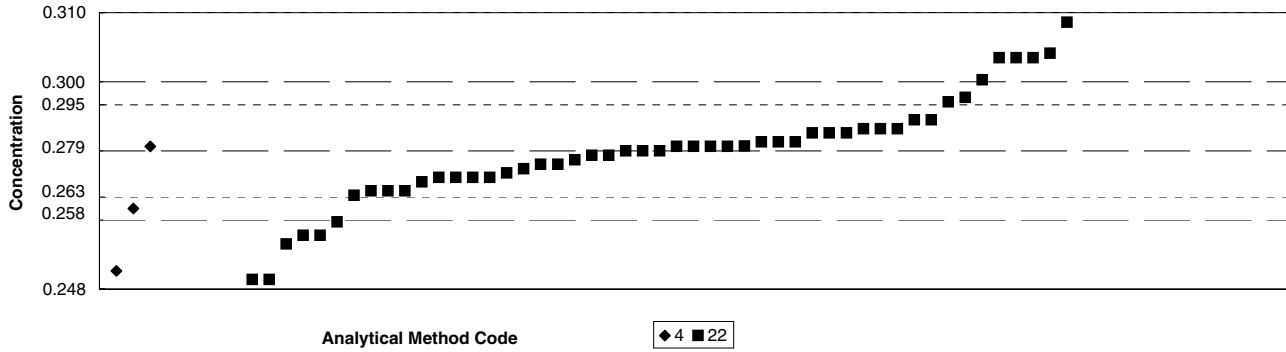

Summary	Methods		Method Codes	Statistics
	4	22		
N =	3	58	4. Inductively coupled plasma 22. Colorimetric	MPV = 0.279 mg/L F-pseudostigma = 0.010 Rating criterion = 0.014 N = 61 Uh = 0.284 Lh = 0.270
Minimum =	0.252	0.030		
Maximum =	0.280	0.870		
Median =		0.279		
F-pseudostigma =		0.010		

Lab	Rating	Z-value	Methods	
			4	22
1	4	0.00	--	0.279
5	2	-1.36	--	0.260
12	4	-0.43	--	0.273
13	4	0.07	--	0.280
18	4	-0.43	--	0.273
21	4	-0.22	--	0.276
23	0	-3.08	--	0.236
25	0	-2.08	--	0.250
31	4	-0.22	--	0.276
38	2	-1.15	--	0.263
42	1	-1.94	0.252	--
45	0	-2.08	--	0.250
46	4	-0.36	--	0.274
48	2	1.51	--	0.300
51	4	-0.50	--	0.272
59	3	-0.72	--	0.269
70	0	-5.38	--	0.204
72	0	-7.46	--	0.175
81	3	0.79	--	0.290
83	4	0.07	0.280	--
86	3	-0.93	0.266	--
87	4	-0.14	--	0.277
89	3	-0.65	--	0.270
93	0	3.30	--	0.325
96	4	0.07	--	0.280
97	2	1.51	--	0.300
105	3	-0.65	--	0.270
113	4	-0.07	--	0.278
114	2	-1.36	--	0.260
118	0	-17.85	--	0.030
127	3	0.86	--	0.291
129	4	0.36	--	0.284
134	4	0.29	--	0.283
138	4	0.14	--	0.281
140	4	0.07	--	0.280
142	4	0.00	--	0.279
154	2	1.15	--	0.295
155	4	0.08	--	0.280
180	4	-0.43	--	0.273
183	4	-0.29	--	0.275
190	4	-0.43	--	0.273
193	2	-1.51	--	0.258
203	4	0.36	--	0.284
212	0	-3.87	--	0.225
213	3	-0.65	--	0.270
215	0	42.37	--	0.870
224	2	1.51	--	0.300
234	4	0.36	--	0.284
243	4	0.07	--	0.280
247	4	0.50	--	0.286

Lab	Rating	Z-value	Methods	
			4	22
297	4	0.14	--	0.281
305	4	-0.07	--	0.278
306	0	2.08	--	0.308
307	4	0.29	--	0.283
313	4	0.50	--	0.286
316	0	2.85	--	0.319
318	4	0.14	--	0.281
320	4	0.29	--	0.283
321	1	1.58	--	0.301
323	4	0.00	--	0.279
328	0	3.66	--	0.330

Table 13. Statistical summary of reported data for standard reference samples N-67 (nutrient constituents) -- Continued

N-67 ORTHOPHOSPHATE as PHOSPHORUS (PO₄ as P) in mg/L

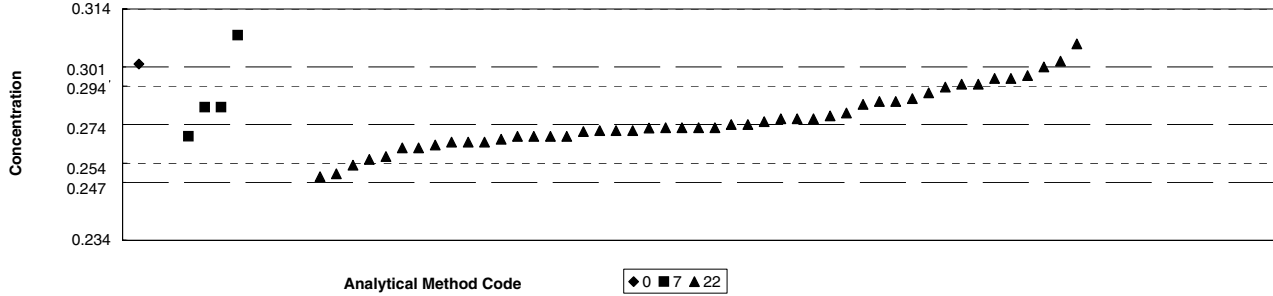

Summary	Methods			Method Codes	Statistics	
	0	7	22			
N =	2	6	53	0. Other	MPV =	0.274 mg/L
Minimum =	0.295	0.224	0.030	7. Ion chromatography	F-pseudosigma =	0.013
Maximum =	1.010	2.990	0.810	22. Colorimetric	Rating criterion =	0.014
Median =		0.280	0.273		N =	61
F-pseudosigma =		0.026	0.011		Uh =	0.287
					Lh =	0.269

Lab	Rating	Z-value	Methods		
			0	7	22
1	4	0.00	--	--	0.274
5	0	-3.21	--	--	0.230
12	4	0.15	--	--	0.276
13	0	-3.65	--	0.224	--
18	4	0.15	--	--	0.276
21	4	-0.07	--	--	0.273
23	3	-0.80	--	--	0.263
25	3	-0.51	--	--	0.267
31	4	-0.07	--	--	0.273
38	3	-0.88	--	--	0.262
42	0	2.26	--	0.305	--
45	4	0.44	--	0.280	--
46	0	2.04	--	--	0.302
48	2	1.17	--	--	0.290
51	4	-0.29	--	--	0.270
59	3	-0.58	--	--	0.266
64	4	0.29	--	--	0.278
70	4	-0.44	--	--	0.268
72	0	4.38	--	--	0.334
81	2	1.02	--	--	0.288
83	4	0.00	--	--	0.274
87	4	-0.44	--	--	0.268
88	0	4.74	--	--	0.339
89	4	-0.29	--	--	0.270
93	0	-3.21	--	--	0.230
96	4	-0.44	--	--	0.268
97	4	0.07	--	--	0.275
105	2	1.17	--	--	0.290
113	4	-0.29	--	--	0.270
118	0	-17.81	--	--	0.030
127	3	0.95	--	--	0.287
129	3	0.58	--	--	0.282
134	3	0.66	--	--	0.283
138	4	-0.15	--	--	0.272
140	4	-0.29	--	--	0.270
142	4	-0.07	--	--	0.273
154	1	1.53	0.295	--	--
155	4	-0.18	--	--	0.272
180	3	0.58	--	--	0.282
183	3	-0.58	--	--	0.266
190	4	-0.07	--	--	0.273
203	2	-1.24	--	--	0.257
212	4	-0.36	--	--	0.269
213	2	-1.02	--	--	0.260
215	0	39.12	--	--	0.810
220	3	0.80	--	--	0.285
224	2	1.24	--	--	0.291
234	4	0.44	--	0.280	--
247	4	-0.29	--	0.270	--
287	0	198.25	--	2.990	--

Lab	Rating	Z-value	Methods		
			0	7	22
297	4	-0.15	--	--	0.272
305	3	0.51	--	--	0.281
306	4	0.15	--	--	0.276
307	1	1.61	--	--	0.296
313	2	1.02	--	--	0.288
316	4	-0.09	--	--	0.273
318	2	1.46	--	--	0.294
320	2	-1.31	--	--	0.256
321	4	-0.15	--	--	0.272
323	4	0.22	--	--	0.277
328	0	53.72	1.010	--	--

Table 14. Statistical summary of reported data for standard reference samples N-68 (nutrient constituents)

N-68 AMMONIA as NITROGEN (NH₃ as N) in mg/L

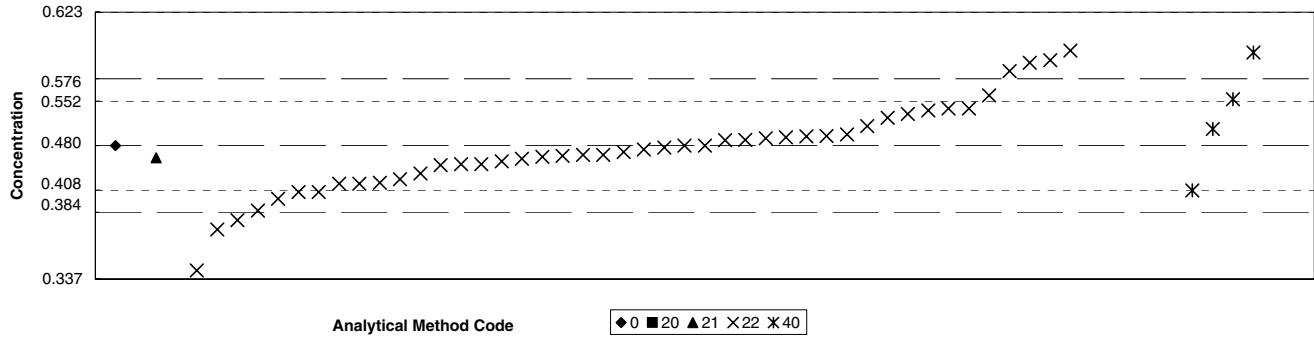

Summary	Methods					Method Codes	Statistics
	0	20	21	22	40		
N =	1	0	1	50	4	0. Other	MPV = 0.480 mg/L
Minimum =	0.480	0.000	0.467	0.040	0.432	20. Titration: colorimetric	F-pseudostigma = 0.048
Maximum =				4.730	0.580	21. Titration: electrometric	N = 56
Median =				0.479		22. Colorimetric	Uh = 0.519
F-pseudostigma =				0.050		40. Ion selective electrode	Lh = 0.455

Lab	Rating	Z-value	Methods				
			0	20	21	22	40
1	4	-0.29	--	--	--	0.466	--
5	0	20.22	--	--	--	1.447	--
12	2	-1.19	--	--	--	0.423	--
13	3	0.84	--	--	--	0.520	--
18	0	-2.80	--	--	--	0.346	--
23	3	-0.84	--	--	--	0.440	--
25	2	-1.46	--	--	--	0.410	--
38	0	3.95	--	--	--	0.669	--
46	2	1.13	--	--	--	0.534	--
48	2	-1.05	--	--	--	0.430	--
59	4	-0.23	--	--	--	0.469	--
64	4	-0.42	--	--	--	0.460	--
70	0	88.89	--	--	--	4.730	--
72	1	-1.67	--	--	--	0.400	--
81	4	-0.44	--	--	--	0.459	--
83	3	-0.86	--	--	--	0.439	--
84	2	1.05	--	--	--	--	0.530
86	3	-0.75	--	--	--	0.444	--
87	1	1.67	--	--	--	0.560	--
88	0	-9.20	--	--	--	0.040	--
89	4	-0.27	--	--	0.467	--	--
90	3	-0.86	--	--	--	0.439	--
93	3	0.84	--	--	--	0.520	--
96	4	-0.15	--	--	--	0.473	--
97	4	0.19	--	--	--	0.489	--
105	4	-0.21	--	--	--	0.470	--
107	0	3.70	--	--	--	0.657	--
113	4	0.17	--	--	--	0.488	--
118	4	-0.21	--	--	--	0.470	--
127	4	-0.25	--	--	--	0.468	--
129	4	0.00	--	--	--	0.480	--
134	0	2.13	--	--	--	0.582	--
138	4	0.25	--	--	--	0.492	--
140	0	3.56	--	--	--	0.650	--
142	1	1.92	--	--	--	0.572	--
154	4	-0.42	--	--	--	0.460	--
155	4	0.22	--	--	--	0.490	--
180	4	-0.36	--	--	--	0.463	--
190	4	0.13	--	--	--	0.486	--
193	1	-1.88	--	--	--	0.390	--
203	4	0.21	--	--	--	0.490	--
204	4	0.00	--	--	--	0.480	--
212	1	1.86	--	--	--	0.569	--
213	NR	--	--	<1.0	--	--	--
215	2	-1.05	--	--	--	0.430	--
224	3	0.63	--	--	--	0.510	--
234	3	-1.00	--	--	--	--	0.432
243	4	-0.04	--	--	--	0.478	--
247	4	0.44	--	--	--	0.501	--
287	0	2.09	--	--	--	--	0.580

Lab	Rating	Z-value	0	20	21	22	40
297	3	0.71	--	--	--	0.514	--
306	4	0.38	--	--	--	--	0.498
313	4	-0.08	--	--	--	0.476	--
314	4	0.00	0.480	--	--	--	--
316	4	0.13	--	--	--	0.486	--
320	3	0.79	--	--	--	0.518	--
328	3	-0.63	--	--	--	0.450	--

**Table 14. Statistical summary of reported data for standard reference samples N-68 (nutrient constituents)--
Continued**

N-68 AMMONIA + ORGANIC NITROGEN as NITROGEN (NH₃ + Organic N as N) in mg/L

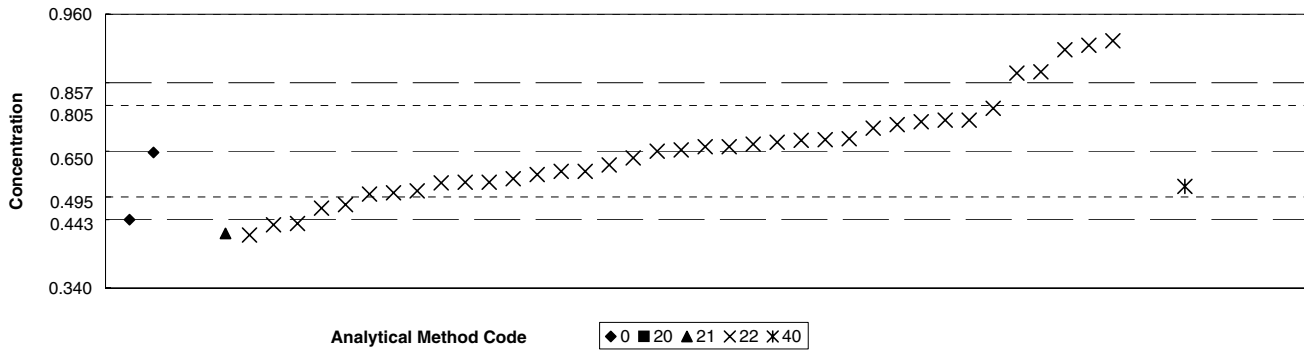

Summary	Methods					Method Codes	Statistics	
	0	20	21	22	40			
N =	2	1	1	38	1	0. Other	MPV =	0.650 mg/L
Minimum =	0.495	1.200	0.464	0.460	0.570	20. Titration: colorimetric	F-pseudostigma =	0.103
Maximum =	0.647			2.436		21. Titration: electrometric	N =	43
Median =				0.657		22. Colorimetric	Uh =	0.714
F-pseudostigma =				0.102		40. Ion selective electrode	Lh =	0.574

Lab	Rating	Z-value	Methods				
			0	20	21	22	40
1	4	-0.15	--	--	--	0.635	--
5	4	0.19	--	--	--	0.670	--
12	3	0.68	--	--	--	0.720	--
18	1	1.74	--	--	--	0.830	--
23	4	0.10	--	--	--	0.660	--
25	0	2.42	--	--	--	0.900	--
38	3	-0.68	--	--	--	0.580	--
46	4	-0.30	--	--	--	0.619	--
48	3	-0.68	--	--	--	0.580	--
59	4	0.24	--	--	--	0.675	--
70	3	-0.91	--	--	--	0.556	--
72	3	-0.51	--	--	--	0.597	--
81	1	-1.80	--	--	0.464	--	--
87	3	0.58	--	--	--	0.710	--
89	3	0.65	--	--	--	0.717	--
90	1	-1.59	--	--	--	0.486	--
96	4	-0.44	--	--	--	0.604	--
97	3	-0.87	--	--	--	0.560	--
105	NR	--	--	--	--	<1.00	--
118	4	0.10	--	--	--	0.660	--
127	3	0.94	--	--	--	0.747	--
129	1	1.71	--	--	--	0.827	--
134	4	0.15	--	--	--	0.666	--
138	4	0.03	--	--	--	0.653	--
140	0	2.32	--	--	--	0.890	--
142	4	0.27	--	--	--	0.678	--
154	4	0.00	--	--	--	0.650	--
155	4	-0.44	--	--	--	0.604	--
180	4	0.25	--	--	--	0.676	--
193	0	2.22	--	--	--	0.880	--
203	3	0.68	--	--	--	0.720	--
204	3	-0.70	--	--	--	0.578	--
212	3	-0.60	--	--	--	0.588	--
213	0	5.32	--	1.200	--	--	--
215	1	-1.84	--	--	--	0.460	--
224	3	-0.94	--	--	--	0.553	--
247	1	-1.61	--	--	--	0.483	--
297	2	-1.25	--	--	--	0.521	--
305	NR	--	--	<1.0	--	--	--
306	3	-0.77	--	--	--	0.570	--
313	4	0.50	--	--	--	0.702	--
314	4	-0.03	0.647	--	--	--	--
316	2	-1.17	--	--	--	0.529	--
320	0	17.27	--	--	--	2.436	--
328	2	-1.50	0.495	--	--	--	--

Table 14. Statistical summary of reported data for standard reference samples N-68 (nutrient constituents) -- Continued

N-68 NITRATE as NITROGEN (NO₃ as N) in mg/L

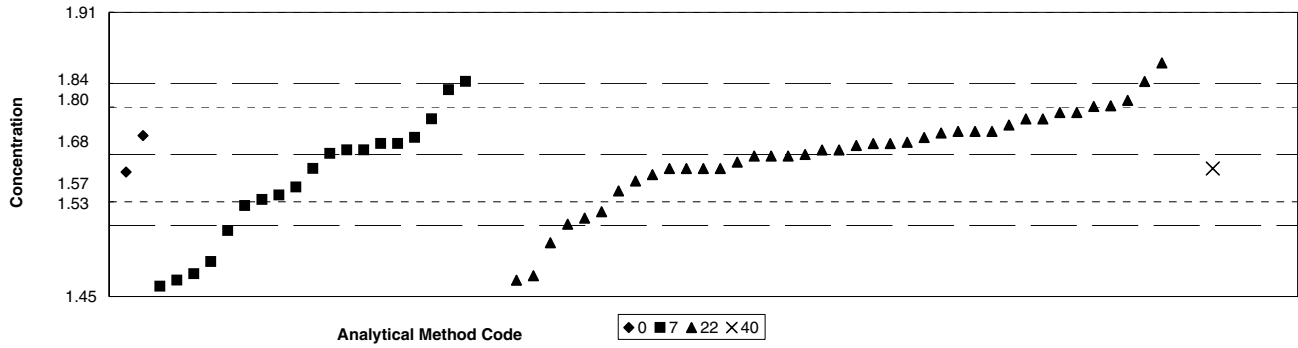

Summary	Methods				Statistics
	0	7	22	40	
N =	2	19	42	2	MPV = 1.68 mg/L
Minimum =	1.65	1.47	0.22	0.79	F-pseudostigma = 0.08
Maximum =	1.71	1.80	1.99	1.66	Rating criterion = 0.08
Median =		1.66	1.69		N = 65
F-pseudostigma =		0.09	0.06		Uh = 1.72
					Lh = 1.62

Lab	Rating	Z-value	Methods			
			0	7	22	40
1	3	-0.70	--	--	1.62	--
5	4	-0.15	--	--	1.67	--
12	4	0.44	--	--	1.72	--
13	3	-0.86	--	1.61	--	--
18	4	-0.03	--	--	1.68	--
23	3	0.80	--	--	1.75	--
25	3	-0.98	--	1.60	--	--
26	0	-2.53	--	1.47	--	--
38	4	0.23	--	--	1.70	--
42	4	0.02	--	1.68	--	--
45	4	0.21	--	1.70	--	--
46	4	-0.27	--	--	1.66	--
48	2	1.40	--	--	1.80	--
59	4	0.33	--	--	1.71	--
64	4	0.09	--	--	1.69	--
69	4	0.21	--	1.70	--	--
70	2	-1.22	--	--	1.58	--
72	1	1.75	--	--	1.83	--
81	4	-0.27	--	--	1.66	--
83	4	-0.03	--	--	1.68	--
84	3	0.68	--	1.74	--	--
86	1	-1.69	--	--	1.54	--
87	4	-0.51	--	--	1.64	--
88	0	-16.87	--	--	0.26	--
89	3	0.80	--	--	1.75	--
90	4	0.17	--	--	1.70	--
93	0	-2.05	--	1.51	--	--
96	4	-0.27	--	--	1.66	--
97	3	0.92	--	--	1.76	--
105	4	-0.03	--	--	1.68	--
107	2	-1.34	--	--	1.57	--
113	4	-0.34	1.65	--	--	--
118	4	0.44	--	--	1.72	--
127	2	-1.46	--	1.56	--	--
129	3	-0.78	--	1.62	--	--
134	4	0.41	--	--	1.72	--
138	4	-0.27	--	--	1.66	--
140	3	0.93	--	--	1.76	--
142	2	-1.10	--	--	1.59	--
154	4	0.44	--	--	1.72	--
155	0	-2.32	--	--	1.49	--
180	4	0.33	--	1.71	--	--
190	0	3.65	--	--	1.99	--
193	4	-0.27	--	1.66	--	--
203	0	-2.41	--	1.48	--	--
204	3	0.56	--	--	1.73	--
208	4	0.09	--	1.69	--	--
209	4	0.09	--	1.69	--	--
212	4	-0.39	--	--	1.65	--
215	0	-17.38	--	--	0.22	--

Lab	Rating	Z-value	0	7	22	40
220	4	0.09	--	--	1.69	--
224	2	1.24	--	1.79	--	--
234	3	-0.63	--	1.63	--	--
243	3	0.68	--	--	1.74	--
247	0	-2.29	--	1.49	--	--
287	2	1.40	--	1.80	--	--
291	0	-10.61	--	--	--	0.79
297	2	1.04	--	--	1.77	--
305	4	-0.27	--	--	--	1.66
306	0	-2.41	--	--	1.48	--
313	4	0.21	--	--	1.70	--
314	4	0.36	1.71	--	--	--
316	4	0.00	--	--	1.68	--
320	4	0.21	--	--	1.70	--
328	3	0.68	--	--	1.74	--

Table 14. Statistical summary of reported data for standard reference samples N-68 (nutrient constituents)--Continued

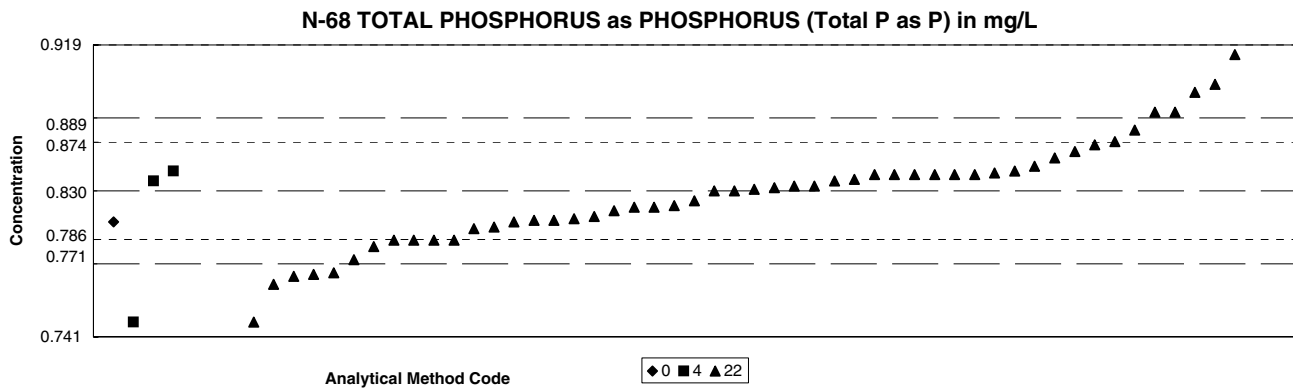

Summary	Methods			Method Codes	Statistics
	0	4	22		
N =	1	3	53	0. Other	MPV = 0.830 mg/L
Minimum =	0.811	0.750	0.290	4. Inductively coupled plasma	F-pseudostigma = 0.030
Maximum =		0.842	0.913	22. Colorimetric	Rating criterion= 0.042
Median =			0.830		N = 57
F-pseudostigma =			0.030		Uh = 0.840
					Lh = 0.800

Lab	Rating	Z-value	Methods		
			0	4	22
1	4	0.17	--	--	0.837
5	4	0.00	--	--	0.830
12	4	0.14	--	--	0.836
13	3	-0.72	--	--	0.800
18	4	-0.46	--	--	0.811
23	2	1.45	--	--	0.890
25	2	-1.20	--	--	0.780
38	2	-1.01	--	--	0.788
42	1	-1.93	--	0.750	--
45	4	0.24	--	--	0.840
46	4	-0.43	--	--	0.812
48	4	0.24	--	--	0.840
59	4	0.00	--	--	0.830
70	3	0.89	--	--	0.867
72	2	-1.37	--	--	0.773
81	4	-0.43	--	--	0.812
83	4	0.14	--	0.836	--
86	4	0.29	--	0.842	--
87	4	0.36	--	--	0.845
89	4	-0.24	--	--	0.820
93	3	0.58	--	--	0.854
96	3	-0.82	--	--	0.796
97	3	-0.72	--	--	0.800
105	1	-1.93	--	--	0.750
107	4	-0.22	--	--	0.821
113	3	-0.53	--	--	0.808
114	4	0.24	--	--	0.840
118	4	0.48	--	--	0.850
127	4	0.24	--	--	0.840
129	1	1.57	--	--	0.895
134	4	0.02	--	--	0.831
138	4	0.29	--	--	0.842
140	4	0.24	--	--	0.840
142	4	-0.14	--	--	0.824
154	2	1.16	--	--	0.878
155	4	-0.38	--	--	0.814
180	3	-0.55	--	--	0.807
183	4	0.07	--	--	0.833
190	4	-0.41	--	--	0.813
193	2	-1.23	--	--	0.779
203	3	0.72	--	--	0.860
204	4	0.07	--	--	0.833
212	0	-4.39	--	--	0.648
213	4	0.24	--	--	0.840
215	0	-13.01	--	--	0.290
224	4	-0.24	--	--	0.820
234	4	0.27	--	--	0.841
243	3	-0.72	--	--	0.800
247	4	-0.29	--	--	0.818
297	2	1.16	--	--	0.878

Lab	Rating	Z-value	0	4	22
305	4	0.05	--	--	0.832
306	0	-2.31	--	--	0.734
313	3	0.67	--	--	0.858
314	4	-0.46	0.811	--	--
316	0	2.00	--	--	0.913
320	2	-1.25	--	--	0.778
328	3	-0.72	--	--	0.800

Table 14. Statistical summary of reported data for standard reference samples N-68 (nutrient constituents)--Continued

N-68 ORTHOPHOSPHATE as PHOSPHORUS (PO₄ as P) in mg/L

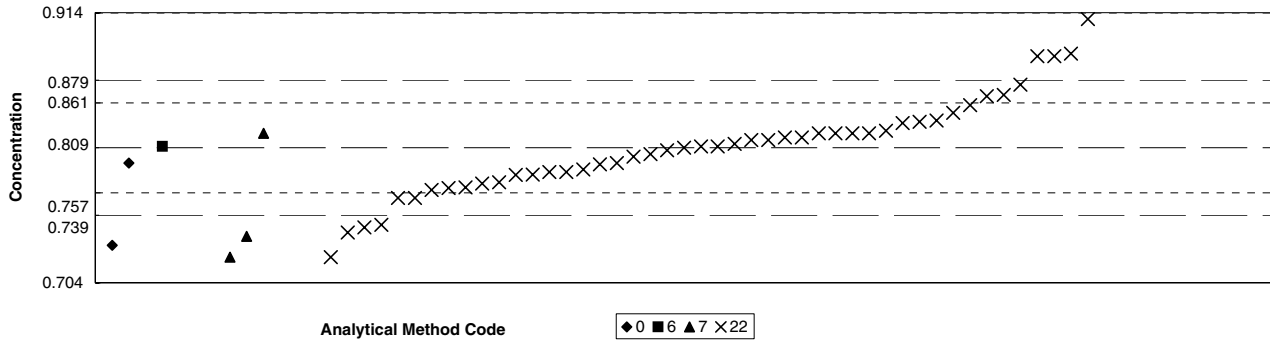

Summary	Methods				Statistics
	0	6	7	22	
N =	3	1	8	47	MPV = 0.809 mg/L
Minimum =	0.733	0.810	0.210	0.280	F-pseudosigma = 0.035
Maximum =	2.450		4.620	0.909	Rating criterion = 0.040
Median =			0.732	0.810	N = 59
F-pseudosigma =			0.176	0.030	Uh = 0.825
					Lh = 0.778

Lab	Rating	Z-value	Methods			
			0	6	7	22
1	4	0.02	--	--	--	0.810
5	1	-1.63	--	--	--	0.743
12	4	-0.17	--	--	--	0.802
13	0	-14.81	--	--	0.210	--
18	4	0.27	--	--	--	0.820
23	4	0.02	--	--	--	0.810
25	3	-0.77	--	--	--	0.778
26	0	-4.18	--	--	0.640	--
38	3	-0.52	--	--	--	0.788
42	0	-2.10	--	--	0.724	--
45	4	0.02	--	0.810	--	--
46	4	0.20	--	--	--	0.817
48	4	0.47	--	--	--	0.828
59	3	-0.69	--	--	--	0.781
64	3	0.99	--	--	--	0.849
70	3	-0.67	--	--	--	0.782
72	0	2.47	--	--	--	0.909
81	4	0.15	--	--	--	0.815
83	4	0.32	--	--	--	0.822
87	3	0.82	--	--	--	0.842
88	4	-0.42	--	--	--	0.792
89	4	0.27	--	--	--	0.820
93	4	0.27	--	--	--	0.820
96	3	-0.96	--	--	--	0.770
97	4	-0.05	--	--	--	0.807
105	4	0.27	--	--	--	0.820
107	4	0.49	--	--	--	0.829
113	4	0.15	--	--	--	0.815
118	4	-0.47	--	--	--	0.790
127	3	0.67	--	--	--	0.836
129	2	1.21	--	--	--	0.858
134	4	0.00	--	--	--	0.809
138	3	-0.82	--	--	--	0.776
140	2	1.01	--	--	--	0.850
142	3	0.52	--	--	--	0.830
154	1	-1.88	0.733	--	--	--
155	3	-0.52	--	--	--	0.788
180	0	4.62	--	--	0.996	--
183	3	-0.96	--	--	--	0.770
190	4	0.07	--	--	--	0.812
203	2	-1.48	--	--	--	0.749
204	1	1.80	--	--	--	0.882
208	0	-2.69	--	--	0.700	--
212	4	-0.30	--	--	--	0.797
213	4	-0.47	--	--	--	0.790
215	0	-13.08	--	--	--	0.280
220	1	1.76	--	--	--	0.880
224	4	-0.32	--	--	--	0.796
234	1	-1.71	--	--	0.740	--
247	4	0.27	--	--	0.820	--

Lab	Rating	Z-value	0	6	7	22
287	0	94.2	--	--	4.620	--
297	4	-0.12	--	--	--	0.804
305	4	0.20	--	--	--	0.817
306	0	-2.10	--	--	--	0.724
313	1	1.76	--	--	--	0.880
314	4	-0.30	0.797	--	--	--
316	3	-0.77	--	--	--	0.778
320	1	-1.53	--	--	--	0.747
328	0	40.6	2.450	--	--	--

Table 15. Statistical summary of reported data for standard reference samples P-35 (low ionic strength constituents)

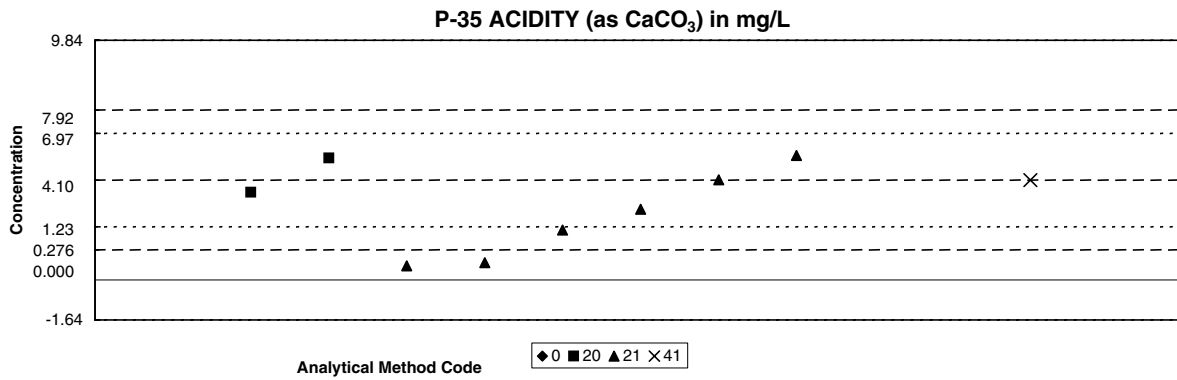

Summary	Methods				Method Codes	Statistics
	0	20	21	41		
N =	1	2	7	1	0. Other	MPV = 4.10 mg/L
Minimum =	18.86	3.60	0.58	4.10	20. Titration: colorimetric	F-pseudostigma = 1.91
Maximum =		5.00	26.00		21. Titration: electrometric	N = 11
Median =			2.90		41. Electrometric [pH and specific conductance]	Uh = 5.05
F-pseudostigma =			2.39			Lh = 2.48

Lab	Rating	Z-value	Methods			
			0	20	21	41
25	NR	--	--	--	<8	--
38	1	-1.77	--	--	0.71	--
81	2	-1.07	--	--	2.05	--
89	3	-0.63	--	--	2.90	--
105	0	11.45	--	--	26.00	--
215	4	0.47	--	5.00	--	--
220	3	0.53	--	--	5.11	--
247	4	0.00	--	--	--	4.10
273	0	7.72	18.86	--	--	--
274	4	0.01	--	--	4.11	--
328	4	-0.26	--	3.60	--	--
333	1	-1.84	--	--	0.58	--

**Table 15. Statistical summary of reported data for standard reference samples P-35 (low ionic strength constituents)--
Continued**

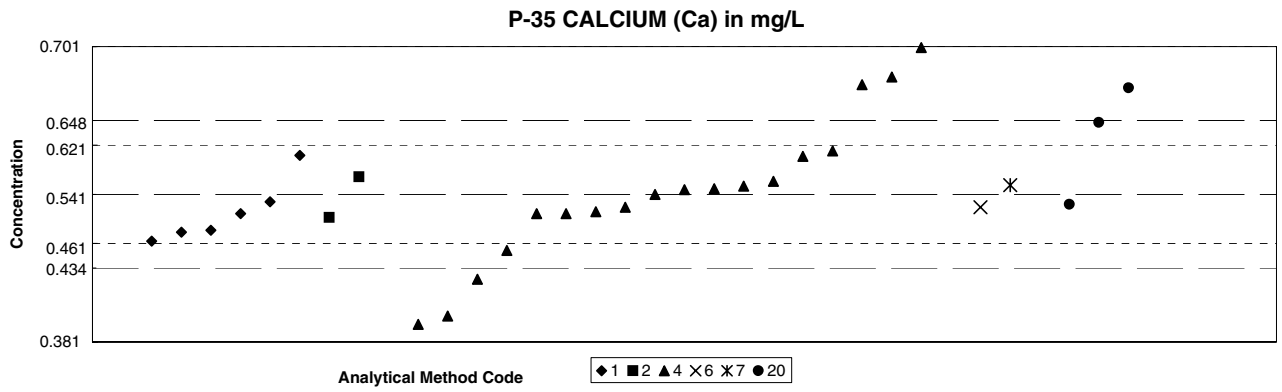

Summary	Methods						Method Codes	Statistics	
	1	2	4	6	7	20			
N =	7	2	20	1	2	5	1. Atomic absorption: direct, air	MPV =	0.541 mg/L
Minimum =	0.380	0.516	0.241	0.527	0.551	0.530	2. Atomic absorption: direct, nitrous oxide	F-pseudostigma =	0.053
Maximum =	0.583	0.560	3.100		13.000	2.400	4. Inductively coupled plasma	N =	37
Median =	0.502		0.544			0.656	6. Inductively coupled plasma/mass spectrometry	Uh =	0.588
F-pseudostigma =	0.023	0.063				0.127	7. Ion chromatography	Lh =	0.516
							20. Titration: colorimetric		

Lab	Rating	Z-value	Methods					
			1	2	4	6	7	20
1	4	0.00	--	--	0.541	--	--	--
2	4	0.19	--	--	--	--	0.551	--
23	0	34.83	--	--	--	--	--	2.400
25	0	-5.62	--	--	0.241	--	--	--
38	4	0.36	--	0.560	--	--	--	--
45	0	-3.02	0.380	--	--	--	--	--
48	4	-0.26	--	--	--	0.527	--	--
64	4	-0.39	0.520	--	--	--	--	--
81	4	0.26	--	--	0.555	--	--	--
86	1	-1.72	--	--	0.449	--	--	--
89	3	-0.73	0.502	--	--	--	--	--
93	0	2.23	--	--	0.660	--	--	--
105	0	2.38	--	--	0.668	--	--	--
110	4	-0.36	--	--	0.522	--	--	--
134	4	-0.26	--	--	0.527	--	--	--
138	4	0.09	--	--	0.546	--	--	--
140	4	-0.15	0.533	--	--	--	--	--
155	0	2.16	--	--	--	--	--	0.656
180	3	0.77	--	--	0.582	--	--	--
190	3	-0.77	0.500	--	--	--	--	--
193	4	-0.47	--	0.516	--	--	--	--
203	0	-2.64	--	--	0.400	--	--	--
215	0	47.95	--	--	3.100	--	--	--
220	0	-2.47	--	--	0.409	--	--	--
247	4	0.11	--	--	0.547	--	--	--
255	3	0.88	--	--	0.588	--	--	--
265	4	-0.39	--	--	0.520	--	--	--
268	3	0.79	0.583	--	--	--	--	--
270	0	233.43	--	--	--	--	13.000	--
273	4	-0.39	--	--	0.520	--	--	--
274	0	4.67	--	--	--	--	--	0.790
279	4	-0.21	--	--	--	--	--	0.530
287	2	1.46	--	--	--	--	--	0.619
315	2	-1.14	--	--	0.480	--	--	--
321	3	-0.96	0.490	--	--	--	--	--
328	0	2.98	--	--	0.700	--	--	--
333	4	0.17	--	--	0.550	--	--	--

Table 15. Statistical summary of reported data for standard reference samples P-35 (low ionic strength constituents)--Continued

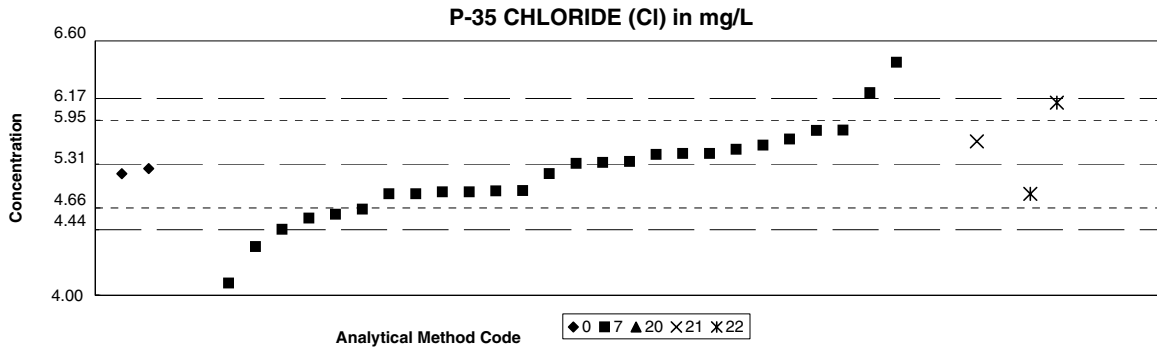

Summary	Methods					Method Codes	Statistics	
	0	7	20	21	22			
N =	4	26	2	1	3	0. Other	MPV =	5.31 mg/L
Minimum =	5.20	4.12	8.10	5.52	2.40	7. Ion chromatography	F-pseudosigma =	0.43
Maximum =	10.12	6.30	24.41			20. Titration: colorimetric	N =	36
Median =		5.25				21. Titration: electrometric	Uh =	5.58
F-pseudosigma =		0.33				22. Colorimetric	Lh =	5.00

Lab	Rating	Z-value	Methods				
			0	7	20	21	22
1	3	0.74	--	5.63	--	--	--
2	1	-1.51	--	4.65	--	--	--
23	4	0.03	--	5.32	--	--	--
25	4	-0.01	--	5.30	--	--	--
45	3	-0.66	--	5.02	--	--	--
48	3	-0.71	--	--	--	--	5.00
59	0	-2.74	--	4.12	--	--	--
64	4	0.22	--	5.40	--	--	--
81	4	0.50	--	--	--	5.52	--
86	4	0.01	--	5.31	--	--	--
89	4	0.22	--	5.40	--	--	--
93	3	0.75	--	5.63	--	--	--
105	3	-0.71	--	5.00	--	--	--
110	3	-0.63	--	5.03	--	--	--
113	4	-0.24	5.20	--	--	--	--
134	4	0.20	--	5.39	--	--	--
138	3	-0.64	--	5.03	--	--	--
140	2	1.38	--	--	--	--	5.90
180	4	0.41	--	5.48	--	--	--
183	0	11.15	10.12	--	--	--	--
190	4	-0.13	5.25	--	--	--	--
208	4	-0.24	--	5.20	--	--	--
220	0	-6.73	--	--	--	--	2.40
247	2	-1.26	--	4.76	--	--	--
256	0	2.84	6.53	--	--	--	--
265	2	-1.05	--	4.85	--	--	--
268	1	-1.91	--	4.48	--	--	--
273	3	-0.71	--	5.00	--	--	--
274	0	44.24	--	--	24.41	--	--
279	0	6.47	--	--	8.10	--	--
287	3	-0.66	--	5.02	--	--	--
301	0	2.30	--	6.30	--	--	--
315	4	0.31	--	5.44	--	--	--
321	2	-1.17	--	4.80	--	--	--
328	1	1.61	--	6.00	--	--	--
333	3	0.54	--	5.54	--	--	--

Table 15. Statistical summary of reported data for standard reference samples P-35 (low ionic strength constituents)--Continued

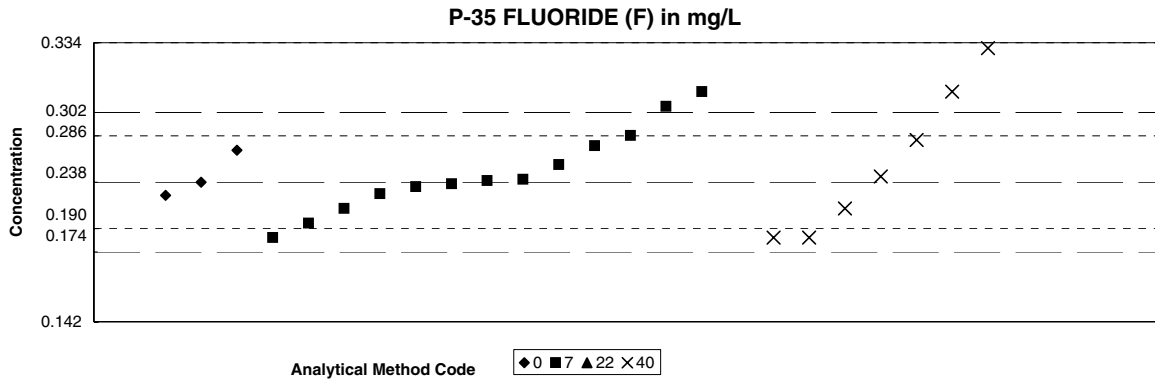

Summary	Methods				Method Codes	Statistics	
	0	7	22	40			
N =	4	13	1	7	0. Other	MPV =	0.238 mg/L
Minimum =	0.140	0.200	0.070	0.200	7. Ion chromatography	F-pseudostigma =	0.032
Maximum =	0.260	0.300		0.330	22. Colorimetric	N =	25
Median =		0.239		0.242	40. Ion selective electrode	Uh =	0.263
F-pseudostigma =		0.024		0.054		Lh =	0.220

Lab	Rating	Z-value	Methods			
			0	7	22	40
1	4	0.13	--	--	--	0.242
2	4	0.03	--	0.239	--	--
23	4	0.06	--	0.240	--	--
25	4	0.38	--	0.250	--	--
45	3	-0.88	--	0.210	--	--
59	4	-0.25	--	0.230	--	--
81	4	-0.09	--	0.235	--	--
86	3	1.00	--	0.270	--	--
89	2	-1.19	--	--	--	0.200
93	4	-0.03	--	0.237	--	--
105	3	-0.56	--	0.220	--	--
113	4	-0.28	0.229	--	--	--
134	3	-0.56	--	--	--	0.220
138	2	-1.19	--	--	--	0.200
140	3	0.91	--	--	--	0.267
180	3	0.78	--	0.263	--	--
183	3	0.69	0.260	--	--	--
190	4	0.00	0.238	--	--	--
215	1	1.95	--	--	--	0.300
247	2	-1.19	--	0.200	--	--
255	NR	--	--	--	--	<0.4
256	0	-3.07	0.140	--	--	--
273	1	1.63	--	0.290	--	--
274	0	-5.27	--	--	0.070	--
287	1	1.95	--	0.300	--	--
328	0	2.89	--	--	--	0.330

Table 15. Statistical summary of reported data for standard reference samples P-35 (low ionic strength constituents)--Continued

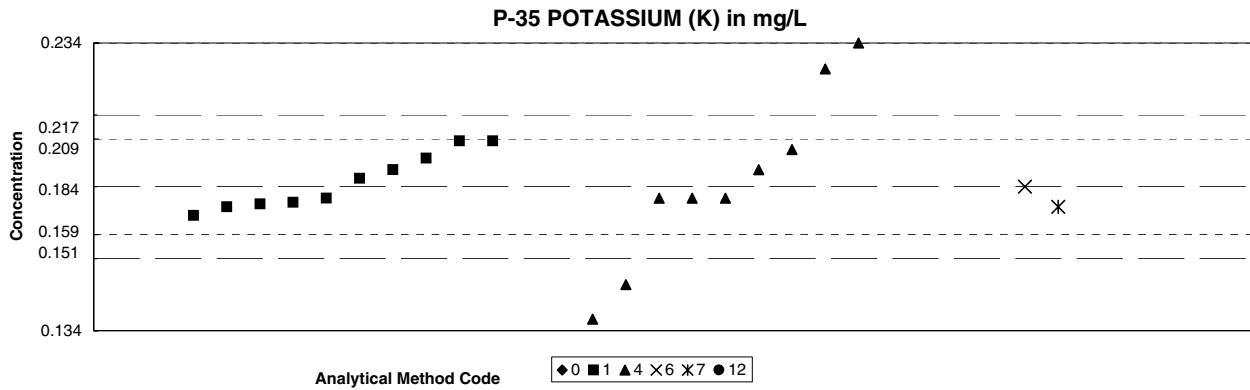

Summary	Methods						Method Codes		Statistics	
	0	1	4	6	7	12				
N =	0	11	11	1	2	2	0. Other		MPV =	0.184 mg/L
Minimum =	0.000	0.174	0.108	0.184	0.177	0.100	1. Atomic absorption: direct, air		F-pseudsigma =	0.017
Maximum =		0.242	0.250		14.660	1.210	4. Inductively coupled plasma		N =	27
Median =		0.187	0.180				6. Inductively coupled plasma/mass spectrometry		Uh =	0.200
F-pseudsigma =		0.014	0.034				7. Ion chromatography		Lh =	0.178
							12. Flame emission			

Lab	Rating	Z-value	Methods					
			0	1	4	6	7	12
1	4	-0.42	--	0.177	--	--	--	--
2	4	-0.42	--	--	--	--	0.177	--
23	NR	--	--	--	--	--	--	<0.2
25	0	2.46	--	--	0.225	--	--	--
38	4	0.36	--	0.190	--	--	--	--
45	NR	--	<1	--	--	--	--	--
48	4	0.00	--	--	--	0.184	--	--
64	4	-0.24	--	0.180	--	--	--	--
81	0	-2.76	--	--	0.138	--	--	--
89	3	0.96	--	0.200	--	--	--	--
93	4	-0.24	--	--	0.180	--	--	--
105	NR	--	--	--	<1.00	--	--	--
110	4	-0.32	--	0.179	--	--	--	--
134	3	0.60	--	0.194	--	--	--	--
138	3	0.78	--	--	0.197	--	--	--
140	4	0.18	--	0.187	--	--	--	--
180	NR	--	--	--	<0.69	--	--	--
190	3	0.96	--	0.200	--	--	--	--
193	3	-0.60	--	0.174	--	--	--	--
203	4	-0.24	--	--	0.180	--	--	--
220	0	-4.56	--	--	0.108	--	--	--
247	0	3.00	--	--	0.234	--	--	--
256	NR	--	<0.02	--	--	--	--	--
265	4	0.36	--	--	0.190	--	--	--
268	0	3.48	--	0.242	--	--	--	--
270	0	867.92	--	--	--	14.660	--	--
273	0	-2.04	--	--	0.150	--	--	--
274	0	-5.04	--	--	--	--	--	0.100
279	0	61.51	--	--	--	--	--	1.210
287	4	-0.36	--	0.178	--	--	--	--
315	0	3.96	--	--	0.250	--	--	--
328	NR	--	--	--	<2.0	--	--	--
333	4	-0.24	--	--	0.180	--	--	--

**Table 15. Statistical summary of reported data for standard reference samples P-35 (low ionic strength constituents)--
Continued**

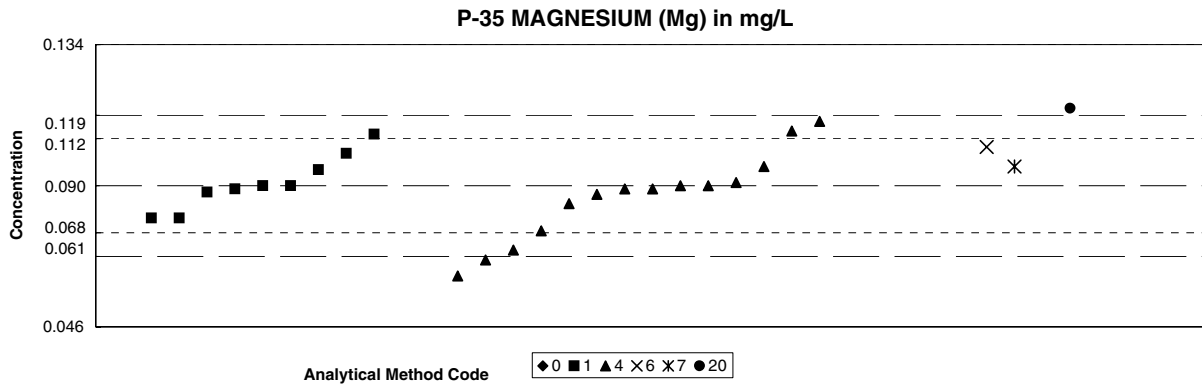

Summary	Methods						Method Codes	Statistics
	0	1	4	6	7	20		
N =	0	9	18	1	2	3	0. Other	MPV = 0.090 mg/L
Minimum =	0.000	0.080	0.019	0.102	0.096	0.114	1. Atomic absorption: direct, air	F-pseudosigma = 0.015
Maximum =		0.106	0.890		0.250	1.140	4. Inductively coupled plasma	N = 33
Median =		0.090	0.090				6. Inductively coupled plasma/mass spectrometry	Uh = 0.107
F-pseudosigma =		0.005	0.023				7. Ion chromatography	Lh = 0.087
							20. Titration: colorimetric	

Lab	Rating	Z-value	Methods					
			0	1	4	6	7	20
1	4	-0.07	--	--	0.089	--	--	--
2	4	0.41	--	--	--	--	0.096	--
23	NR	--	--	<0.2	--	--	--	--
25	0	-4.86	--	--	0.019	--	--	--
38	2	1.10	--	0.106	--	--	--	--
45	NR	--	<1	--	--	--	--	--
48	3	0.82	--	--	--	0.102	--	--
64	3	-0.68	--	0.080	--	--	--	--
81	1	-1.57	--	--	0.067	--	--	--
86	1	-1.92	--	--	0.062	--	--	--
89	4	0.00	--	0.090	--	--	--	--
93	4	0.00	--	--	0.090	--	--	--
105	4	0.41	--	--	0.096	--	--	--
110	4	-0.07	--	--	0.089	--	--	--
134	4	-0.18	--	--	0.087	--	--	--
138	4	-0.38	--	--	0.084	--	--	--
140	4	-0.07	--	0.089	--	--	--	--
155	1	1.64	--	--	--	--	--	0.114
180	2	1.16	--	--	0.107	--	--	--
190	3	-0.68	--	0.080	--	--	--	--
193	4	0.00	--	0.090	--	--	--	--
203	NR	--	--	--	<0.20	--	--	--
215	0	7.53	--	--	0.200	--	--	--
220	3	-0.96	--	--	0.076	--	--	--
247	NR	--	--	--	<0.2	--	--	--
255	4	0.07	--	--	0.091	--	--	--
265	0	54.78	--	--	0.890	--	--	--
268	4	0.34	--	0.095	--	--	--	--
270	0	10.96	--	--	--	0.250	--	--
273	2	1.37	--	--	0.110	--	--	--
274	0	26.02	--	--	--	--	--	0.470
279	0	71.90	--	--	--	--	--	1.140
287	4	-0.14	--	0.088	--	--	--	--
315	2	-1.37	--	--	0.070	--	--	--
321	3	0.68	--	0.100	--	--	--	--
328	0	7.53	--	--	0.200	--	--	--
333	4	0.00	--	--	0.090	--	--	--

Table 15. Statistical summary of reported data for standard reference samples P-35 (low ionic strength constituents)
-- Continued

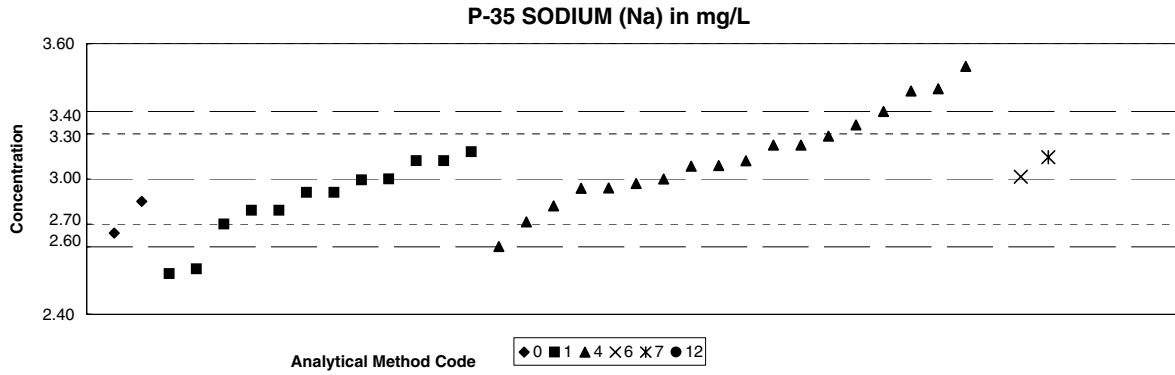

Summary	Methods						Method Codes	Statistics
	0	1	4	6	7	12		
N =	2	12	19	1	1	2	0. Other	MPV = 3.00 mg/L
Minimum =	2.76	2.58	2.70	3.01	3.10	1.45	1. Atomic absorption: direct, air	F-pseudostigma = 0.20
Maximum =	2.90	3.12	3.61			7.50	4. Inductively coupled plasma	N = 37
Median =		2.94	3.08				6. Inductively coupled plasma/mass spectrometry	Uh = 3.15
F-pseudostigma =		0.16	0.22				7. Ion chromatography	Lh = 2.88
							12. Flame emission	

Lab	Rating	Z-value	Methods					
			0	1	4	6	7	12
1	4	0.28	--	--	3.06	--	--	--
2	4	0.48	--	--	--	--	3.10	--
23	4	0.00	--	3.00	--	--	--	--
25	3	-0.60	--	--	2.88	--	--	--
38	3	-0.70	--	2.86	--	--	--	--
45	0	-2.10	--	2.58	--	--	--	--
48	4	0.05	--	--	--	3.01	--	--
64	4	-0.30	--	2.94	--	--	--	--
81	1	1.95	--	--	3.39	--	--	--
86	4	-0.10	--	--	2.98	--	--	--
89	4	-0.30	--	2.94	--	--	--	--
93	2	1.20	--	--	3.24	--	--	--
105	3	0.95	--	--	3.19	--	--	--
110	4	-0.02	--	3.00	--	--	--	--
113	4	-0.50	2.90	--	--	--	--	--
134	4	0.40	--	3.08	--	--	--	--
138	4	0.30	--	--	3.06	--	--	--
140	3	-0.70	--	2.86	--	--	--	--
180	4	0.40	--	--	3.08	--	--	--
190	4	0.40	--	3.08	--	--	--	--
193	4	-0.20	--	--	2.96	--	--	--
203	3	-0.95	--	--	2.81	--	--	--
215	2	1.50	--	--	3.30	--	--	--
220	4	-0.20	--	--	2.96	--	--	--
247	3	0.75	--	--	3.15	--	--	--
256	2	-1.20	2.76	--	--	--	--	--
265	4	0.00	--	--	3.00	--	--	--
268	1	-2.00	--	2.60	--	--	--	--
270	0	3.05	--	--	3.61	--	--	--
273	2	-1.50	--	--	2.70	--	--	--
274	0	22.48	--	--	--	--	7.50	--
279	0	-7.74	--	--	--	--	1.45	--
287	3	0.60	--	3.12	--	--	--	--
315	1	2.00	--	--	3.40	--	--	--
321	3	-1.00	--	2.80	--	--	--	--
328	0	2.50	--	--	3.50	--	--	--
333	3	0.75	--	--	3.15	--	--	--

Table 15. Statistical summary of reported data for standard reference samples P-35 (low ionic strength constituents) -- Continued

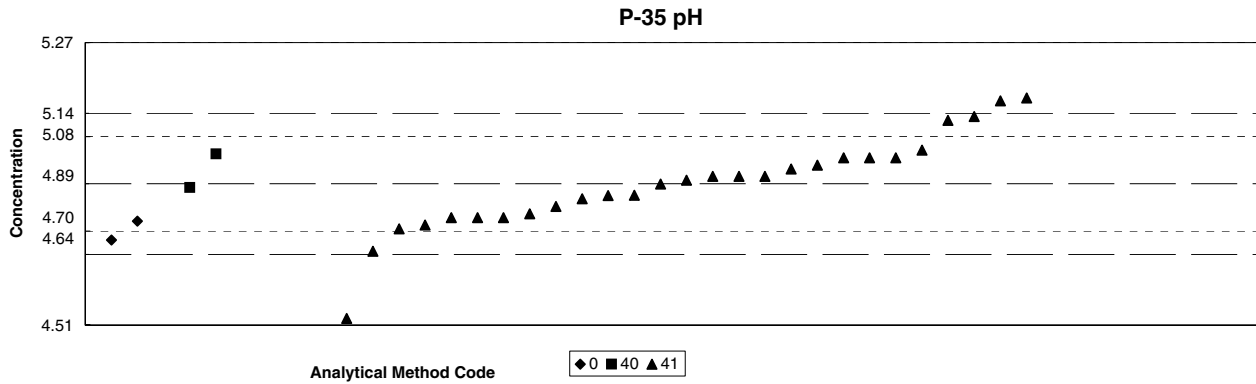

Summary	Methods			Method Codes	Statistics	
	0	40	41			
N =	3	2	34	0. Other	MPV =	4.89
Minimum =	4.74	4.88	3.66	40. Ion selective electrode	F-pseudostigma =	0.13
Maximum =	5.27	4.97	7.01	41. Electrometric [pH and specific conductance]	Rating criterion =	0.24
Median =			4.90		N =	39
F-pseudostigma =			0.12		Uh =	4.97
					Lh =	4.80

Lab	Rating	Z-value	Methods		
			0	40	41
1	0	8.11	--	--	6.87
2	3	0.91	--	--	5.11
23	4	-0.12	--	--	4.86
25	3	0.94	--	--	5.12
38	4	0.04	--	--	4.90
45	4	0.29	--	--	4.96
48	4	-0.37	--	--	4.80
59	3	-0.74	--	--	4.71
64	4	0.29	--	--	4.96
81	3	0.70	--	--	5.06
86	4	0.16	--	--	4.93
89	4	0.20	--	--	4.94
93	4	-0.04	--	4.88	--
105	4	-0.37	--	--	4.80
107	4	-0.45	--	--	4.78
110	4	0.29	--	--	4.96
113	4	-0.41	4.79	--	--
134	4	-0.13	--	--	4.86
138	0	-2.04	--	--	4.39
140	0	8.67	--	--	7.01
155	4	-0.33	--	--	4.81
180	4	-0.37	--	--	4.80
190	3	-0.61	4.74	--	--
203	4	-0.16	--	--	4.85
204	4	0.08	--	--	4.91
215	1	1.96	--	--	5.37
243	4	-0.25	--	--	4.83
247	4	0.37	--	--	4.98
256	1	1.55	5.27	--	--
268	4	-0.49	--	--	4.77
273	4	0.33	--	4.97	--
274	1	-1.72	--	--	4.47
277	2	-1.47	--	--	4.53
279	0	-5.03	--	--	3.66
287	0	-3.72	--	--	3.98
301	4	0.08	--	--	4.91
321	4	0.08	--	--	4.91
328	3	0.74	--	--	5.07
333	4	0.00	--	--	4.89

Table 15. Statistical summary of reported data for standard reference samples P-35 (low ionic strength constituents)--Continued

P-35 ORTHOPHOSPHATE AS PHOSPHORUS (PO₄) in mg/L

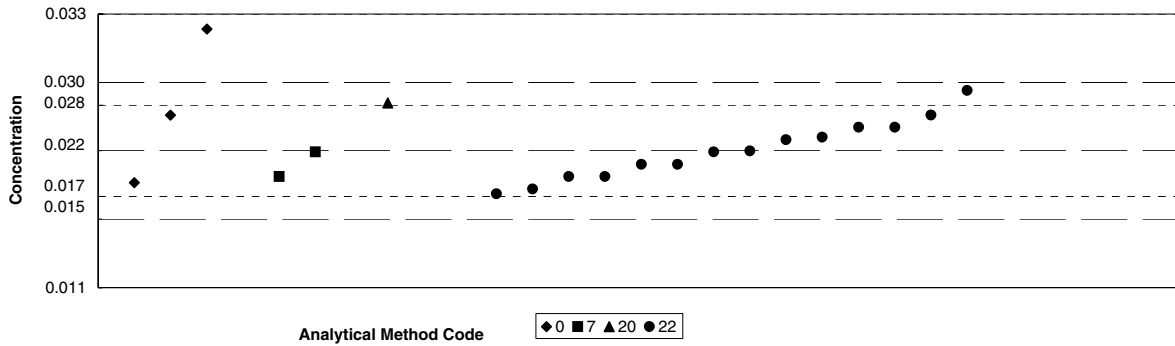

Summary	Methods				Method Codes	Statistics	
	0	7	20	22			
N =	3	2	1	19	0. Other	MPV =	0.022 mg/L
Minimum =	0.020	0.020	0.026	0.007	7. Ion chromatography	F-pseudosigma =	0.004
Maximum =	0.032	0.022		22.2	20. Titration: colorimetric	N =	25
Median =				0.022	22. Colorimetric	Uh =	0.025
F-pseudosigma =				0.003		Lh =	0.020

Lab	Rating	Z-value	Methods			
			0	7	20	22
23	3	-0.57	--	--	--	0.020
25	0	-4.07	--	--	--	0.007
38	4	-0.30	--	--	--	0.021
45	NR	--	--	<0.1	--	--
48	3	0.51	--	--	--	0.024
64	3	0.78	--	--	--	0.025
81	4	-0.03	--	0.022	--	--
89	3	-0.94	--	--	--	0.019
93	0	5984	--	--	--	22
105	3	-0.84	--	--	--	0.019
113	3	0.78	0.025	--	--	--
134	4	-0.03	--	--	--	0.022
138	4	0.00	--	--	--	0.022
140	0	-3.26	--	--	--	0.010
155	4	0.30	--	--	--	0.023
180	4	0.24	--	--	--	0.023
183	3	-0.70	0.020	--	--	--
190	4	-0.30	--	--	--	0.021
203	2	1.32	--	--	--	0.027
215	3	-0.57	--	--	--	0.020
220	3	0.51	--	--	--	0.024
247	3	-0.57	--	0.020	--	--
256	0	2.67	0.032	--	--	--
273	0	3.48	--	--	--	0.035
274	0	6.45	--	--	--	0.046
321	2	1.05	--	--	0.026	--
328	NR	--	<0.02	--	--	--

Table 15. Statistical summary of reported data for standard reference samples P-35 (low ionic strength constituents)--Continued

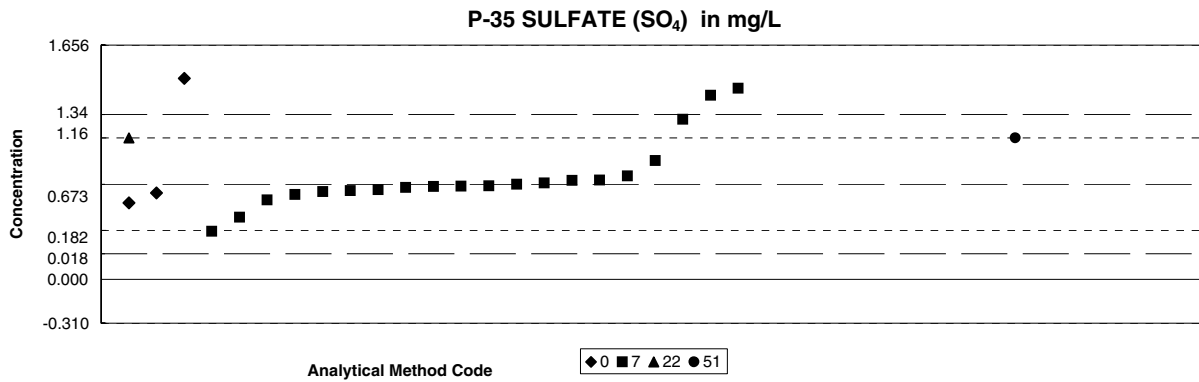

Summary	Methods				Method Codes	Statistics
	0	7	22	51		
N =	3	21	0	3	0. Other	MPV = 0.673 mg/L
Minimum =	0.540	0.340	0.000	1.000	7. Ion chromatography	F-pseudostigma = 0.328
Maximum =	1.420	1.770		1.909	22. Colorimetric	N = 27
Median =		0.661			51. Turbidimetric	Uh = 1.065
F-pseudostigma =		0.077				Lh = 0.623

Lab	Rating	Z-value	Methods			
			0	7	22	51
1	4	-0.04	--	0.661	--	--
2	4	0.09	--	0.702	--	--
23	0	2.07	--	1.350	--	--
25	NR	--	--	<5.0	--	--
45	4	0.02	--	0.680	--	--
48	NR	--	--	--	--	<1.0
59	3	-0.71	--	0.440	--	--
64	4	-0.16	--	0.620	--	--
81	NR	--	--	--	--	<5
86	2	1.39	--	1.130	--	--
89	NR	--	--	<1.0	--	--
93	4	-0.04	--	0.659	--	--
105	NR	--	--	<1.00	--	--
110	4	-0.14	--	0.626	--	--
113	4	-0.41	0.540	--	--	--
134	4	0.08	--	0.700	--	--
138	4	0.00	--	0.673	--	--
140	3	1.00	--	--	--	1.00
180	4	-0.05	--	0.655	--	--
190	4	-0.19	0.610	--	--	--
203	NR	--	--	--	--	<2.5
208	NR	--	--	<2.0	--	--
220	0	3.77	--	--	--	1.909
247	NR	--	--	<1.0	--	--
255	NR	--	--	--	--	<15
256	0	2.28	1.420	--	--	--
265	4	-0.34	--	0.560	--	--
268	4	-0.12	--	0.633	--	--
270	2	-1.02	--	0.340	--	--
273	4	-0.22	--	0.600	--	--
274	0	3.62	--	--	--	1.860
287	0	3.35	--	1.770	--	--
315	4	0.17	--	0.730	--	--
321	4	0.51	--	0.840	--	--
328	1	1.91	--	1.300	--	--
333	4	-0.07	--	0.650	--	--

Table 15. Statistical summary of reported data for standard reference samples P-35 (low ionic strength constituents)--Continued

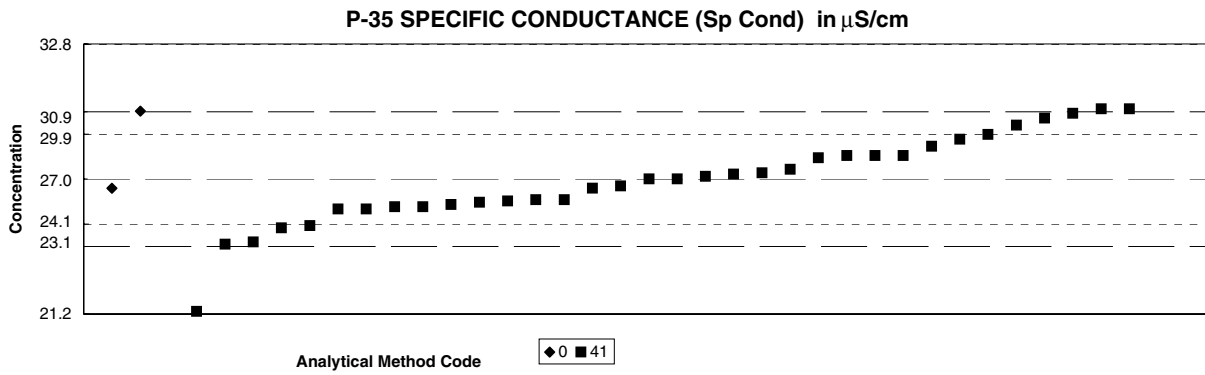

Summary	Methods		Statistics
	0	41	
N =	2	36	MPV = 27.0 $\mu\text{S}/\text{cm}$ F-pseudostigma = 1.9 N = 38 Uh = 28.4 Lh = 25.8
Minimum =	26.6	15.3	
Maximum =	29.9	442	
Median =		27.0	
F-pseudostigma =		1.8	
	Method Codes		
	0. Other		
	41. Electrometric [pH and specific conductance]		

Lab	Rating	Z-value	Methods	
			0	41
1	3	-0.67	--	25.7
2	2	1.50	29.9	--
23	4	0.10	--	27.2
25	1	1.56	--	30.0
45	3	-0.67	--	25.7
48	2	-1.40	--	24.3
59	4	-0.16	--	26.7
64	2	1.19	--	29.3
81	3	-0.57	--	25.9
86	3	0.88	--	28.7
89	0	215	--	442
93	0	-2.95	--	21.3
105	3	-0.62	--	25.8
107	3	0.52	--	28.0
110	4	-0.49	--	26.1
113	4	-0.21	26.6	--
134	4	0.13	--	27.3
138	3	0.52	--	28.0
140	2	1.45	--	29.8
155	3	-0.62	--	25.8
180	4	0.00	--	27.0
190	4	-0.47	--	26.1
193	4	0.00	--	27.0
203	3	0.52	--	28.0
204	3	-0.52	--	26.0
215	2	-1.09	--	24.9
243	4	0.47	--	27.9
247	4	0.21	--	27.4
268	3	0.73	--	28.4
273	2	1.35	--	29.6
274	4	0.05	--	27.1
277	2	-1.04	--	25.0
279	4	-0.21	--	26.6
287	4	-0.47	--	26.1
301	0	-6.07	--	15.3
321	2	-1.45	--	24.2
328	1	1.56	--	30.0
333	3	0.99	--	28.9

Table 16. Statistical summary of reported data for standard reference samples HG-31 (mercury)

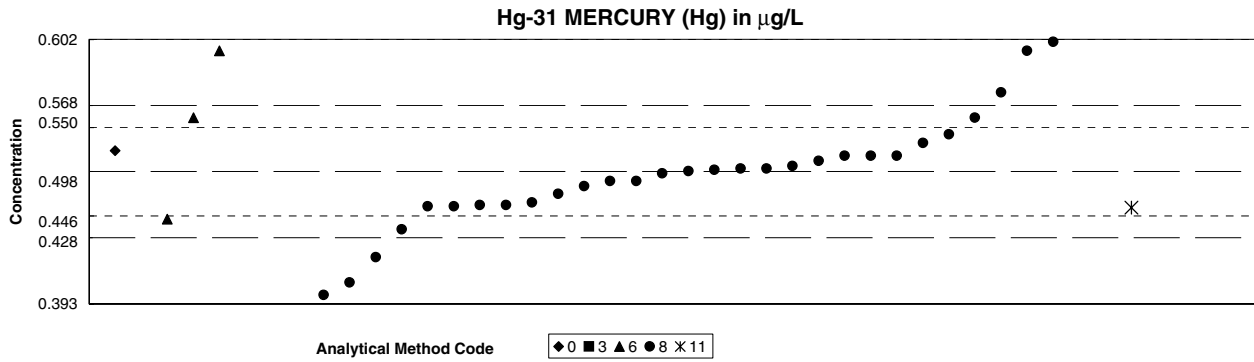

Summary	Methods					Method Codes	Statistics
	0	3	6	8	11		
N =	1	1	3	33	1	0. Other	MPV = 0.498 µg/L
Minimum =	0.514	44.000	0.460	0.000	0.469	3. Atomic absorption: graphite furnace	F-pseudosigma = 0.035
Maximum =			0.593	0.620		6. Inductively coupled plasma/mass spectrometry	N = 39
Median =				0.496		8. Atomic absorption: cold vapor	Uh = 0.517
F-pseudosigma =				0.030		11. Atomic absorption: hydride	Lh = 0.470

Lab	Rating	Z-value	Methods				
			0	3	6	8	11
1	4	0.03	--	--	--	0.499	--
10	4	0.06	--	--	--	0.500	--
12	0	-6.26	--	--	--	0.280	--
13	1	-1.95	--	--	--	0.430	--
18	0	2.73	--	--	0.593	--	--
45	4	0.34	--	--	--	0.510	--
48	0	-2.81	--	--	--	0.400	--
50	3	-0.77	--	--	--	0.471	--
55	4	0.06	--	--	--	0.500	--
59	3	-0.80	--	--	--	0.470	--
69	NR	--	--	--	--	<0.50	--
81	4	-0.34	--	--	--	0.486	--
87	0	-14.28	--	--	--	0.000	--
89	4	-0.23	--	--	--	0.490	--
96	0	2.73	--	--	--	0.593	--
97	3	-0.52	--	--	--	0.480	--
105	3	0.83	--	--	--	0.527	--
107	2	1.21	--	--	0.540	--	--
118	0	-3.10	--	--	--	0.390	--
127	4	-0.06	--	--	--	0.496	--
134	4	0.11	--	--	--	0.502	--
138	3	-0.77	--	--	--	0.471	--
142	3	-0.80	--	--	--	0.470	--
144	3	0.63	--	--	--	0.520	--
147	2	-1.32	--	--	--	0.452	--
198	3	-0.72	--	--	--	0.473	--
203	4	0.34	--	--	--	0.510	--
212	2	1.21	--	--	--	0.540	--
213	0	2.93	--	--	--	0.600	--
215	1	1.78	--	--	--	0.560	--
220	0	-2.53	--	--	--	0.410	--
234	4	0.23	--	--	--	0.506	--
247	4	-0.23	--	--	--	0.490	--
265	2	-1.09	--	--	0.460	--	--
277	4	0.34	--	--	--	0.510	--
298	4	0.46	0.514	--	--	--	--
304	4	0.00	--	--	--	0.498	--
307	3	-0.83	--	--	--	--	0.469
321	0	1248.60	--	44.000	--	--	--
328	0	3.50	--	--	--	0.620	--

Table 17. Most probable values for constituents and properties in standard reference samples distributed in October 2000

[MPV, most probable value; µg/L, microgram per liter; n, number of samples; mg/L, milligram per liter; µS/cm, microsiemens per centimeter at 25 degrees Celsius.]

T-163	Analyte = Silver	Aluminum	Arsenic	Boron	Barium
	MPV = 16.9 µg/L	16.8 µg/L	25.3 µg/L	10.6 µg/L	7.40 µg/L
	n = 54	32	55	16	44
	F-pseudosigma = 1.47	1.67	1.78	2.39	0.537
	Analyte = Beryllium	Calcium	Cadmium	Cobalt	Chromium
	MPV = 22.0 µg/L	6.30 mg/L	6.59 µg/L	12.0 µg/L	40.1 µg/L
n = 42	64	60	37	58	
F-pseudosigma = 1.04	0.259	0.419	0.371	2.15	
Analyte = Copper	Iron	Potassium	Lithium	Magnesium	
MPV = 35.8 µg/L	60.0 µg/L	1.02 mg/L	1.60 µg/L	1.23 mg/L	
n = 63	61	53	13	59	
F-pseudosigma = 1.74	5.93	0.137	0.993	0.074	
Analyte = Manganese	Molybdenum	Sodium	Nickel	Lead	
MPV = 15.8 µg/L	12.6 µg/L	39.6 mg/L	15.4 µg/L	32.0 µg/L	
n = 57	28	59	55	60	
F-pseudosigma = 1.11	0.926	1.89	1.26	2.17	
Analyte = Antimony	Selenium	Silica	Strontium	Thallium	
MPV = 32.5 µg/L	8.88 µg/L	4.56 mg/L	35.5 µg/L	39.9 µg/L	
n = 36	46	37	32	36	
F-pseudosigma = 1.89	1.11	0.188	1.78	3.00	
Analyte = Uranium	Vanadium	Zinc			
MPV = 4.60 µg/L	35.0 µg/L	18.5 µg/L			
n = 8	35.0	62.0			
F-pseudosigma = 0.156	1.80	1.30			
M-156	Analyte = Alkalinity	Boron	Calcium	Chloride	Residue on Evaporation
	MPV = 61.8 mg/L	78.6 µg/L	30.2 mg/L	64.7 mg/L	244 mg/L
	n = 70	26	74	80	49
	F-pseudosigma = 2.52	5.11	1.13	1.87	13.4
	Analyte = Fluoride	Potassium	Magnesium	Sodium	Phosphorus
	MPV = 0.523 mg/L	2.13 mg/L	6.92 mg/L	44.6 mg/L	0.578 mg/L
	n = 57	64	74	72	55
	F-pseudosigma = 0.045	0.163	0.32	2.30	0.039
	Analyte = pH	Silica	Sulfate	Specific conductance	Strontium
	MPV = 7.95	4.73 mg/L	43.0 mg/L	440 mS/cm	239 µg/L
n = 75	51	78	70	30	
F-pseudosigma = 0.203	0.308	1.78	14.8	9.64	
Analyte = Vanadium					
MPV = 9.53 mg/L					
n = 24					
F-pseudosigma = 1.77					
N-67	Analyte = Ammonia as N	Ammonia + Organic N as N	Nitrate as N	Total Phosphorus	Orthophosphate as P
	MPV = 0.433 mg/L	0.450 mg/L	0.222 mg/L	0.279 mg/L	0.274 mg/L
	n = 63	45	65	61	61
	F-pseudosigma = 0.030	0.059	0.009	0.010	0.013
N-68	Analyte = Ammonia as N	Ammonia + Organic N as N	Nitrate as N	Total Phosphorus	Orthophosphate as P
	MPV = 0.480 mg/L	0.650 mg/L	1.68 mg/L	0.830 mg/L	0.809 mg/L
	n = 56	43	65	57	59
	F-pseudosigma = 0.048	0.103	0.076	0.030	0.035

Table 17. Most probable values for constituents and properties in standard reference samples distributed in October 2000 – continued

[MPV, most probable value; µg/L, microgram per liter; n, number of samples; mg/L, milligram per liter; µS/cm, microsiemens per centimeter at 25 degrees Celsius.]

P-35

Analyte =	Acidity	Calcium	Chloride	Fluoride	Potassium
MPV =	4.10 mg/L	0.541 mg/L	5.31 mg/L	0.238 mg/L	0.184 mg/L
n =	11	37	36	25	27
F-pseudostandard =	1.91	0.053	0.432	0.032	0.017
Analyte =	Magnesium	Sodium	pH	Orthophosphate	Sulfate
MPV =	0.090 mg/L	3.00 mg/L	4.89	0.022 mg/L	0.673 mg/L
n =	33	37	39	25	27
F-pseudostandard =	0.015	0.200	0.126	0.004	0.328
Analyte =	Specific conductance				
MPV =	27 µS/cm				
n =	38				
F-pseudostandard =	1.93				

Hg-31

Analyte =	Mercury
MPV =	0.498 mg/L
n =	39
F-pseudostandard =	0.035

Table 18. Laboratory performance in percent acceptable analyses and names of unacceptable analytes

Laboratory Number	Number Analytes Reported of 66	Percent Acceptable	Unacceptable Analytes T-163	Unacceptable Analytes M-156	Unacceptable Analytes N-67	Unacceptable Analytes N-68	Unacceptable Analytes P-35	Unacceptable Analytes Hg-31
1	63	97%		pH			pH	
2	9	89%					Chloride	
5	10	60%			Ammonia Orthophosphate	Ammonia Orthophosphate		
10	22	95%	Manganese					
12	33	79%	Silver Arsenic Cadmium Chromium		Ammonia Ammonia			Mercury
13	46	81%	Barium Copper	Residue on Evaporation Phosphorus	Ammonia Orthophosphate	Orthophosphate		Mercury
18	36	72%	Copper Antimony	Residue on Evaporation Sulfate	Ammonia Ammonia Nitrate	Ammonia Ammonia + Organic N		Mercury
21	6	100%						
23	54	79%	Barium Antimony	Calcium Residue on Evaporation Sodium Phosphorus Sulfate	Ammonia Phosphorus		Calcium Sulfate	
24	27	100%						
25	63	55%	Arsenic Barium Calcium Cobalt Chromium Copper Lithium Magnesium Manganese Nickel Lead Silica Strontium Zinc	Boron Residue on Evaporation Strontium	Ammonia Phosphorus	Ammonia + Organic N	Calcium Potassium Magnesium Orthophosphate Specific conductance	
26	2	0%				Nitrate Orthophosphate		
31	5	100%						
32	26	96%	Silica					
38	25	88%		Magnesium		Ammonia	Acidity	
42	48	85%	Silica	Fluoride Silica	Phosphorus Orthophosphate	Phosphorus Orthophosphate		
45	41	76%	Iron Potassium Magnesium Nickel	Potassium Magnesium	Phosphorus		Calcium Sodium	
46	10	80%			Nitrate Orthophosphate			
48	57	86%	Aluminum Iron	Chloride Phosphorus Sulfate	Ammonia Nitrate			Mercury
50	41	100%						
51	10	90%			Nitrate			
55	7	100%						

Table 18. Laboratory performance in percent acceptable analyses and names of unacceptable analytes -- Continued

Laboratory Number	Number Analytes Reported of 66	Percent Acceptable	Unacceptable Analytes T-163	Unacceptable Analytes M-156	Unacceptable Analytes N-67	Unacceptable Analytes N-68	Unacceptable Analytes P-35	Unacceptable Analytes Hg-31
57	43	72%	Aluminum Chromium Potassium Molybdenum Sodium Selenium Zinc	Boron Chloride Potassium Sulfate Specific conductance				
59	47	89%	Silver Sodium Antimony	pH			Chloride	
64	30	90%		Phosphorus	Ammonia			
69	32	88%	Calcium Antimony	Magnesium				
70	43	81%	Beryllium Iron	Residue on Evaporation Phosphorus Sulfate	Ammonia Phosphorus	Ammonia		
72	10	30%			Ammonia Nitrate Phosphorus Orthophosphate	Ammonia Nitrate Orthophosphate		
76	18	100%						
81	60	78%	Silver Barium Beryllium Cobalt Chromium Iron Molybdenum Nickel Lead			Ammonia + Organic N	Potassium Magnesium Sodium	
83	8	100%						
84	2	100%						
86	47	79%	Arsenic Cadmium Cobalt Thallium	Sulfate	Ammonia Nitrate	Nitrate	Calcium Magnesium	
87	41	68%	Barium Calcium Cadmium Potassium Molybdenum Nickel Selenium	Calcium Magnesium Specific conductance	Nitrate	Ammonia		Mercury
88	6	17%			Ammonia Nitrate Orthophosphate	Ammonia Nitrate		
89	59	77%	Aluminum Calcium Cobalt Chromium Manganese Lead Antimony Selenium Thallium Vanadium	Magnesium Specific conductance			Specific conductance	
90	6	83%				Ammonia + Organic N		
93	29	76%		Sodium	Phosphorus Orthophosphate	Nitrate	Calcium Orthophosphate Specific conductance	
96	34	97%						Mercury

Table 18. Laboratory performance in percent acceptable analyses and names of unacceptable analytes -- Continued

Laboratory Number	Number Analytes Reported of 66	Percent Acceptable	Unacceptable Analytes T-163	Unacceptable Analytes M-156	Unacceptable Analytes N-67	Unacceptable Analytes N-68	Unacceptable Analytes P-35	Unacceptable Analytes Hg-31
97	33	85%	Beryllium Cadmium Molybdenum Vanadium		Ammonia			
105	65	91%		Calcium Residue on Evaporation		Phosphorus	Acidity Calcium	
107	27	85%	Calcium Copper	Chloride		Ammonia		
109	19	84%	Magnesium	Chloride Sulfate				
110	14	100%						
113	51	98%		Residue on Evaporation				
114	10	100%						
118	30	53%	Arsenic Cadmium Copper Iron Silica Zinc	Silica Specific	Ammonia Ammonia Nitrate Phosphorus Orthophosphate			Mercury
121	22	77%	Cobalt Chromium Copper Molybdenum Strontium					
127	55	86%	Silver Copper Magnesium Molybdenum	Silica Specific conductance	Nitrate			
129	22	86%			Ammonia	Ammonia + Organic N Phosphorus		
131	4	50%		Fluoride Phosphorus				
134	65	97%	Uranium			Ammonia		
138	62	97%	Nickel				pH	
140	47	74%	Silver Barium Calcium Chromium Zinc	pH	Ammonia Ammonia	Ammonia Ammonia + Organic N	pH Orthophosphate	
142	54	80%	Calcium Magnesium Sodium Antimony	Calcium Sodium Phosphorus Silica	Nitrate	Ammonia		
144	11	64%	Arsenic Beryllium Copper Nickel					
147	8	100%						
151	1	100%						
154	47	83%	Cadmium Magnesium Sodium Thallium Zinc	Specific conductance	Orthophosphate	Orthophosphate		
155	22	77%		Magnesium	Nitrate	Nitrate	Calcium Magnesium	

Table 18. Laboratory performance in percent acceptable analyses and names of unacceptable analytes -- Continued

Laboratory Number	Number Analytes Reported of 66	Percent Acceptable	Unacceptable Analytes T-163	Unacceptable Analytes M-156	Unacceptable Analytes N-67	Unacceptable Analytes N-68	Unacceptable Analytes P-35	Unacceptable Analytes Hg-31
180	55	47%	Boron Barium Calcium Copper Potassium Magnesium Sodium Zinc	Calcium Chloride Fluoride Potassium Magnesium Sodium Phosphorus pH Sulfate Specific conductance Vanadium		Orthophosphate		
183	10	80%		Fluoride			Chloride	
190	45	87%	Silver Silica	Calcium Potassium Silica		Nitrate		
193	36	89%	Antimony Zinc			Ammonia Ammonia + Organic N		
198	24	88%	Calcium Copper Sodium					
203	47	86%	Barium Manganese	Magnesium	Ammonia	Nitrate	Calcium	
204	31	87%	Silver Lead Thallium			Orthophosphate		
208	6	60%		Chloride		Orthophosphate		
209	2	100%						
212	54	81%	Aluminum Iron Molybdenum Antimony Silica	Phosphorus Silica	Phosphorus	Ammonia Phosphorus		
213	13	80%				Ammonia + Organic N		Mercury
215	46	41%	Arsenic Calcium Copper Iron Magnesium Manganese Nickel Lead Thallium	Calcium Magnesium Sulfate Vanadium	Ammonia Ammonia Nitrate Phosphorus Orthophosphate	Ammonia + Organic N Nitrate Phosphorus Orthophosphate	Calcium Fluoride Magnesium pH	Mercury
220	36	75%	Lead	Sulfate	Nitrate	Orthophosphate	Calcium Chloride Potassium Sulfate	Mercury
224	10	80%			Ammonia Ammonia			
230	10	60%		Fluoride Potassium Magnesium Specific conductance				
234	51	92%	Thallium	Boron Phosphorus		Orthophosphate		
235	31	97%		Magnesium				
243	10	100%						
247	65	76%	Arsenic Boron Beryllium Manganese Silica Zinc	Alkalinity Residue on Evaporation Fluoride	Ammonia Ammonia Nitrate	Ammonia + Organic N Nitrate	Potassium	
254	21	95%	Cobalt					
255	23	100%						

Table 18. Laboratory performance in percent acceptable analyses and names of unacceptable analytes -- Continued

Laboratory Number	Number Analytes Reported of 66	Percent Acceptable	Unacceptable Analytes T-163	Unacceptable Analytes M-156	Unacceptable Analytes N-67	Unacceptable Analytes N-68	Unacceptable Analytes P-35	Unacceptable Analytes Hg-31
256	33	53%	Silver Aluminum Arsenic Beryllium Cobalt Strontium Zinc	Magnesium Sodium Silica			Chloride Fluoride pH Orthophosphate Sulfate	
257	22	75%	Arsenic Cadmium Lead Selenium Zinc					
258	12	42%		Boron Calcium Chloride Fluoride Potassium Magnesium Sodium				
259	15	93%		Potassium				
261	12	17%	Calcium Iron Magnesium Zinc	Calcium Chloride Potassium Magnesium Sulfate Specific conductance				
263	10	90%		Silica				
265	46	96%		Boron			Magnesium	
266	11	100%						
267	7	100%						
268	21	71%	Calcium	Calcium Potassium			Chloride Potassium Sodium	
270	29	31%	Silver Calcium Cobalt Chromium Copper Iron Lithium Nickel Thallium Zinc	Calcium Fluoride Potassium Magnesium Phosphorus Sulfate			Calcium Potassium Magnesium Sodium	
273	46	70%	Boron Copper Lithium Nickel Lead Zinc	Alkalinity Boron Fluoride Strontium			Acidity Fluoride Potassium Orthophosphate	
274	34	35%	Calcium Copper Magnesium Manganese Sodium Lead Silica Zinc	Alkalinity Chloride Magnesium Sodium Silica			Calcium Chloride Fluoride Potassium Magnesium Sodium pH Orthophosphate Sulfate	
275	9	44%		Alkalinity Chloride Potassium Magnesium Sodium				
276	8	63%		Chloride Sodium Sulfate				
277	28	75%	Silver Copper Potassium Manganese Sodium	Alkalinity Potassium				

Table 18. Laboratory performance in percent acceptable analyses and names of unacceptable analytes -- Continued

Laboratory Number	Number Analytes Reported of 66	Percent Acceptable	Unacceptable Analytes T-163	Unacceptable Analytes M-156	Unacceptable Analytes N-67	Unacceptable Analytes N-68	Unacceptable Analytes P-35	Unacceptable Analytes Hg-31
279	18	33%	Potassium Magnesium Sodium	Calcium Potassium Magnesium Sodium			Chloride Potassium Magnesium Sodium pH	
280	5	80%		Magnesium				
287	35	69%	Aluminum Manganese Zinc		Ammonia Nitrate Orthophosphate	Ammonia Orthophosphate	Fluoride pH Sulfate	
291	1	0%				Nitrate		
297	44	74%	Calcium Potassium Sodium Nickel Silica	Alkalinity Calcium Potassium Magnesium Silica	Nitrate			
298	1	100%						
301	3	33%					Chloride Specific conductance	
304	20	95%		Chloride				
305	37	80%	Arsenic Potassium Sodium Lead	Potassium Sodium	Nitrate			
306	23	45%	Copper Potassium Sodium Nickel	Potassium Sodium Phosphorus	Ammonia Phosphorus	Nitrate Phosphorus Orthophosphate		
307	24	58%	Silver Arsenic Cadmium Copper Iron Manganese Lead Zinc	Sulfate	Orthophosphate			
309	19	42%	Barium Calcium Potassium Sodium Silica Strontium	Calcium Chloride Potassium Silica Sulfate				
313	10	90%				Orthophosphate		
314	5	100%						
315	18	67%	Iron Manganese	Chloride Potassium			Potassium Sodium	
316	10	80%			Phosphorus	Phosphorus		
318	5	100%						
320	10	70%			Ammonia	Ammonia + Organic N Orthophosphate		
321	13	77%			Ammonia Phosphorus			Mercury
323	19	89%		Boron Specific conductance				
324	11	9%	Aluminum Calcium Iron Manganese Zinc	Alkalinity Calcium Residue on Evaporation Sulfate Specific conductance				

Table 18. Laboratory performance in percent acceptable analyses and names of unacceptable analytes -- Continued

Laboratory Number	Number Analytes Reported of 66	Percent Acceptable	Unacceptable Analytes T-163	Unacceptable Analytes M-156	Unacceptable Analytes N-67	Unacceptable Analytes N-68	Unacceptable Analytes P-35	Unacceptable Analytes Hg-31
328	66	48%	Boron Calcium Cobalt Chromium Potassium Manganese Sodium Nickel Lead Strontium Uranium Vanadium Zinc	Boron Fluoride Silica Sulfate Strontium Vanadium	Ammonia Phosphorus Orthophosphate	Orthophosphate	Calcium Chloride Fluoride Magnesium Sodium Sulfate Specific conductance	Mercury
331	43	62%	Silver Aluminum Arsenic Calcium Potassium Magnesium Molybdenum Sodium Zinc	Calcium Potassium Magnesium Silica Specific conductance Strontium				
333	16	94%					Acidity	
334	13	69%	Arsenic Iron	Alkalinity Sulfate				